



Scanning - Shortwave - Ham Radio - Equipment
Internet Streaming - Computers - Antique Radio

Monitoring Times

A Publication of Grove Enterprises

Volume 31, No. 10
October 2012
U.S. \$6.95
Can. \$6.95
Printed in the
United States

Shortwave DX with a Crystal Set

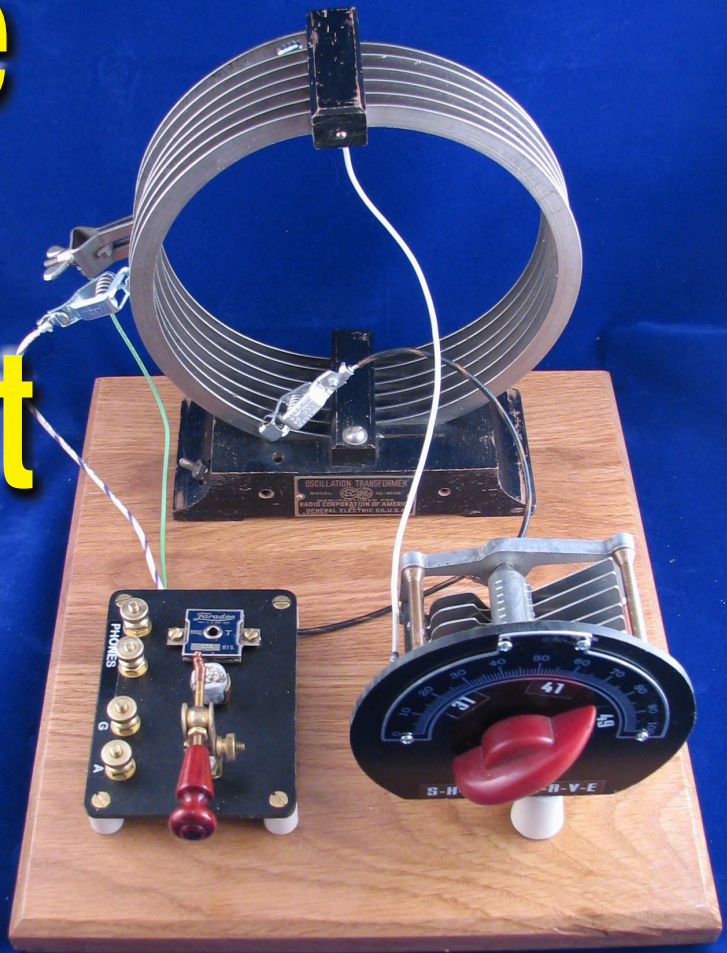

In this issue:

- MT Travels to Radio Free Asia
- The State of Shortwave Radio Today
- Antennas for the Shortwave Listener
- NewStar DR111 Digital Shortwave Radio



GROVE

Your Source for Radio Scanners, Receivers, Accessories, and Publications

AOR

AR-8600II	RCV11	\$989.95
AOR SR2000A (B)	RCV36	\$3,199.95
AR2300B	RCV60	\$3,809.95
AR5001D (B)	RCV68	\$4,499.95
AOR AR-ALPHA	RCV01	\$CALL

KAITO

KA801	RCV61	\$79.95
KA1103	RCV55	\$89.95
KA1121	RCV37	\$149.95

SANGEAN

ATS-909X (Black)	RCV67-BK	\$259.95
ATS-505P	RCV7	\$109.95
ATS-909X	RCV67	\$259.95
WFR-20	RCV40	\$239.95
WFR-1	RCV56	\$279.95

GRUNDIG

S450DLX Field Radio	RCV70	\$99.95
G3	RCV65	\$99.95
Satellit 750	RCV58	\$299.95

ICOM

R75	RCV32	\$719.95
R2500	RCV52	\$929.95
IC-R9500	RCV27	\$CALL

PERSEUS

RCV57	\$1199.00
-------	-----------

BONITO

RadioJet 1102S	RCV71	\$699.95
----------------	-------	----------

WiNRADiO

WR-G33EM	RCV16	\$949.95
WR-G33EM/GPS	RCV16/GPS	\$999.95
WR-G33WSM	RCV28	\$949.95
WR-G313 (Internal)	RCV31	\$1149.95
WR-G313 (External)	RCV31-E	\$1149.95
WR-G313i/180	RCV31/MOD04	\$1,399.90
WR-G313e/180	RCV31E/MOD04	\$1,399.90
WR-G305e/WFM/PD	RCV63P/MOD09	\$899.95
WR-G305i	RCV53	\$699.95
WR-G305i w/pro demodulator	RCV53P	\$799.95
WR-G305e	RCV63	\$699.95
WR-G305e w/pro demodulator	RCV63P	\$799.95
WR-G315 (Internal)	RCV54	\$CALL
WR-G315 (External)	RCV64	\$CALL
WR-G31DDC Excalibur	RCV66	\$899.95
WR-G33DDC Excalibur Pro	RCV62	\$CALL
G39DDCi Excelsior (Internal)	RCV69	\$CALL
G39DDCe Excelsior (External)	RCV69E	\$CALL
WR-G39WSBe SONOBUOY	RCV39E	\$CALL
WR-G39WSBi SONOBUOY	RCV39I	\$CALL

Grove means service. You won't find better customer service anywhere. BUY TODAY!

Established in 1979 by well-known communications expert Bob Grove, Grove Enterprises has become a world leader in radio monitoring equipment, accessories, and publications.

If you decide you don't like a product, Grove Enterprises doesn't penalize you for it. There is NO restocking fee so long as you call our toll free number for a return authorization within fifteen days of shipment and the item is returned in new condition. Once the item is received we will give you credit toward another item or issue a full refund (less shipping charges). Software cannot be returned if opened.

That's it! No hassle! No negotiations! Just call 1-800-438-8155 and our friendly staff will assist you with a return authorization number.

WiNRADiO Accessories

USB Adaptor	ACC 2	\$19.95
PCMCIA PC Card	ACC 28	\$64.95
WR-BT-3500 VHF/UHF Power Injector (BIAS T)	ACC29	\$99.95
Client Server Option-G313 Series	ACC14D	\$99.95
Mounting Clamps for AX-71C	ACC71	\$18.95
WR-LWA-0130 long-wire antenna adaptor	ADP35	\$39.95
AX-71C discone antenna	ANT01	\$89.95
AX-37A wide-band log-periodic antenna	ANT28	\$389.95
AX-37AM wide-band log-periodic antenna	ANT29	\$499.95
AX-07B flexible VHF/UHF antenna	ANT47	\$27.95
AX-91M magnetic antenna base	ANT48	\$27.95
AX-81S active HF antenna	ANT51	\$189.95
WR-AX-31C	ANT58	\$189.95
AX-17C indoor active HF antenna	ANT60	\$189.95
AX-24B discone antenna	ANT63	\$319.95
WR-G3E-WMB Wall-mount Bracket for G3	BRK02	\$17.95
WR-DNC-3500 Frequency downconverter	CVR02	\$219.95
FSK Decoder	DEC01	\$399.95
WR-LNA-3500 low noise amplifier	PRE03	\$189.95
WR-PPS-G3 portable power supply for G3	PWR09	\$189.95
Trunking Software	SFT 23	\$59.95
G305 Advanced Trunking Option	SFT56	\$89.95
WaveBase 3	SFT60	\$59.95
ERD-1500 RF Sniffer	TST06	\$49.95
WR-AMFE-3500 MULTIPLEXER (special order)	ACC13	\$1,195.00
WR-BT-650 HF/VHF POWER INJECTOR (BIAS T)	ACC15	\$99.95
WR-CMC-30 COMMON-MODE CHOKE	ACC20	\$49.95
WR-AMFE-8600 MULTIPLEXER (special order)	ACC34	\$CALL
WR-ACD-1800 DUAL COMBINER (special order)	ACC39	\$189.95
WR-AX-37AH (special order)	ANT65	\$499.95
WR-AX-31CX (special order)	ANT66	\$189.95
AX-06B VHF/UHF ANTENNA (special order)	ANT68	\$29.95
WR-AX-31CMX (special order)	ANT69	\$289.95
AX-05E LONG WIRE HF ANTENNA	ANT71	\$39.95

Shipping/Handling Charges (UPS Ground)

Total Order	Shipping Charges
\$1-\$19.99	\$7.95
\$20-\$99.99	\$17.95
\$100-\$399.99	\$19.95
\$400-\$899.99	\$22.95
\$900-\$1499.99	\$25.95
\$1500-\$1999.99	\$26.95
\$2000-\$2499.99	\$28.95
\$2500+	\$32.95

Make sure to
visit us on the
web to get
the latest and
greatest deals!

GROVE

(800) 438-8155

Grove Enterprises, Inc. - www.grove-ent.com

(800) 438-8155; (828) 837-9200; fax: (828) 837-2216

7540 Hwy 64 W; Brasstown, NC 28902 - email: order@grove-ent.com

With a WiNRADiO receiver, you are always onto a winner.

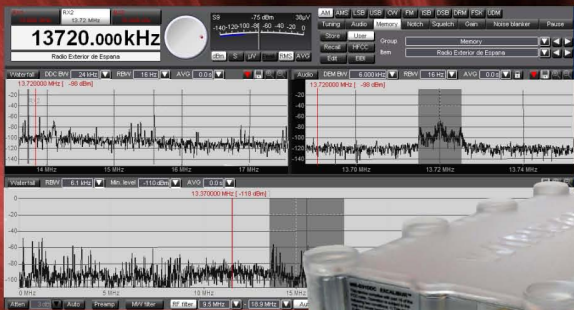

WinRadio Excalibur Pro

towards set-up measurement protocols but it is abundantly clear that the Excalibur Pro is better than anything we have hitherto encountered. To be able to connect a full-size 6/7MHz dipole to a receiver on an autumn evening and be able to observe the sideband sets of individual broadcasters down to virtually the receiver's noise floor is – to put it mildly – an unusual position for a reviewer to find himself in! Certainly the Excalibur Pro was not remotely troubled at any time by anything our various antennas could throw at it.

CONCLUSION

The Excalibur Pro is the best SDR we have used – in some ways it is the best receiver we have used regardless of the underlying architecture –

www.wrth.com

Overall rating ★★★★★



review

Mike Richards takes a look at the WiNRADiO G39DDC Excelsior, a receiver that some might consider the best software defined radio currently available.

If there's one thing that is likely to be at the top of a radio enthusiast's wish list, it's a system that can find signals quickly. The WiNRADiO G39DDC Excelsior certainly has the ability to do this and it must be something close to a dream receiver.

summary

ew, the WiNRADiO G39DDC Excelsior is a stunning receiver and a dream for me, I have only really covered the most interesting aspects of its performance.

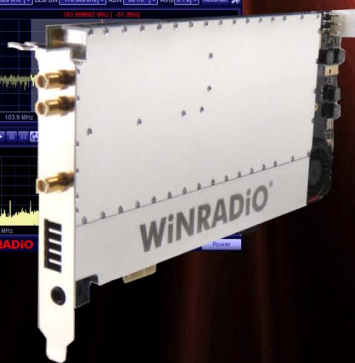
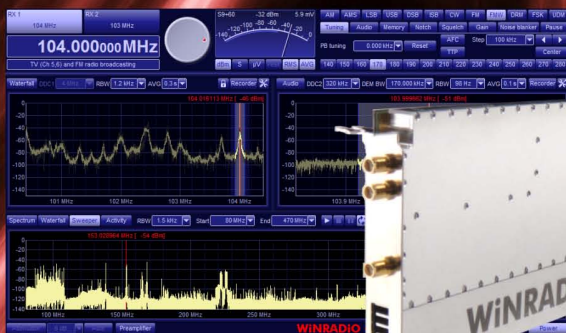

FIRST LOOK

MT Takes a Look at the Latest Tech

By Bob Grove, W8JHD

This is the most amazing receiver I've ever encountered. It employs the latest proven SDR architecture, operates well beyond the spectral range that most of us would ever think of trying to hear, and demodulates all conventional modes.

I ordinarily find something to complain about in my reviews, but trying to find something I don't like about the G39DDC has left me at a loss, and that's a gain for this winner.

We have lots of good gear. Take a look:
www.winradio.com/gear

WiNRADiO® by RADIXON®: Great receivers ahead of their time.™



Shortwave DX with a Crystal Set 8

By Dave Schmarder N2DS

A master crystal set builder and relentless radio experimenter, Dave Schmarder N2DS, likes a good challenge. In this month's cover story Dave tries the nearly impossible: DXing the shortwave bands with a crystal set.

Dave knows the problems only too well, "A major difficulty with shortwave crystal radios is the lack of selectivity." But, that's not all. Dave notes, "Crystal sets are about as sensitive as the proverbial Marine drill sergeant, so it's best to choose the bands with the strongest signals for reception."

Even so, crystal set builders soon find that crystal set construction brings the bulk of signals so close together and at such a reduction in strength that a DXer could go mad with the effort! But, not to worry, Dave has a couple of old school tricks up his experimenter's sleeve.

On Our Cover

Dave Schmarder N2DS's crystal set designed for shortwave. (Courtesy: Dave Schmarder N2DS)

C O N T E N T S

America's Voice for Asian Democracy 11

By Keith Perron

Regular contributor and long-time shortwave broadcaster Keith Perron examines Radio Free Asia (RFA) and the role it plays as a source for news and information in a region better known for state control of national and international broadcasts, particularly in China.

But, how does a broadcaster avoid the nearly constant attempts at jamming RFA's radio signals? Keith writes, "RFA uses frequencies that are not published and they change frequencies often. It might seem counterintuitive to shift or move a published frequency, but that's not the case with RFA. The attitude of people in China who listen is, 'Not to worry, we will find you.'"



RFA's North Korea broadcast studio. (Courtesy: Keith Perron)

Antennas for Shortwave Listening 13

By Bob Grove W8JHD

In part three of his new four part series on antennas, *MT* Publisher Bob Grove W8JHD looks at what's required for the best possible shortwave reception wherever you live and however much you might have to spend. Bob focuses on wire, active and loop antennas in shortwave application and discusses in detail such things as balanced line antennas, tuners, preamps and how to reduce noise on the shortwave bands that show up in your radio's speaker.

Shortwave Listening: The State of the Industry 16

By Ken Reitz KS4ZR

For the shortwave radio industry it's the best of times and the worst of times. Shortwave radios have never been more capable or more reasonably priced. From small portable sets to state-of-the-art Software Defined Radios capable of tuning in Digital Radio Mondiale, these are the golden days of shortwave radios.

But, with big international broadcasters leaving the air and opting for an online presence is there much of a future for the industry? *MT* asks four top shortwave industry observers to offer their views.

R E V I E W S

Tablerock "Shortwave Daddy" Receiver Kit 70

By Bob Grove W8JHD

Bob Grove knows one or two things about old school radio, but with the advent of surface-mount technology, micro-miniature parts, integrated circuits and special-purpose chips, aren't the old breadboard radios a thing of the past? No, says Bob, this radio, just as its breadboard predecessor of old, is a radio that's also a teaching tool. "Its primary goal is to satisfy those who would like to build a receiver that can be custom programmed for various settings," says Bob.



Uniden BC125AT Scanner 71

By Larry Van Horn N5FPW

Public service communications still offer plenty of interesting analog scanning, if you know where to look. But, is there an inexpensive and capable analog scanner on the market? Yes, says *MT*'s scanner guru Larry Van Horn, who also knows where to look for the most interesting stuff on the bands. He suggests the Uniden BC125AT; it's easy to program, loaded with high-end features and is a great bargain at just over \$130.

AR2300 "Black Box" Professional Grade Communications Receiver

Introducing a new generation of software controlled "black box" receivers!



Available in professional and consumer versions, the AR2300 covers 40 KHz to 3.15 GHz*

With the new AR2300 "black box" receiver from AOR, up to three channels can be monitored simultaneously. Fast Fourier Transform algorithms provide a very fast and high level of signal processing, allowing the receiver to scan through large frequency segments quickly and accurately. All functions can be controlled through a PC running Windows XP or higher. The AR2300 features advanced signal detection capabilities which can detect hidden transmitters. An optional external IP control unit enables the AR2300 to be fully controlled from a remote location and send received signals to the control point via the internet. It can also be used for unattended long-term monitoring by an internal SD audio recorder or spectrum recording with optional AR-IQ software for laboratory signal analysis. The AR2300 appeals to federal, state and local law enforcement agencies, the military, emergency managers, diplomatic service, news-gathering operations, and home monitoring enthusiasts.

Discover exceptional performance, state of the art specifications and a receiver with a menu of optional extras that can be configured to your own needs and specifications.

- Receives AM, wide and narrow FM, upper and lower sideband, CW modes, and optional APCO-25
- Up to 2000 memory channels (50 channels X 40 banks) can be stored in the receiver
- Alphanumeric channel labels
- Fast Fourier Transform algorithms
- Operated by a Windows XP or higher computer through a USB interface using a provided software package that controls all receiver functions
- An I/Q output port that allows the user to capture up to 1 MHz of bandwidth onto a computer hard drive or external storage device
- An SD memory card port that can be used to store recorded audio
- Analog composite video output connector
- CTCSS and DCS squelch operation
- Two selectable Type N antenna input ports
- Adjustable analog 45 MHz IF output with 15 MHz bandwidth
- Optional AR-I/Q Windows software facilitates the easy storage and playback of transmissions captured within up to 1 MHz bandwidth or, signals can be subjected to further analysis.
- An optional GPS board can be used for an accurate time base and for time stamping digital I/Q data.
- The triple-conversion receiver exhibits excellent sensitivity across its tuning range.
- Powered by 12 volts DC (AC Adapter included), it may be operated as a base or mobile unit.
- Software-driven operating selections include IF bandwidth, frequency, mode, filters, a screen-displayed graphical "S-meter," memory inputs, volume and squelch settings and more
- Professional (government) version is equipped with a standard voice-inversion monitoring feature



® The Serious Choice in Advanced Technology Receivers

AOR U.S.A., Inc.
20655 S. Western Ave., Suite 112
Torrance, CA 90501, USA
Tel: 310-787-8615 Fax: 310-787-8619
info@aorusa.com • www.aorusa.com

**Cellular blocked for US consumer version. Unblocked version available to qualified purchasers with documentation. Specifications subject to change without notice or obligation.*



MONITORING TIMES
(ISSN: 0889-5341;
Publishers Mail Agree-
ment #1253492) is
published monthly by
Grove Enterprises, Inc.,
Brasstown, North Caro-
lina, USA.

Copyright © 2012 Grove Enterprises, Inc. Periodicals postage paid at Brasstown, NC, and additional mailing offices. Short excerpts may be reprinted with appropriate credit. Complete articles may not be reproduced without permission.

Address: 7540 Highway 64 West,
Brasstown, NC 28902-0098
Telephone: (828) 837-9200
Fax: (828) 837-2216 (24 hours)
Internet Address: www.grove-ent.com or
www.monitoringtimes.com
Editorial e-mail: editor@monitoringtimes.com
Subscriptions: order@grove-ent.com

Subscription Rates: \$32.95 in US; \$42.95 Canada; and \$58.95 foreign elsewhere, US funds. Label indicates number of issues left. Renewal notice is cover sheet 3 months before expiration. **See page 76 for subscription information.**

WRITE FOR MONITORING TIMES:
Learn how at
www.monitoringtimes.com/html/write_for_mt.html or
write to editor@monitoringtimes.com

Postmaster:
Send address changes to *Monitoring Times*, 7540 Highway 64 West, Brasstown, NC 28902-0098.

Disclaimer:
While *Monitoring Times* makes an effort to ensure the information it publishes is accurate, it cannot be held liable for the contents. The reader assumes any risk for performing modification or construction projects published in *Monitoring Times*. Opinion or conclusions expressed are not necessarily the view of *Monitoring Times* or Grove Enterprises.

Subscription Questions?
belinda@grove-ent.com

Owners
Bob and Judy Grove
judy@grove-ent.com

Publisher
Bob Grove W8JHD
bobgrove@monitoringtimes.com

Editor Emeritus
Rachel Baughn KE4OPD

Managing Editor
Ken Reitz KS4ZR
editor@monitoringtimes.com

Assistant and Reviews Editor
Larry Van Horn N5FPW
larryvanhorn@monitoringtimes.com

Art Director
Bill Grove

Advertising Services
Judy Grove
(828) 837-9200
judy@grove-ent.com

TABLE OF CONTENTS

Departments:

Communications	6
Letters	74
Stock Exchange	76
Advertisers Index	76

First Departments

Getting Started

Scanning Report	20
<i>By Dan Veeneman</i>	
<i>Coping with old and new Radio Systems</i>	

Ask Bob	23
<i>By Bob Grove W8JHD</i>	
<i>Crowded FM reception; Satellite broadband and SDR reception; 700 MHz intermittent reception; Substitute coupler for H-800 active antenna; Where did all the drive-thru chatter go? Mars rover frequencies; C-band dishes; digital TV reception.</i>	

Utility World	24
<i>By Hugh Stegman NV6H</i>	
<i>SDRs: Opening a Larger Window</i>	

Digital Digest	27
<i>By Mike Chace</i>	
<i>Fall Digital Smorgasbord</i>	

On the Ham Bands	28
<i>By Kirk Kleinschmidt NT0Z</i>	
<i>Linear Amplifiers: Myth vs. Reality</i>	

Beginner's Corner	30
<i>By Ken Reitz KS4ZR</i>	
<i>The More Things Change, the Better they Get...Mostly</i>	

Programming Spotlight	32
<i>By Fred Waterer</i>	
<i>Weekend Shortwave Radio</i>	

Second Departments	
QSL Report	34
<i>By Gayle Van Horn W4GVH</i>	
<i>QSL Contact Updates</i>	

English Language SW Guide	35
MTXtra.Shortwave Broadcast Guide 48	
<i>Spanish</i>	

Second Departments

QSL Report	34
<i>By Gayle Van Horn W4GVH</i>	
<i>QSL Contact Updates</i>	

English Language SW Guide	35
--	-----------

MTXtra.Shortwave Broadcast Guide 48	
<i>Spanish</i>	

Milcom	52
<i>By Larry Van Horn N5FPW</i>	
<i>Milcom HF Aero OR Band Scan Survey</i>	

Broadcast Bandscan	54
<i>By Doug Smith W9WI</i>	
<i>Digital Radio in Mexico</i>	

BOATS, Planes, Trains	56
<i>By Ron Walsh VE7GO</i>	
<i>Fall Listening</i>	

Globalnet	58
<i>By Loyd Van Horn W4LVH</i>	
<i>"Arrrr, There be Radio in Them Os and Is!"</i>	

Below 500 kHz	60
<i>By Kevin Carey WB2QMY</i>	
<i>ID Please?</i>	

Technical Departments

Radio Restorations	62
<i>By Marc Ellis N9EWJ</i>	
<i>The Howard 430 – a Brand New Project</i>	

Sky Surfing:	
Amateur Radio Satellites	64
<i>By Keith Baker KB1SF/VA3KSF</i>	
<i>A Flock of other Amateur Radio Satellites</i>	

Computers and Radios	66
<i>By Brian Wood W0DZ</i>	
<i>DIY Computers</i>	

On the Bench	68
<i>By Ken Reitz KS4ZR</i>	
<i>Newstar DR111 Digital Shortwave Radio</i>	

First Look	70
<i>Tablerock "Shortwave Daddy" Receiver Kit</i>	
<i>By Bob Grove W8JHD and Uniden BC125AT</i>	
<i>Scanner By Larry Van Horn N5FPW</i>	

What's New	72
<i>By Larry Van Horn N5FPW</i>	
<i>Domestic Broadcast Survey 2012; Icom Loan Program with Boy Scouts; DX Engineering's new Coax; Utility DXers QSL Address Handbook; MFJ IntelliTuner released; RigExpert AA-1000; New Array Solutions Coax Surge arrester.</i>	

You may contact any MT staff writer by email by combining their **first and last name @ monitoringtimes.com**. By postal mail, you may write them in care of MT Headquarters in Brasstown. Please enclose a self-addressed, stamped envelope if you wish the columnist to reply.

Study with the best!
License Study Materials by

Gordon West, WB6NOA & the W5YI Group



TECHNICIAN CLASS



Technician Class book for the 2010-2014 entry level exam! Gordo reorganizes the Q&A into logical topic groups for easy learning! Key words are highlighted in his explanations to help you understand the material for test success. Web addresses for more than 125 helpful, educational sites. Includes *On The Air CD*

demonstrating Tech privileges. **GWTM \$20.95**

Tech Book & Software Package

Gordo's book with W5YI software allows you to study at your computer and take practice exams. Explanations from Gordo's book are on the software - answer a question wrong and his explanation appears to reinforce your learning. Includes free Part 97 Rule Book. **NCS \$29.95**

Tech Audio Course on CD

Welcome to Gordo's classroom! Technician audio theory course recorded by Gordo talks you through the Element 2 question pool. Follows the order of his *Technician Class* book, and is full of the sounds of ham radio operating excitement! An excellent study aid if you spend a lot of time in your car or pick-up! On 4 audio CDs. **GWTW \$29.95**

GENERAL CLASS



General Class book Upgrade to the HF bands with Gordo & W5YI! Gordo's manual for 2011-2015 reorganizes all the questions into logical topic groups for easier learning. His explanations include highlighted key words to help you remember the material for test success. Companion CD is full of great operating tips! Available about May 1st. **GWGM \$24.95**

General Book & Software Package

Study at your computer and take practice exams. Software includes explanations from Gordo's book, scores your results and highlights areas that need further study. Includes free Part 97 Rule Book. **GUS \$34.95**

General Audio Course on CD

General Theory Course recorded by Gordo is full of the sounds that bring ham radio to life! He talks you through the Element 3 theory to help you understand the material and get you ready for your upcoming exam. On 4 audio CDs. **GWGW \$29.95**

EXTRA CLASS



Extra Class book Go to the top with Gordo! 2008-2012 book includes all Element 4 Q&A reorganized into logical topic groups. Gordo's fun, educational explanations with highlighted keywords, and great memory tricks for those tough theory questions! Wait 'til you meet "Eli the Ice Man!" **GWEM \$24.95**

Extra Book & Software Package

Study at your computer and take practice exams as the W5YI software scores your results and highlights areas that need further study. Includes explanations from Gordo's book. Free Part 97 Rule Book. **ECS \$39.95**

Extra Audio Course on CD

Extra Class Theory Course recorded by Gordo talks you through the difficult Element 4 theory to help you understand the material and get you ready for your upgrade to the top. On 6 audio CDs. **GWEE \$39.95**

Ham Operator Software has All Exams

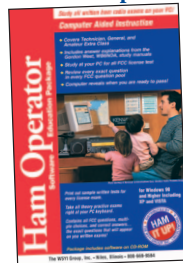

Want to study at your computer without tying up your internet connection? This value pack includes the Tech, General and Extra class exams (Elements 2, 3, and 4) along with a free Part 97 Rule Book. Software includes Gordo's answer explanations from his books! Everything you need to go all the way to the top!

Software only **HOS \$29.95**
 Software with all 3 West Books **HOSB \$89.95**



Using Your Meter

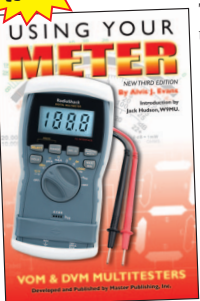

Teach yourself the correct use of your multimeter. Book explains fundamental concepts of electricity including conventional and electron current and series and parallel circuits. It teaches how analog and digital meters work and tells you what the voltage, current and, resistance measurements mean. Then it provides fully-illustrated, step-by-step instruction

on using your meter in practical applications in the home, workshop, automotive and other settings. An excellent learning tool and reference for the hobbyist and ham. **METR \$24.95**

GROL + RADAR

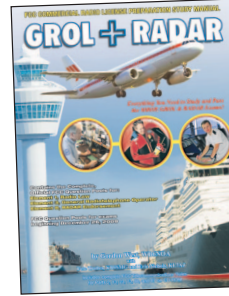

Get your FCC commercial radio licenses and add valuable credentials to your resume! **GROL+RADAR** includes the new FCC Element 1 question pool for the Marine Radio Operator Permit (MROP), the Element 3 pool for the General Radiotelephone Operator License (GROL), and the Element 8 pool for the RADAR Endorsement. Many employers require these licenses for jobs in marine, aero, safety, and municipal positions. Gordo and his team have written clear explanations for all the Q&A to make studying for these exams educational and fun. If you're an Extra Class ham, many of the technical/math questions will look familiar to you. Fully-illustrated to aid your learning. Book includes a searchable CD-ROM with all FCC Rules for Parts 2, 13, 23, 73, 80 and 87. **GROL \$49.95**

GROL+RADAR book & software package

Enhance your learning experience using our practice exam software along with the **GROL+RADAR** book. Software includes answer explanations from the book - when you select a wrong answer, the explanation from the book appears to reinforce your learning. **GRSP \$79.95**

Getting Started in Electronics

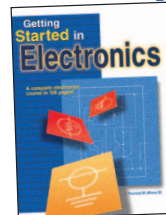

by Forrest M. Mims
 A great introduction for anyone who wants to learn the fundamentals of electronics. Includes 100 projects you can build, and great experiments that demonstrate how electricity works! **GSTD \$19.95**

Engineer's Mini Notebooks



These Mims classics teach you hands-on electronics! Study and build 100s of practical circuits and fun projects. Each volume contains several of his famous Mini Notebooks. Terrific ideas for science fair projects and a great way to learn about electronics!

Useful reference guides for your workbook!

- Vol. 1: Timer, Op Amp, & Optoelectronic Circuits & Projects** **MINI-1 \$12.95**
- Vol. 2: Science & Communications Circuits & Projects** **MINI-2 \$12.95**
- Vol. 3: Electronic Sensor Circuits & Projects** **MINI-3 \$12.95**
- Vol. 4: Electronic Formulas, Symbols & Circuits** **MINI-4 \$12.95**

Order today from W5YI: 800-669-9594 or on-line: www.w5yi.org

The W5YI Group P.O. Box 200065 Arlington, TX 76006-0065

Mention code 053736 for a free gift with your order!



COMMUNICATIONS

by Ken Reitz



OBITUARIES

QST's Joel Kleinman N1BKE SK

The ARRL announced August 21 the passing of *QST* Managing Editor, Joel Kleinman N1BKE who died as a result of injuries received during a house fire at his home in Meriden, Connecticut. Kleinman, 64, graduated from the University of Montana with an MA in Journalism and began work at ARRL headquarters in 1976, according to a statement from the ARRL. He held numerous editing and supervisory roles in various aspects of League publishing and became Managing Editor of *QST* in 2001.

The cause of the fire was still under investigation at press time. Kleinman's wife Jayne survived the fire but was in intensive care at a local hospital, according to an ARRL press release. "Joel was a gifted writer and editor," ARRL Chief Executive Officer David Sumner K1ZZ said in the press release, "Amateur Radio is the richer today because he chose to devote his talents to the work of the ARRL."

AMATEUR RADIO/SHORTWAVE

FCC: No 2 Meter Emergency Channel

The FCC has denied a petition brought before the Commission by two amateur radio operators asking that 146.550 MHz in the 2 meter band be designated as a "nationwide emergency calling frequency." The two had argued that other services, notably CB, aviation and marine had such dedicated channels.

In denying the petition the Commission noted that amateur operating rules require every amateur frequency to be available for emergency communications. It noted too that it had earlier denied a petition to establish a similar channel with the Family Radio Service for the same reason. It explained that the flexibility of the amateur service provided that emergency operations could take place not only on several frequencies within the same band, but on several bands as well, depending on the nature of the emergency and local conditions.

The Commission further suggested that, "nothing in our rules prevents the amateur community from voluntarily agreeing to designate a channel for this purpose."

AM/FM/TV BROADCASTING

Cord-Cutting Surprises Analysts

Pay-TV industry analysts were surprised when more than 400,000 cable-TV customers dropped the service in the first half of 2012 and satellite programming provider DirecTV lost more than 50,000 customers in the second quarter of the year alone. These statistics, from a *Reuters* report carried in many U.S. newspapers including the *Columbus Dispatch*, were blamed on continued high unemployment and a weak housing market.

Even though the numbers are relatively small, compared to tens of millions of subscribers who did not drop their service, the trend remains negative. Time Warner Cable, for example, suffered its tenth straight quarterly loss of customers. Others saw negative figures as actual gains, for example, DISH Network lost 10,000 subscribers in the quarter and saw that as an improvement over previous quarters in which the company lost more subscribers.

The combination of lagging home sales; fewer new households being formed (kids are staying with their folks to ride out the never-ending recession); slowed immigration rates, and savings minded family budgets looking to cut big-ticket monthly bills to save money, have virtually stopped growth among cable and satellite-TV programming providers. Even so, by continuing to raise rates, these companies are still quite profitable.



Winegard UHF-TV antenna. (Courtesy: Winegard)

SATELLITES

Russian Launch Woes Continue

The launch failure of two telecommunications satellites by a Russian booster rocket in early August made headlines in many news outlets worldwide. The two satellites had been intended to provide service for Indonesian and Russian customers. The booster, which was supposed to place the satellites in a transfer orbit after an 18 minute burn, cut out after only seven seconds. While the exact cause is under investigation, the Russian Deputy Prime Minister, who oversees Russia's military, suggested the cause was aging leadership.

Russian Prime Minister Dmitri Medvedev was quoted on *NBC News* as saying of the disas-

ter, "We are losing authority and millions of roubles." He ordered an investigation to make recommendations as to, "who to punish and what to do further."

The mishap came the same week the U.S. space agency NASA was enjoying the successful landing of the Mars explorer Curiosity. The Russian rocket failure was particularly annoying because just two months before, China successfully launched their own astronauts on a mission to rendezvous with an orbiting module that provided practice for their own eventual Chinese-only space station.

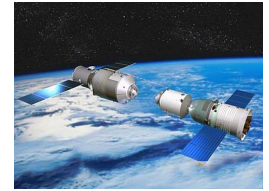

Tiangong-1 (left), the Chinese practice docking station, and Shenzhou VIII (right) spacecraft docking in an artist's conception. (Courtesy: China Today)

PUBLIC SERVICE

Oakland Radios Fail (Again)

In one of the best documented cases of P-25 public safety radio system failures, the system used by the city of Oakland, California continues to flop. An article in the *Oakland Tribune* from mid-July reported that the system "had so many glitches that officers say they now have trouble even talking to each other." Having paid \$18 million (much of it from federal grants), the city is waiting for an estimate for how much it will cost to fix it. The city will spend the next six months "upgrading the infrastructure, training workers and monitoring more closely for system failures." No doubt they'll also be hoping there won't be any major problems while they try to fix the system. They'll also hope the fix won't cost too much.

Allentown (PA) PD Encrypts

An article in the Allentown, Pennsylvania *Express-Times* detailed the switch that city's police department made from analog to digitally encrypted transmissions. According to the article, city officials claimed officer safety and operational security as the reasons to encrypt. The "up-grade" to the encrypted system will cost the city over \$1 million for the privilege of keeping the public out of their public service radio system.

But, the move was criticized by the Pennsylvania Newspaper Association which noted that the Pennsylvania state police and other de-

partments had also encrypted. A spokesperson for the association, according to the article, said, "We already have abysmal access to police records under Pennsylvania's Right to Know law and this is just one more barrier that prevents the public from finding out what's happening in their community." The new encrypted system is not interoperable with nearby townships or the city's own fire and EMS which remain with unencrypted systems.

TECHNOLOGY

Police Cell Phone Spying Rises

According to a news report from *Reuters*, American police agencies issued 1.3 million requests to cell phone providers for their customers' records in 2011. The report indicates that number is on the rise from the previous year. And, according to an article from March 31 this year in the *New York Times*, police agencies nationwide, big and small, are in on the activity "with little or no court oversight." Cell phone service providers have turned the activity into a cash cow, actually marketing "a catalog of 'surveillance fees' to police departments to determine a suspects location, trace phone calls and texts or provide other services..." according to the article.

The *Times* article was based on records collected by the American Civil Liberties Union (ACLU) from more than 200 police departments nationwide which were provided to the newspaper. Among the practices revealed in the probe: Police in several states got phone companies to identify all calls made through certain cell towers in nonemergency investigations; California police agencies were advised on how to "clone" a phone to download text messages while the phone is turned off; some police departments skipped the middleman by buying their own tracking equipment; police training manuals even advised trainees not to mention such activities to the press or public and not to put such information in police reports, according to the article.

It shouldn't come as any surprise that police agencies switching to P25 systems also want to opt for encryption. Under the guise of officer safety or security concerns, encryption may be seen as the ultimate way to hide possibly unconstitutional police activities from public or legislative scrutiny.

FCC to Study RFR

According to an article in *Broadcasting & Cable* magazine, three Democratic members of Congress have asked the FCC to revisit its fifteen year-old guidelines for mobile devices Radio Frequency Radiation (RFR) standards. According to a report issued in late July by the Government Accountability Office (GAO), "Scientific research to date has not demonstrated adverse human health effects of exposure to radio-frequency (RF) energy from mobile phone use, but research is ongoing that may increase understanding of any possible effects." A summary of the GAO study may be found here: <http://www.gao.gov/products/GAO-12-771> The full document runs

46 pages and may be found on the same page as the summary.

The reason for the request for an update has to do with the change in cell phone technology since 1996, the last time the FCC addressed the subject, and, perhaps more importantly, how cell phones are used and the current saturated nature of the cell phone landscape that includes several hundred thousand additional higher powered towers and hundreds of millions of new cell phones. According to industry figures, in 1996 only 16 percent of the U.S. population used cell phones. Today, that number exceeds 100 per cent.



Radiation from cell phone technology to be studied by the FCC. (Courtesy: Research Center for Wireless Technology)

The National Telecommunications Industry Association (NTIA), the biggest lobbying group for the cell phone industry and which is well represented among the five FCC commissioners, says that studies previously done have shown no link between such devices and the public health. In fact, the FCC's web site refers those wanting to know more about RF radiation to OET Bulletin #56 titled, "Questions and Answers about Biological Effects and Potential Hazards of Radio frequency Electromagnetic Fields." That publication was last updated August, 1999.

The Occupational Safety and Health Administration (OSHA) would be a likely place to find radio frequency radiation standards, especially for the workplace. The OSHA website claims that, "Research continues on possible biological effects of exposure to Radio Frequency/Microwave radiation from radios, cellular phones, the processing and cooking of foods, heat sealers, vinyl welders, high frequency welders, induction heaters, flow solder machines, communications transmitters, radar transmitters, ion implant equipment, microwave drying equipment, sputtering equipment and glue curing." OSHA advises that, "There are no specific standards for radiofrequency and microwave radiation issues."

There appears to be little appetite among government agencies charged with protecting public health in tackling the study of possible problems associated with the cell phone industry which rakes in some \$170 billion annually. And, according to opensecrets.org, a non-profit organization that tracks political contributions, the communications/electronics industry padded the campaigns of both parties with nearly \$140 million in the 2008 election cycle. With the Supreme Court having lifted restrictions on organizational donations, there's no telling how much the industry is giving this time around, but a safe bet is that funding hasn't gone down.

FCC ENFORCEMENT

Free Radio Olympia Busted

For more than a decade Free Radio Olympia has operated an unlicensed, high-power FM radio station on 98.5 MHz in Olympia, Washington. On June 20 this year FCC field agents located the source of FRO at a residence in that city and measured the FRO transmitter as putting out better than 1.8 million microvolts/meter at three meters, possibly the most powerful unlicensed FM station yet busted. Unlicensed operation in the FM band is limited to 250 microvolts/meter at three meters under Part 15 rules. The agents left a Notice of Unlicensed Operation (NOUO) with two individuals who were listed as owners of the property at which the station was located. A notice posted on the FRO website stated, "Off Air Starting 7/28/2012" and advising "We will be off the air for a little while starting Saturday due to technical difficulties for an unknown amount of time. We will still be streaming online during this time and we will hopefully be back up soon!" Expect major fines for this long-running operation.

Communications is compiled by Ken Reitz KS4ZR (kenreitz@monitoringtimes) from clippings and links provided by our readers. Many thanks for this month's fine reporters: Anonymous, Bob Grove, Normal Hill, Robert Kelty, Steve Karnes, and Larry Van Horn.

NASB

National Association of Shortwave Broadcasters

Representing the privately-owned shortwave stations in the USA

- Find links to all of our members at www.shortwave.org
- Take the NASB Shortwave Listener Survey and get a free subscription to the NASB Newsletter. www.surveymonkey.com/s/6LRVLJ7
- Listen to "The Voice of the NASB" on HCJB's DX Party Line on WRMI's 9955 kHz. Visit www.wrmi.net for schedule
- NASB is a member of the HFCC (High Frequency Coordination Conference) and the DRM (Digital Radio Mondiale) Consortium

Shortwave DX with a Crystal Set

By Dave Schmarder N2DS
(Photos and schematics courtesy of the author)

As a child of the mid-twentieth century growing up in a radio household, listening to stations located on other continents was commonplace for me. As a teen it was exciting to hear the latest Beatles tune via the BBC, or hearing the “those Reds” coming over on Radio Moscow. Even listening to the strange noises was exciting. It was only later that I realized that most others didn’t know about the shortwave secret in those days before satellite television and the Internet.

Besides shortwave radio listening, one of my other hobbies is building crystal sets. These small, no-power-required radios had long since become obsolete for the masses, but still held a fascination with the kids and experimenters.

Crystal Sets of Long Ago

The crystal set was an early type of receiver invented soon after wireless developed in the early twentieth century. Three element or triode vacuum tubes had been invented but their use in wireless communications was still a ways off. Various types of detectors were experimented with, and the galena rock detector was found to be one of the most sensitive for hearing spark transmitters. Wireless was mostly thought as a maritime service, especially after the Titanic disaster 100 years ago. The word “radio” hadn’t yet been coined.

Radio was born with the introduction of scheduled broadcasts offered by KDKA in Pittsburgh, Pennsylvania, and a handful of other stations, and a new industry was born. Many fortunes were made (and some lost). The patent lawyers of the day put their kids through college because of radio. You can think of radio as the dot com boom of the 1920s.

The crystal set played a major role in the development of radio, but it’s time in the sun was only a couple of years. By 1923, crystal sets were being placed on the shelves to gather dust and replaced by the better performing vacuum tube sets. According to Radio Broadcast Magazine, a trade publication of the 1920s (available at archive.org), the reception range of a crystal set was, at best, about 25 miles.

Radio stations at the time often operated at less than 100 watts of power, with 1000

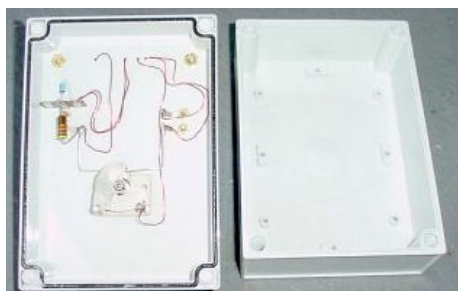

Uncluttered Inside of the Simple Shortwave Crystal Set.

Coil: 1.6 inch o.d. 23awg Wire
Antenna: 5 turns
Detector: 30 turns tapped at 20turns.

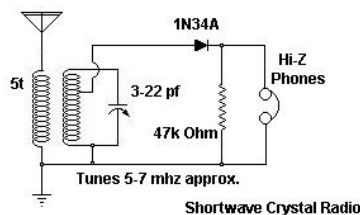

Simple Shortwave Schematic.

watts being “blowtorch” power levels. Also, the materials used to make the components of a crystal set were generally poor due to high frequency losses. So it is no wonder that the crystal set was a quick, flash-in-the-pan fad.

As the vacuum tube took over the radio reception heavy lifting, a new phenomenon was discovered. The innovators of the day found that by shortening the wavelength (raising the frequency), radio signals would travel hundreds and even thousands of miles, in the middle of the day too! Everyone started a California style gold rush to the shorter waves with vacuum tube receivers.

Crystal Sets of Not-so-Long Past

Shortwave crystal sets have been a curiosity in the hobbyist publications over the years. The magazines of the 50s and 60s were especially keen on bringing the

most sensitive or selective radio project to the reader’s attention. These fond memories encouraged me to revisit crystal set building and design techniques. In the scores of crystal sets that I built (<http://makearadio.com/crystal>) a couple of them were built to receive shortwave stations.

Some builders of very simple single coil crystal sets have reported hearing stations at great distances, and thought they were hearing medium wave stations. It was found that some crystal sets exhibit multiple tuned circuit resonances and shortwave stations are heard under certain conditions. These “shortwave ghosts” are usually eliminated with better filtering arrangements. This has caused some hobbyists to investigate building crystals that would intentionally receive shortwave stations.

The Challenges

Building a simple shortwave crystal set is easy and inexpensive. Building a good performing radio is more difficult and knowing a few tips ahead of time is helpful. Shortwave receiver design is different from medium or longwave band sets so here are some takeaways from my research and projects:

Crystal radios can only detect amplitude modulated (AM) signals. FM signals can be demodulated by using a method called “slope detection,” but it’s really AM detection. Morse code (CW) signals can’t be demodulated and single sideband (SSB) signals are hard to understand, due to the missing carrier signal, so crystal set reception is AM only. This leaves only two reception possibilities, broadcasters or ham radio operators.

Since crystal sets are about as sensitive as the proverbial Marine drill sergeant, it is best to choose the bands with the strongest signals for reception. The loudest shortwave signals can be found during the evening hours on the 60, 49, 41 and 31 meter bands (5 - 10 MHz). The best frequencies to hear AM ham radio stations are on 3880 kHz (75m) and 7290 kHz (40m). Although not shortwave, AM hams can also be easily heard on 160 meters during the winter months.

A major difficulty with shortwave crystal radios is the lack of selectivity. It is all in the numbers simply stated as the circuit Q. The higher the Q, the better the selectivity. Q is a percentage of the bandwidth of a tuned circuit (coil and capacitor in a resonant circuit). The bandwidth is determined by measuring or cal-



A Simple Shortwave Crystal Radio.

culating a tuned circuit where the bandwidth is the two points at which the voltage drops to 70.7% from the peak value at center resonance. These are the 3dB points. This number is then compared to the operating frequency in a ratio. A 10 kHz bandwidth at 1 MHz (the center of the MW band) represents 1.0%. The Q increases as the bandwidth percentage decreases.

The issue at shortwave is that the frequency is much higher, 6 times higher at the popular 49 meter band. That same 1% bandwidth is now 60 kHz! About 20% of the 49 meter band would be heard at once at less than a 3db signal reduction. The Q values can't be raised high enough. The coil and capacitor elements are just not good enough for single signal reception.

But don't be discouraged. It just takes a bit more skill, a good practical receiver design and patience to clearly hear lots of stations. The stations fade up and down. This is also true at the MW broadcast band but is more pronounced at shortwave. So you wait, and keep listening until you get that all important fade up during station identification.

Shortwave Crystal Set Design Tips

Once you've thought of your basic strategy, it is time to put on the thinking cap to decide on the design specifics of your radio. Many use the old axiom, "Design twice, solder once." But I say, "Experimentation is Bliss!"

To start, a decision needs to be made on the actual frequency range. Many opt for the several bands in one tuning range. With this design there is only one non-removable coil, without a band changing switch. If a smaller tuning range is desired, select a low value variable capacitor, such as a 25pF capacitance value. The coil winding turns can be tweaked to tune the band you want. This allows for the easiest tuning without need for vernier drive or other mechanical methods to slow down the tuning rate.

A 100pF variable capacitor is likely to tune two bands and the old time popular 140 pF shortwave variable may tune three bands. At that point, you may want to consider making the tuning easier with a vernier drive or at least an oversized tuning knob. Since the selectivity is not very good, a great effort in tuning ease isn't a big requirement, but may help you get that one station with a couple of degrees movement of the capacitor shaft.

The question is often asked about multiple tuned circuits in tandem to improve selectivity. Yes, anything that can be done to improve selectivity is desirable, as long as the losses of the extra components don't cripple the sensitivity too much. I would certainly give my blessing to two tuned circuits, separately tuned.

In the case of two tuned circuits, connecting the antenna and ground to one coil/variable capacitor and placing the coil near the detector coil is probably the best way to build your radio. Make sure to experiment with different circuit arrangements before building your finished radio. Coils should be wound with solid wire, rather than Litz wire due to the lack of

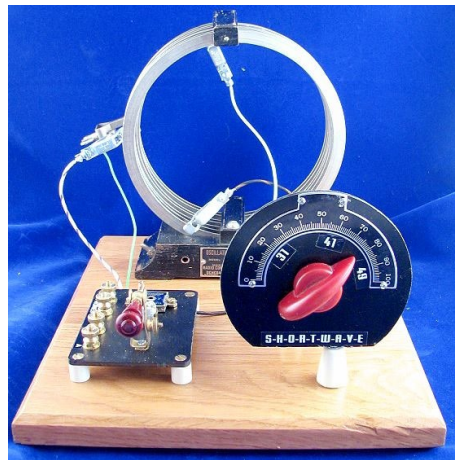

My Second Shortwave Crystal Set As Originally Built.

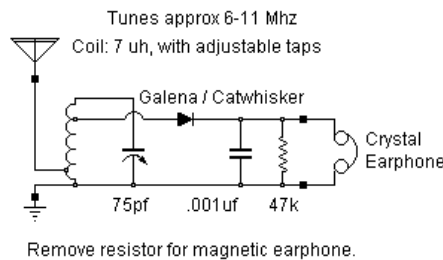

Second Shortwave Crystal Set Original Schematic.



Shortwave crystal set close-up shows galena crystal detector.

efficiency of Litz at shortwave frequencies. Litz wire is made of a number of individually insulated wire strands (sometimes hundreds) that are woven together and works best at medium wave and longwave frequencies.

The next design consideration is the detector and audio output sections. The detector is a plain old tried and true 1N34A germanium diode. Everyone who has built a crystal set or two knows that part number. Certain Schottky diodes also make good crystal set detectors. Look for ones with less than 1pF junction capacitance to work well as a detector.

To reduce the loading by the detector and audio output stage on the tuned circuit, placing the diode connection about half way down the coil is recommended. Again, it's the selectivity vs. sensitivity dilemma. Moving the diode up higher on the coil away from the grounded end will increase the sensitivity, but it will be at the expense of putting a high resistance load on the entire tuned circuit. But a lower tap position of

Monitoring Times

Explore the Spectrum
for only

\$19.95
Per Year

Mention that you learned about us in MT and get 3 FREE MONTHS of MTXpress!

MONITORING TIMES EXPRESS

Every Month for One Full Year you'll get MTXpress: Full Color, Interactive links, delivered to your iPad, laptop, desktop or smartphone. Now, tune in to the whole spectrum from longwave to super UHF. Learn about the frequencies, the rigs, and the antennas that make it all happen from the writers who know their stuff. Not

sure? Go to

www.monitoringtimes.com

to download a free sample or call 800-438-8155.

CALL NOW!

800-438-8155

www.monitoringtimes.com

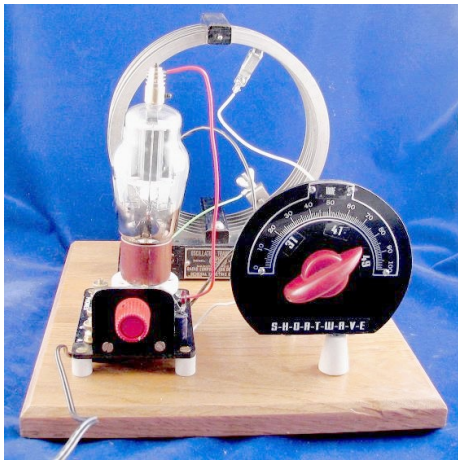

Rebuilt second shortwave crystal radio, now a tube radio.

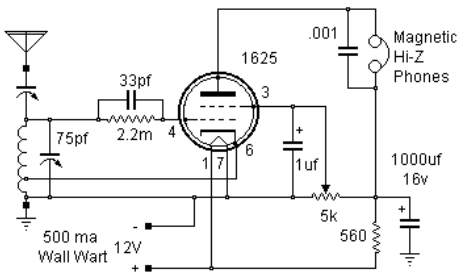

#58 - 1625 Shortwave Tube Radio (c) 2006, D. Schmarlder
One Tube Radio Schematic.

the coil may not allow the diode and the tuned circuit to operate as efficiently as possible. There is a happy point tapping somewhere in the middle of the coil.

Using sensitive high impedance headphones is a must. Use well adjusted balanced armature phones if you can find them. Piezo element phones also work well and can be cheaply built. I wrote an article some time ago about this on my website. (<http://makearadio.com/misc-stuff/piezophones.php>)

Also, use an audio frequency matching transformer between the detector and headphones. The tuned circuit loading is reduced and the diode can be tapped at a higher position on the coil, away from the grounded end. The resistor in parallel with a capacitor equalizes the impedance vs. resistance values for less loading on the tuned circuit.

A Bogen model T725 transformer is an inexpensive matching transformer with many connection combinations. I've built a lot of crystal sets using this part. You may be lucky enough to find one of the old time audio matching transformers that have a much higher input impedance.

My DIY Shortwave Crystal Radios

Several years ago I put together a little shortwave crystal radio. It was built in a plastic box. All the parts were from my junk box, so the cost was nil and the fun factor large. This radio uses a dual coil arrangement where the

antenna and ground are connected to one 5 turn winding on a 1.5 inch diameter painted cardboard tube. This provides the signal, absorbed by the main tuned coil, with 30 turns of wire on the same form. The diode is tapped 20 turns from the bottom. I used 23 AWG insulated magnet wire, also a junk box find. Wire much larger in diameter wire will work better, but the coil dimensions would need to be changed.

I used a crystal type earphone in this design, which requires a resistor to be placed across it to provide a direct current path for the diode detector circuit to work. Crystal or piezo phones are very high resistance devices (20 megohms being typical) and act as an open circuit. Magnetic style earphones don't require this shunt resistor as the phones themselves provide relatively low resistance path needed to complete the detector circuit.

The variable capacitor is 22 pF with ceramic insulators, making it a low loss style, good for this project. Nothing is critical in this radio, so look and see what you have before purchasing items.

Turning Failure into Success

Sometimes a project doesn't work out and it ends up quite different. Such was the case with my second shortwave crystal radio, which I affectionately named #58. (<http://makearadio.com/crystal/58.php>) As part of an online auction treasure, I ended up with an "oscillation transformer," an old spark gap transmitter component. This looked like a great coil to build another shortwave crystal radio. After measuring the coil, and pairing it with a variable capacitor, I found the radio would tune from about 6 to 10 MHz. That was perfect for the best evening listening bands, those being the 49, 41 and 31 meter broadcast bands.

To add to the old time look and feel of this radio, I added a galena cat-whisker detector. This looked like the perfect eye candy to show off to everyone on my website. Unfortunately, the radio didn't work worth a hoot. Maybe it was the low sunspot number, time of year or whatever. It did work but not with the expected performance.

Then I had the epiphany of turning this beauty in to a one tube regenerative shortwave receiver. I took out the detector, made a few other changes to the chassis board and added a big 1625 transmitting tube. This saved my project! I had hoped for a shortwave crystal set but was quite happy to have a cool looking one-tube radio.

My Suggested Radio Design

I designed a dual coil shortwave crystal set especially for *Monitoring Times* readers. I promise that this radio will bring you hours of building and operating fun. There is a lot of latitude in how you build it. Before purchasing anything, have a look in your junk box for parts that are close.

The schematic shown is a dual coil set.

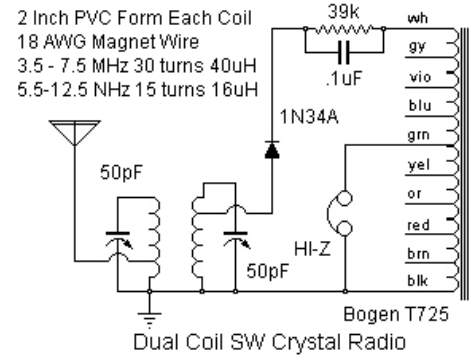

Dual Coil SW Crystal Radio
The MT Special Dual Coil Shortwave Crystal Set Schematic.

The antenna is connected to a tap on the first coil. This tap can be placed about 25% up from the bottom of the coil for longer outside antenna connections. If your antenna is much shorter, the tap can be as high as 50% up from the bottom.

The coil distances should be made adjustable if possible, but they'll generally be less than 3 inches apart. The diode can be placed on a tap about half way up the coil. This should offer reasonable performance and a good match to the Bogen T725 transformer. These transformers are available from electronic parts distributors, or online hobby radio parts sellers such as Peebles Originals (<http://peeblesoriginals.com>). Mike Peebles also offers high impedance headphones made from piezo elements. If you wish to make your own piezophones, I have some extra elements available.

I calculated the inductance and winding values for two frequency ranges. The largest coil will allow coverage of the 75 and 40 meter ham bands as well as several popular shortwave broadcast bands. The smaller coil moves the frequency range higher to tune the 31 and 25 meter shortwave bands but leaves out the 75 meter ham band.

After building, connect the radio to your antenna and ground and wait for the sun to go down. The tuning controls won't be real sensitive, but should be adjusted to the same dial position to begin. Once you hear a station, rock the two capacitors back and forth to peak the signal. Note the shaft positions as those relative positions will remain about the same throughout the tuning range. This is how radio listeners in the mid 1920s operated their Atwater-Kent sets before some smart person invented the ganged variable capacitor.

I hope you enjoyed building your shortwave crystal set. Make sure to show it off to everyone because, whether they are young or old, they will be amazed at your scientific and mechanical expertise. Let me know how your project works.

About the author:

Dave Schmarlder N2DS operates Dave's *Homemade Radios* at <http://makearadio.com>. He may be reached at davesch55@stny.rr.com. Dave is also webmaster for peeblesoriginals.com, a source for radio parts and kits for crystal sets and tube radios.

America's Voice for Asian Democracy

By Keith Perron

Radio Free Asia (RFA) was born from the crackdown in Tiananmen Square in 1989. While it's true that other international broadcasters such as the Voice of America, BBC World Service and others had programming that targeted China, RFA's mandate was different. It has a similar mission to stations like Radio Free Europe and Radio Liberty which were aimed at those European nations that were part of the former Soviet Union or under Soviet Union influence.

Under the provisions of the 1994 International Broadcasting Act, the station was founded on March 12, 1996 and by September of that year RFA was on air. The core mission for RFA is to provide news and information to Asian nations where freedom of information is limited. These areas include China, Burma, Laos, Vietnam, Cambodia, and North Korea.

The largest area they cover is China. To China alone they broadcast in four languages: Mandarin 12 hours a day; Cantonese 2 hours a day; Uyghur 2 hours a day, and Tibetan in three dialects for 10 hours a day.

Blocking Asia's Free Voice

One of the main challenges for RFA is reaching its audience. To do so they broadcast via shortwave, satellite, medium wave and through the Internet. Virtually all of RFA's broadcasts targeting China are jammed and its website is blocked. But, one of the advantages shortwave broadcasting has over Internet delivery is that radio jamming is not one hundred percent.

At any one time RFA could have a number of frequencies on the air and the chances of jamming each frequency is very slim. From my own personal experience with listening to RFA in China, I discovered jamming was concentrated

in certain areas. While I could not pick up RFA on any of its frequencies in Beijing, I discovered that if I was 100 kilometers or more outside the capital, it was easy to find one or two frequencies that were unaffected by jamming.

One of the things RFA does to get around jamming is to use frequencies that are not published and to change frequencies. It might seem counterintuitive to shift or move a published frequency, but that's not the case with RFA. The attitude of people in China who listen is, "Not to worry, we will find you."

When I visited Radio Free Asia headquarters in March 2012 one of my questions was, "How can you get listener feedback from, let's say, the Korean Service that targets North Korea?" North Korea is one of the most reclusive states in the world. There is virtually no Internet access to average North Koreans, it's reserved for the elite of the Workers Party. In addition, television, radio and newspapers are all controlled by the government. Televisions and radios available in North Korea are also fix-tuned, intended for reception of official government stations only.

But, North Korea borders China and along this border all kinds of goods are smuggled into the North and sold on the black market, such as unlocked mobile phones that can access the Chinese networks and small shortwave radios. The penalty for owning a shortwave radio in North Korea is arrest. There was one case several years ago where a man and his family were sent to the Hoeryong concentration camp, one of the most notorious labor camps in the country, for listening to shortwave. It's a very risky business.

Those fortunate to leave the country and make their way to South Korea have mentioned they listened to RFA. While North Korea does jam RFA, because of the economic hardships and lack of energy, their jamming is not at all that effective.

A Visit to RFA HQ

RFA's headquarters are located just a short walking distance from Georgetown in Washington, D.C. and, if you didn't know what build-



Exiled Uyghur leader Rebiya Kadeer in Radio Free Asia studio. (Courtesy: RFA)

ing they were in, you could walk right past it. The building looks just like the other office blocks in the area. But once you walk in and get to the correct floor, it's a whole different world. They have approximately 270 full time staff working around the clock in this all-digital facility.

Overseas offices are located in Hong Kong, Taiwan, Thailand, Cambodia, South Korea and India. But at the same time they work with stringers from within places like China who



North Korea defector interviewed on-air in RFA broadcast studio. (Courtesy: RFA)



Special QSL card issued for the 25th Anniversary of the SWL Winter Fest (Courtesy: RFA)



Burmese (4 hours daily)
0030-0130 12115, 15700, 17835
1230-1330 7390, 9335, 13675
1230-1400 7390, 9335, 12140
1400-1430 7390, 9335
1630-1730 9945

Cantonese (2 hours daily)
1400-1430 12135
1430-1500 7280, 12135
2200-2300 11785, 15320

Khmer (2 hours daily)
1230-1330 12140, 15145
2230-2330 5840, 13740

Korean (5 hours daily)
1500-1700 648, 5820, 7210, 7455
1700-1800 648, 5820, 9975
1800-1900 648, 5820, 7465
2100-2200 648, 7460 9385 11945

Lao (2 hours daily)
0000-0100 15545, 15690
1100-1200 9325, 15120

Mandarin (12 hours daily)
0300-0400 13785, 15120, 15615, 15635, 17485, 17855, 21595, 21650
0400-0500 13760, 15615, 15635, 15660, 17615, 17855, 21480, 21580
0500-0600 13760, 15615, 15635, 15660, 17615, 17855, 21580, 21710
0600-0700 13760, 15615, 15635, 17495, 17615, 17855, 21720
1500-1600 9455, 9905, 11540, 11965, 13640, 13675, 15430
1600-1630 5895, 9455, 9905, 11540, 11870, 13675, 15430
1630-1700 5895, 9725, 9905, 11550, 11610, 11870, 13675, 15430
1700-1800 5895, 7280, 9355, 9455, 9540, 9905, 11695, 13780
1800-1900 7280, 7355, 9355, 9455, 9540, 9690, 11540, 13780
1900-2000 1098, 5855, 7260, 7355, 7435, 9355, 9455, 9875, 9905, 11785, 13780
2000-2100 1098, 5855, 6140, 7260, 7355, 7435, 9355, 9455, 9905, 11785
2100-2200 1098, 5855, 6140, 7355, 7435, 9455, 9905
2300-0000 7540, 9535, 11760, 11785, 15430, 15585

Tibetan (10 hours daily)
0100-0200 9680, 9885, 11695, 17505, 17730
0200-0300 9885, 11695, 11745, 17610, 17730
0600-0700 17510, 17765, 21500, 21690
1000-1100 13680, 15435, 17495
1100-1200 7470, 13830, 15670, 17495
1200-1400 7470, 11605, 13795, 13830, 15670
1500-1600 9370, 11585, 11795, 11835
2200-2300 7505, 9815, 9880
2300-2315 7505, 9805, 9815, 9875
2315-2400 7505, 9805, 9875, 9900

Uyghur (2 hours daily)
0100-0130 9350, 9400, 11895, 11945, 17640
0130-0200 9350, 9400, 11895, 11945, 17635
1600-1700 9370, 9555, 9975, 11590

Vietnamese (2.5 hours daily)
0000-0030 7445, 11605, 13730, 15570
1400-1430 1503, 9715, 11605, 12075, 13640
1430-1500 9715, 11605, 12075, 13640
2300-2330 1503
2330-2400 1503, 7520, 11605, 13730, 15570

Radio Free Asia

Created and funded by the U.S. Congress, Radio Free Asia (RFA) began in March 1996. As a surrogate broadcast network, RFA is dedicated to the free flow of accurate, timely, unbiased news, information and commentary that is beamed to Asian countries where such news reports are unavailable. It also aims to promote freedom of opinion and expression, including the freedom to seek, receive, and impart information and ideas through any medium, regardless of frontiers. Mandated to broadcast in Burmese, Cantonese, Khmer, Korean, Lao, Mandarin, Tibetan, Uyghur and Vietnamese, English is spoken only when appropriate.

RFA is headquartered in Washington, DC with offices in Asia and correspondents throughout the world. Please listen to our programs and learn more from our website at www.rfa.org.



The Dalai Lama
1989 Nobel Peace Laureate
January 22, 1997

First RFA QSL card issued. (Courtesy: RFA)

call in with reports. This in itself is risky as the Chinese government sees RFA as an illegal station, so when they do speak to people from within China and other locations, real names are not used and voices are disguised so as not to put in jeopardy the lives of the reporters and their families.

The station falls under the umbrella of the Broadcasting Board of Governors (BBG) that oversees all U.S. international broadcasting including Voice of America, Radio Liberty, and Radio Martí, for example. In the 2013 congressional budget request, RFA gets only five percent of the \$720 million budgeted. That works out to around \$35 million a year.

Recently there was some discussion in the U.S. to cut the Chinese programming from the Voice of America as Radio Free Asia already broadcasts in Chinese. But these two services are different. The mandate of the Voice of America is to provide the viewpoint of the United States government in its international policies. RFA on the other hand provides information and news not reported by the state media outlets in China. The same goes for the other language services as well.

Some of Asia's most important figures for freedom and democracy are regular listeners. They include Burmese democratic leader Aung San Suu Kyi, Chinese artist Ai Weiwei, exiled

Uyghur leader Rebiya Kadeer and the exiled Tibetan spiritual leader, the Dalai Lama, who said, "I listen to Radio Free Asia everyday along with my breakfast." But what is even more touching is the response that comes in from regular listeners.

Among the many who risk retribution from their government for contacting RFA include a listener from North Korea who wrote, "I felt that RFA-Korean became a lighthouse for defectors like me, guiding me to South Korea. I was even listening to the radio when I was arrested, and the police took it away." A high school student from Guangzhou in South China wrote, "Now we high school students are starting to get to know your station. Your program is very educational. You give us information that our teachers and government won't give us."

On a lighter side, Radio Free Asia is also a favorite to SWLs the world over. This is because of the special QSL cards the station issues. Each card is sent out personally and includes the site that was tuned in. In some cases the transmitter site is not mentioned as it is one of the un-published frequencies. To find out more about what they do I would strongly suggest you visit their website. There is a lot of content in English including video and audio. For the latest information on RFA frequencies, go to www.rfa.org/english/about/frequencies.html.

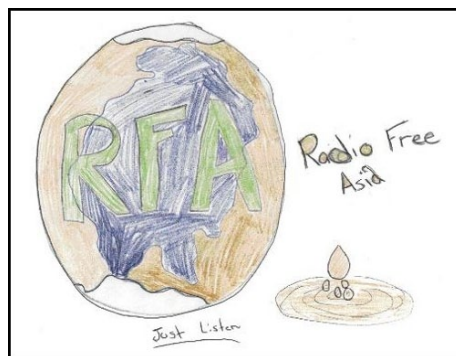

RFA QSL card. (Courtesy: RFA)

Radio Free Asia Frequencies as provided by RFA as of March 25, 2012 (times are UTC). Published frequencies are subject to jamming. You may e-mail your reception report to: qsl@rfa.org. Or you can send it by regular mail to:
Reception Reports
Radio Free Asia
2025 M Street N.W., Suite 300
Washington, D.C. 20036 U.S.A.
For the latest news from Radio Free Asia visit RFA's English website:
www.rfa.org/english

Antennas for Shortwave Listening

Part three of a four part series on antennas

By Bob Grove W8JHD

Before we get mired in the details, let's take a general look at antenna considerations for shortwave listening, the popular, global, high frequency (HF) portion of the radio spectrum. We'll start with the most common choice, the random-length wire antenna.

First of all, because we are going to be tuning through at least a 10:1 change in frequency and thus wavelength, there's no critical, resonant length. That's why such a receiving antenna is known as a "random wire," it isn't calculated for a particular frequency.

Second, since we're going to be receiving signals in the fractional-volt level, any gauge wire will work just fine, so long as it's strong enough to support itself. Stranded wire is more commonly recommended because it flexes better than solid wire in the wind.

Third, a 150 foot wire is no better at receiving than a 50 foot wire. This is because the limiting factor at those frequencies is the combined natural noise from global thunderstorms – static. A longer antenna merely increases the levels of both signals and background noise, so there's no net gain in clarity of reception which is expressed as signal above noise and interference.

Fourth, the higher you can place an antenna, the better. Ground reflections, which make the response favor overhead rather than the horizon, are minimized the higher the wire is erected. And you want that horizontal distance.

Fifth, string it away from your home and power lines. This reduces the level of electrical noise interference from modern appliances and electrical arcing on old power line insulators. Avoid suspending the wire parallel to nearby electrical wiring including power lines.

Sixth, use well-shielded coaxial cable for the transmission line to your receiver. The shielding prevents pickup of electrical noise surrounding it into your home.

And seventh, erect the wire so that its broadside faces the desired target country or countries. Signals aren't being received off the ends of the wire. You can easily determine this direction by stretching a piece of string between your location and the target on a world globe. Don't use a flat paper map – the earth isn't flat no matter what you may have heard!

Popular Wires

Current flux in the world market as well as dealer markups cause pricing to change frequently. The prices quoted below are approximate, given for comparison purposes and



PAR End Fedz (\$75) 45 foot antenna. (Courtesy: Universal Radio)

don't include shipping.

For those listeners who would rather buy a wire antenna ready for installation, the PAR End Fedz 45 foot antenna (\$75) is extremely popular with shortwave listeners (SWLs), reporting rave reviews.



Antenna Supermarket's Eavesdropper dipole antenna (\$105). (Courtesy: Universal Radio)

Another popular favorite is the Eavesdropper SWL Sloper (\$115). If price is a concern, try the Grove FlexTenna (\$15) for continuous 10 kHz-50 MHz reception. It may be hung from a convenient tree limb.

Active Antennas

Because of the generally larger (or at least longer) antennas designed for shortwave, shortening the antenna is often desirable. But how can you do that and still pick up enough signals?

It was determined by a U.S. Coast Guard experiment back in the 1960s that a five-foot whip antenna provided enough signal strength to hear all stations that were in their HF network. And that was without any amplification other than the receiver's own RF stages.

But it is possible for a two or three foot whip to produce signal levels equivalent to those received off a full-size dipole; it's done with an amplifier.

An active antenna refers to any antenna element that is equipped with amplification, often 20-30 dB or so, between its junction and the coax feedline. The power source is often fed

up to the antenna through the coax cable since an elevated antenna is not a good place to have to turn something on and off!

On the plus side, active antennas have wide bandwidth, high signal output, and they are compact. Their disadvantages are that they are relatively expensive; they can't be inexpensively switched on and off to bypass the amplifier for continued reception of unamplified signals; they require power; they are vulnerable to nearby lightning strikes; they add noise of their own; and they produce intermodulation from strong-signal overload.

It would seem that active antennas have more going against them than for them, but the truth is, most of those currently on the market work very satisfactorily for SWLs who can't put up an obtrusive wire antenna.

One of the most popular of these is the affordable LF Engineering H-800 (\$150) with 10 kHz – 50 MHz applications. A follow-on model, the H-900 (\$190), offers slightly higher gain and dynamic range with frequency coverage up to 60 MHz. An untuned, amplified model from Kaito, their KA35 (\$90), uses ultra-compact ferrite rod construction and covers 100 kHz-30 MHz.

MFJ makes several active antenna models



LF Engineering's H-800 (\$150) Sky-Match active antenna. (Courtesy: Universal Radio)



Kaito KA35 (\$90) active antenna. (Courtesy: Kaito U.S.A.)

such as the long-time favorite MFJ-1020C (\$90). It doubles as an indoor active antenna or tunable amplified preselector when used with an outdoor antenna.

Loop Antennas

Besides the amplified active variety, compact receiving antennas for shortwave also come in large and small open loops and ferrite rod loops which may be mounted indoors or outdoors, depending upon their construction. But the most common are small indoor models.



AOR LA-390 (\$420) active loop antenna. (Courtesy: AOR U.S.A.)

Once we discount the obvious disadvantage of an indoor loop being so close to electrical interference sources, they do offer a number of advantages over a simple room-strung wire, or even the short whip on a multiband portable.

Loops can be positioned and easily swiveled to minimize interference and/or favor reception of specific signals. Most of them can be tuned to specific frequencies, thus reducing strong-signal overload from off-frequency signals.

Some loops offer very wideband operation like the AOR LA-390 (\$420) with its 10 kHz-500 MHz frequency coverage. The AOR is actually a hybrid of an amplified tunable loop on frequencies below 30 MHz and an active antenna for VHF/UHF reception.

Worthy of mention in spite of cost plus ship-



Wellbrook Communications large aperture active loop antennas about \$240. (Courtesy: Wellbrook Communications)

ping to North America are the British Wellbrook large aperture active loop antennas at about \$240.

When shopping for a loop antenna, pay attention to the intended frequency coverage. There are loop antennas on the market with only AM broadcast band applications (530-1700 kHz).

Balun Transformers

Although not necessary for good reception, many purists want to be sure they properly match their feedline impedance to their antennas. Since dipoles are considered balanced antennas and coax cable is an unbalanced line, balun (balanced to unbalanced) transformers are frequently used to accomplish both specifications.



Palomar Engineers 4:1 balun kit (\$32). (Courtesy: Palomar Engineers)

A primary advantage of a balun is to provide symmetry and thus predictability in the reception pattern (and transmission if used for that purpose), but it must be remembered that patterns change with frequency.

Baluns are very broadband by nature and can be easily made by winding a few turns of wire through a ferrite toroid. They can also be purchased as an easy kit, or bought fully assembled with connectors ready to install on the antenna).

Multiband Portables

Multiband portable radios are made for global distribution, so they often include low frequency (LF) coverage down to 200 kHz, medium frequency (MF) coverage of the AM broadcast band up to at least 1700 kHz, high frequency (shortwave, HF) up to 30 MHz, and FM broadcast as well, typically 87.5-108 MHz.

It must be accepted that shortwave portable



Sangean 909X (\$260) portable shortwave receiver. (Courtesy: Sangean U.S.A)

radios are not the finest receiving instruments on the market. Their singular purpose in life is portability. As such, they usually suffer from poor adjacent-channel selectivity and front-end overload from strong signals and are priced accordingly.

A long-standing favorite multiband portable because of its performance and affordability is the Sangean 909X (\$260) like many portables has a jack for an external antenna.

Although portables are battery operated, so they can be moved around or even carried to outdoor activities, they are most often operated indoors. This makes them vulnerable to electrical and electronic noise from household wiring and environmental electronic accessories, especially from those devices which contain microprocessors. A growing noise source is the switching-type power supply which radiates harmonic noise well into the shortwave frequencies. The older, husky wall warts with transformers are quiet.

To avoid the electrical interference assault, having an outdoor antenna is a distinct advantage, although the front-end overload vulnerability will be exacerbated by the stronger received signals.

Some models of shortwave portables like the Sangean model cited above come with reel antennas, 10 to 30 feet of flexible, insulated wire spooled in a small capsule which can be extended in the listener's room. A plug is included for connection to the radio's external antenna jack, thus disconnecting the radio's telescoping whip antenna.

While reel antennas do, indeed, increase the radio's pickup of weak stations, it must be remembered that since they are intended for indoor use, they pick up environmental electrical noise as well. There is no substitute for an outdoor antenna.

Tuners

Several manufacturers offer tuners, more correctly called preselectors, for receivers. These devices can provide very sharp selection of the desired signal while attenuating adjacent signals above and below that frequency. An example is the MFJ-956 (\$70).



MFJ-956 (\$70) preselector. (Courtesy: MFJ Enterprises)

Preselectors are considerably different from amateur radio antenna tuners (also known as transmatches) in that the former select a particular frequency, while the transmatch simply makes sure the impedance of the antenna line is close to that of the receiver.

Preamplifiers

We've listed the caveats against boosting shortwave signals since some of them are already very strong, and receiver front-end overload produces many negative characteristics such as desensitization, intermodulation, and images, all of which tend to reduce rather than enhance reception. But there are fixes.



Ramsey 1678 1-1000 MHz wideband preamplifier (\$60). (Courtesy: Grove Enterprises)

One solution to this is to insert a variable attenuator, essentially an adjustable resistor, between the output of the preamplifier and the receiver's antenna jack. It can be adjusted to reduce the amplified signal low enough to avoid overloading the receiver, while still boosting signal strength.



Inexpensive signal attenuator (\$12-20) limits signal overload. (Courtesy: Antennas Direct)

Such attenuators are available at low cost from department stores that sell TV accessories. A typical \$20 example is shown above.

Preamps often come with narrow frequency range, best suited for VHF/UHF reception, but one of the most popular is the wideband 1-1000 MHz Ramsey 1678 (\$60).

But preamplifiers with preselection are another matter. Most are equipped with gain controls to avoid over-amplification, and the sharp tuning of the preselector homes in on one very narrow part of spectrum in order to boost only those weak signals. An example of such a useful accessory is the MFJ-1046 (\$120).

Of course if you already have a tuner (pre-



MFJ-1046 (\$120) antenna preamplifier/preselector. (Courtesy: MFJ Enterprises)



Icom R75 (\$750) typical new receiver with built-in Digital Signal Processing. (Courtesy: Universal Radio)

selector), then you can simply add a wideband preamp and let the preselector choose the small signal swaths that you desire to amplify.

Noise Sources

In our modern electronic age it's no wonder that electrical/electronic interference surrounds us. Power lines arcing, computers, microprocessor-controlled appliances, Broadband Over Power lines (BPL), switched-capacitance power supplies, plasma TV sets and other emitters of interference can pollute the radio spectrum you're trying to hear.

In the early days of mobile radio, only spark ignition noise and alternator whine gave us a problem, but now with computerized ignition systems, there is a spectrum of hurt awaiting mobile radio enthusiasts.

In reality, the majority of these noises dissipate the higher in frequency we tune, but the bad news is that much of it is still present well into the shortwave spectrum. And if you happen to live in an apartment complex, my condolences!

Noise Cancellers

But not all is lost just because you are surrounded by electrical noise generators. There are measures that can be taken to reduce such annoyances. Ideally, of course, your antenna should be outdoors and away from buildings and power lines. That's the first measure for noise interference reduction.

But modern receivers have been designed to cope. Automatic noise limiters are the oldest countermeasure for electrical noise, and they still work. Noise blankers work by momentarily turning off the receiver when a noise pulse is detected; it happens so fast that you hardly notice it.

Digital signal processing (DSP) is more sophisticated, converting the received analog signal into digital bits so that the noise portion can be se-

lectively removed. DSP is now commonly found on modern transceivers and communications receivers such as the popular ICOM R75 (\$750) and the high end R9500 (\$13,300).

Another interesting device is an accessory product descriptively known as a noise canceller. It works by using two antennas. One, the signal antenna, and the other, called a noise antenna.

Since the noise arrives at different times at the two antennas, their relative phase angles may be compared and subtracted from an adjacent portion of the spectrum while not affecting the frequency to which you are listening. The Timewave ANC-4 (\$200) is an excellent example of such a device. **MT**

WWW.SCANCAT.COM

TOLL FREE 888-722-6228

ScanCat-Lite-PLUS

Reg. \$39.95 - Limited Time Special \$29.95

Now It's Easier Than Ever To Program Your Scanner.

FREE walk-you-through set up videos.

www.scancat.com

Click on "Learn as you view." **You Tube**

ScanCat-Lite-PLUS

- Supports over 50 scanners in our one single program

- Import One Scanner's frequencies, Program any other radio scanner with the same frequencies

COMBO ALL-IN-ONE CD

ScanCat-Lite-Plus.....\$29.95

Mr. Scanner FCC Public Safety\$29.95

Nat-Com's FCC Scancat Files\$9.95

Bonus Disk Of Frequencies.....\$15.00

If Purchased Separately \$84.85

NOW \$49.95

Plus \$6 s&h

PLUS FREE Scanning Magazine(s)

(With Any Order Over \$40.00)

NOW AVAILABLE \$CALL HOKA Code 3-32



COMPUTER AIDED TECHNOLOGIES

ORDERS: (318) 687-4444 FAX: (318) 686-0449

Info/Tech Support: (318) 686-1999

(9 a.m. - 3 p.m. Central M-F)

WWW.SCANCAT.COM



Timewave ANC-4 (\$200) noise canceller. (Courtesy: Timewave)

Shortwave Listening: The State of the Industry

By Ken Reitz KS4ZR

The combination of a poorly performing global economy, drastic national budget cuts around the world and increased expansion of Internet connectivity, have combined to send international shortwave broadcasting into a worldwide tailspin. That's the common wisdom, but all of this is happening at a time when technology has also brought unparalleled capability in the latest shortwave receivers and a growing awareness of the flaws in an all-Internet broadcasting future. It also comes at a time when the industry is desperate to promote Digital Radio Mondiale, the long-promised engineering scheme to bring better audio to the shortwave bands through digital broadcasting.

To help determine the real state of the current world of shortwave broadcasting and listening, I asked four of the industry's most keen observers their opinion on a number of issues regarding the industry today. The panel includes Bob Grove, Publisher of this magazine and Founder of Grove Enterprises; Fred Osterman, President of Universal Radio, which has been offering shortwave listening equipment for more than 60 years; Keith Perron, longtime international shortwave broadcaster and Jeff White, Founder and General Manager of WRMI, Radio Miami International.

MT talks to Jeff White:

Your involvement in shortwave broadcasting, particularly to Latin America, goes back decades. How does the shortwave listening audience in Latin America today compare with the rest of the world; Europe, Africa, and Asia?

Jeff White:

Of course no one has any good statistics, but I think certainly the Latin American shortwave audience remains more robust than in places such as North America and Europe. And, the Latin American audience is younger than that in North America and Europe. A lot of young people are still just discovering shortwave, though it's not as widespread as in Africa by any means.

MT: Are Latin American listeners switching to online listening instead of shortwave radio? If they are switching, is it because the stations they want to hear are no longer broadcasting on the air, but online?

Jeff White:

I don't have the impression that there are very many Latin American listeners who are listening to international radio stations online, at least not in comparison with listeners in North America, Europe and parts of Asia. The ones who do listen online are probably doing so for convenience and better audio quality, rather than because a station has gone off the air and is only online.

An extremely large percentage of Latin American listeners do not even have Internet access in their homes, let alone a service that is fast enough for online radio station streams. They might have fast Internet access at their place of employment, university, or an Internet cafe, but these are not generally appropriate locations for listening to online radio streams. Those who do have Internet access in their homes often have very slow speeds (like 750 kbps which I found in my sister-in-law's home in Venezuela), and these can be problematic for listening to radio station streams.

The reason for the lack of high-speed Internet service in homes in Latin America is often a combination of inadequate infrastructure, such as the kind of extensive cable-TV penetration enjoyed by U.S. consumers, and the inability of people to afford the relatively high costs of fast services where they are available. Frequent power outages are also a serious problem in many Latin American countries.

MT: Shortwave broadcasting in South America has traditionally been a regional necessity because of the great

distances needed to cover. Is that still the case or are local shortwave entities going online as well?

Jeff White:

Domestic shortwave broadcasting (mostly on the tropical bands) has been gradually phased out in most of Latin America over the past few decades. There is little left except in places like Peru, Bolivia and Brazil, where it is still very common. Other than these three countries, domestic stations, which used to have shortwave frequencies, have largely replaced shortwave with other alternatives such as local FM relays and, yes, to some extent, online streaming, although as I mentioned earlier, Internet access is rather limited, especially in remote areas where the shortwave was mainly listened to.

Online listening, when it is happening, would be mainly in large cities where the stations can usually be heard on AM or FM frequencies anyway. There are still a few domestic shortwave stations in countries such as Guatemala, Ecuador, Colombia, Cuba and Guyana. Some of these are religious stations. A lot of domestic stations in Latin America which previously had shortwave frequencies have abandoned these due to the increased costs of electricity and maintenance of old transmitters and the relatively small commercial importance of their shortwave audiences to them.

MT talks to Keith Perron:

MT: The latest technology in shortwave listening is Software Defined Radio (SDR). Do you see this technology, with its ability to tune analog as well as DRM shortwave broadcasts as helping rejuvenate shortwave listening? Secondly, if DRM is to become a dominate player in international broadcasting, what has to happen?

Keith Perron:

In North America, Europe and other areas of the world where there is good access to Internet and satellite television, I don't think DRM would make any difference. In areas



WiNRADiO G305E (\$900) offers 9 kHz to 1800 MHz coverage in a PC-based receiver. (Courtesy: Grove Enterprises)



AOR AR5001D (\$4,500) top-grade, wideband receiver takes you anywhere in the spectrum you'd like to go from 40 kHz to 4150 MHz. (Courtesy: AOR U.S.A.)

where shortwave still has a large audience it might help if it's made accessible. But, once a station leaves shortwave they have no relevance. If we take Radio Canada International, for example, which only left the bands a few weeks ago, there's no point to them having an Internet presence, because anything they have on the site now, you can get from the CBC site. There is just no reason for the duplication.

Radio Netherlands left shortwave with a change in mandate to target countries that have no press freedom. When I spoke to the director general of Radio Netherlands Worldwide (RNW) and asked him how they intend to reach an audience, let's say, in China, if the Chinese decide to block the RNW site because of the change in policy; how will people hear the programs they are trying to put online? He didn't give an answer. Personally, I predict that RNW will be gone totally within the next five to six years.

MT: Where is the largest audience for shortwave listening: Asia, Africa or South America?

Keith Perron:

The largest shortwave audiences are in Africa, Southeast Asia, parts of East Asia, Latin America and the Pacific. Asia is an interesting area. If we take Singapore, for example, with a population of four million, I think there is only one shortwave listener and that's when I'm in Singapore; same goes for Taiwan. But in Malaysia, Sri Lanka, India, Bangladesh, Indonesia and other places, there are huge shortwave audiences.

MT: What price point would you suggest manufacturers shoot for to make DRM-capable receivers a popular purchase?

Keith Perron:

If 15 years ago manufactures had come out with a DRM receiver that was around \$70U.S., it might have had a chance. But so far the radios are either expensive or poor quality. Some companies like Sangean did toy around with DRM a few years ago, but decided to drop it. What's the point in making a receiver if there is no programming? Here's the problem; there is no content worth listening to. But then it leads to, "Why should we have programming on DRM if there are no receivers and less than 100 people listen?"

MT Talks with Bob Grove and Fred Osterman:

MT: Despite the migration of traditional international broadcasters from shortwave to online, new Software Defined Radios, known as SDRs, seem to be breathing new life into the shortwave listening hobby, particularly utility listening. As long-time national retailers of shortwave radios, have you seen a shift in the purchasing habits of SWLers?

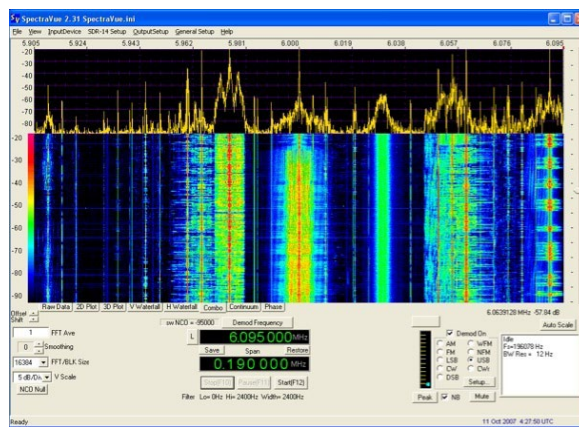

RFSpace SDR-IQ (\$500) spectrum display. (Courtesy: Universal Radio)

Bob Grove:

Initially, SDRs were received coolly by the listening public who had been brought up on analog receivers. But, with the advent of computer-controlled everything, and more manufacturers offering SDRs with remarkable features and specifications, we find more and more interest in them.

Fred Osterman:

Clearly the action and innovation on the top end of the HF receiver market falls to the SDRs. I think there are two reasons for this. First, SDRs simply have more capabilities (spectrum display, storage of spectrum, etc.) than conventional sets. And, their performance is also on-par or superior to high-end traditional receivers. The second reason they have taken over the high-end HF receiver market is because there are virtually no new high-end conventional sets coming to market. Regrettably, many former shortwave manufacturers have left the high-end shortwave receiver market because they perceive the hobby market to now be too small. I find that the government market is increasingly looking to SDRs, and other computer controlled radios, for automated or semi-automated monitoring.

MT: How do SDR sales compare with traditional desk-top sets in similar price ranges?

Bob Grove:

Not much has changed in this respect. The Sangean 909X, Grundig G3, and Kaito KA-1103 are our best selling portables while the Icom

R75 still leads in desktop receivers sold to consumers. The WiNRADiO G315 and their new line of G3 models sell very well. Icom's R2500 is a hot seller in spurts to the professional and government market.

MT: SDRs currently require fairly robust computers to work well. Will we ever get to a place where an SDR can be run on an iPad?

Bob Grove:

Yes, in fact simple applications are available right now for iPads and iPhones. Apple is finicky about what apps are in their stores, but Androids are quite open. This is a natural evolution in electronics, and it's inevitable.

Fred Osterman:

It's true that SDRs do require high horsepower PCs but, fortunately such PCs are increasingly affordable and many mid-priced notebooks work well too.

MT: DRM seems to have slowed to a snail's pace. While it is developing more rapidly in Europe and India, will North American SWLers ever benefit from such reception?

Bob Grove:

I'm somewhat skeptical about the future of DRM. Even now, it's difficult to find DRM stations on the air, and not all of them can be heard successfully due to interference and QSB (signal flutter and fade). Under the same austere conditions, traditional AM shortwave broadcasters can still be heard with proper filtering such as digital signal processing (DSP), for example.

Fred Osterman:

I agree, DRM is developing at a slow but steady pace in Europe and there seems to be a really strong push for it in India. Elsewhere, it is at a snail's pace. DRM does seem suitable for regional shortwave broadcasting, but as you know, it becomes less consistent over inter-continental distances, at least with the current, small crop of DRM receivers. Most of the dedicated DRM receivers I have used to date seem to be designed by "digital" people, rather than "RF" people. Their ergonomics and receive performance is only marginal for North American users. Still, I remain optimistic that some supplier will develop a listener-friendly, affordable, portable DRM radio with the performance level we need in North America.

MT Wants to Hear from You

What are your own experiences with DRM reception and SDRs? Have you recently purchased an SDR and, if so, how has that changed your shortwave listening hobby? What are your own hopes for the future of international broadcasting and shortwave listening in general? Send your comments to editor@monitoringtimes.com.

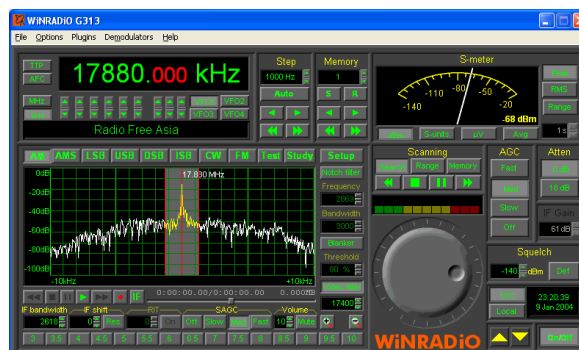

WiNRADiO G313e spectrum display. (Courtesy: Grove Enterprises)

So many options!

Alinco



GRE

Uniden



Bob's Bargain Bin is a great source for all of your used/discontinued radio needs. If you're in the market for another radio, then call or email Grove and see what kind of deal we can offer!

GRO

AOR

Grundig

MFJ



WINRADIO



Icom

LF Engineering

GROVE

Crane

Grove also offers the latest and greatest technology in the radio world! Not only do we offer amazingly competitive pricing, but we also have the absolute BEST service in the business.



All from Grove!

PAR

800-438-8155

828-837-9200 fax: 828-837-2216

WWW.GROVE-ENT.COM



SCANNING REPORT

THE WORLD ABOVE 30MHZ

Dan Veeneman

danveeneman@monitoringtimes.com

www.signalharbor.com

Coping with Old and New Systems Where You Live

In this election season we are reminded that politics seems to affect nearly every facet of our lives, including scanning. This month we take a look at a new system scheduled to come on-line in Pennsylvania and how a new law is causing headaches before it is even operational. But first, let's answer some questions from a new hobbyist.

❖ Pennsylvania

Hi Dan,

I checked out your page (signalharbor.com), and that is a wealth of information! I'm really excited because I found a link to the U.S. frequency allocation chart. I've been looking for one of those for years.

Anyway, I want to purchase a handheld scanner but am not confident enough in what I have learned so far about scanners to plunk my money down yet. I want to buy the proper one for my area. I was wondering if I could get your insight on what I need for my area. I think it will be a conventional radio; not certain if I need trunking. I also believe that the state police have gone to OpenSky. I cannot receive that, right? I live in Waynesboro, Pennsylvania and would like to receive in about a 10-mile radius. I'd like to keep the cost down and just get what I need, but I also realize that as systems get more complex or if I travel with it I may be glad I bought a more sophisticated radio. Also, tell me about programming software. I don't understand why I need this or what I'd need to buy.

Thanks so much!
Bill in Pennsylvania

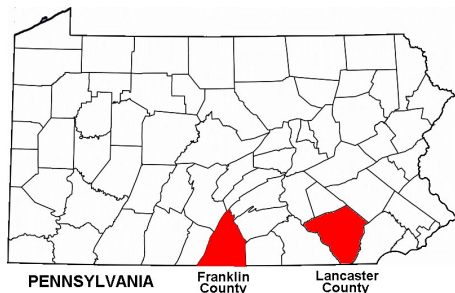

Waynesboro is located just north of the Maryland State line, about 70 miles northwest of Baltimore. It is home to about 10,000 residents and is located in the southeast corner of Franklin County. The United States Government facility known as Raven Rock Mountain Complex (RRMC) ("Site-R"), a military communications

facility and emergency operations center, is only a few miles east of Waynesboro. Franklin County itself has about 150,000 people and covers an area of more than 700 square miles, including the Letterkenny Army Depot.

There are some analog radio systems operating in the county that can be monitored with nearly any scanner, so a basic unit is more than sufficient to hear the following activity.

Frequency Description

45.62	Countywide Police (Dispatch)
46.10	County Fireground (North)
46.16	County Fire (Dispatch)
46.24	County Fire Police
46.36	County Fireground (South)
149.6000	Site-R Military Police ("Hawkeye")
158.1750	Allegheny Power
165.0125	Letterkenny Army Depot (Security)
165.1875	Letterkenny Army Depot (Operations)
173.4875	Letterkenny Army Depot (Operations)
453.0750	County Fire (Dispatch) (Simulcast of 46.16)
453.3750	County Jail (Operations)
453.4875	County Fire Operations 1
453.5500	County Fire Operations 2
453.8500	Greencastle Police (Dispatch)
460.0250	County Sheriff
460.0500	County Fire Police
460.1250	County District Attorney's Office (Narcotics)
460.3750	Chambersburg Police (Dispatch)
460.4500	Chambersburg Police (Encryption reported)
460.5000	Chambersburg Police
460.5250	Waynesboro Police (Dispatch)
460.5500	Countywide Police (Dispatch)
460.6250	Greencastle Rescue Hose Company No 1
461.4750	Waynesboro Ambulance Squad
462.9750	County EMS (Dispatch)
463.0000	EMS-to-Hospital (Med 1)
463.0250	EMS-to-Hospital (Med 2)
463.0500	EMS-to-Hospital (Med 3)
463.0750	EMS-to-Hospital (Statewide)
463.1000	EMS-to-Hospital (Med 5)
463.1250	EMS-to-Hospital (Med 6)
463.1500	EMS-to-Hospital (Med 7)
463.1750	EMS-to-Hospital (Med 8)
463.9000	Blue Ridge Mountain Ambulance

Franklin County also operates a trunked APCO Project 25 (P25) system using two sets of frequencies. The first set, specifically 494.5750, 494.7875, 495.0125, 495.2500, 495.4500 and 495.6000 MHz, are transmitted from six locations around the county: Chambersburg, McConellsburg, Mercersburg, Roxbury, Scotland and Upper Strasburg.

The second set of frequencies, 494.3375, 494.5000, 494.9375, 495.2000, 495.4625 and 495.8625 MHz, are actually transmitted from Quirauk Mountain, located near Fort Ritchie just across the border in Maryland. Some of the active talkgroups on the system are listed below.

Decimal	Hex	Description
10	00A	County Police (Dispatch)
11	00B	County Police
13	00D	County Police
14	00E	County Police
15	00F	County Police
16	010	County Police (Tactical 1)
17	011	County Police (Tactical 2)
26	01A	County Sheriff
21	015	Chambersburg Police (Dispatch)
22	016	Chambersburg Police
29	01D	Chambersburg Police
31	01F	Greencastle Police
32	020	Washington Township Police
33	021	Waynesboro Police
34	022	Mercersburg Police
100	064	County Fire (Dispatch)
101	065	County Fire
102	066	County Fire
103	067	County Fire
104	068	County Fire
105	069	County Fire
106	06A	County Fire
107	06B	County Fire
108	06C	County Fire
109	06D	County Emergency Medical Services
110	06E	County Emergency Medical Services
111	06F	Fire Police (Dispatch)
112	070	Fire Police
113	071	Fire Police
114	072	Chambersburg Fire
115	073	Waynesboro Fire
116	074	Rescue Hose Company
117	075	Blue Ridge Mountain Fire
118	076	Mont Alto Fire
120	078	Fayetteville Fire
121	079	Marion Fire
122	07A	Mercersburg, Montgomery, Peters Warren (MMPW) Fire
123	07B	County Air Unit
124	07C	Pleasant Hall Fire
125	07D	Fannett-Metal Fire
126	07E	Letterkenny Army Depot Fire
127	07F	Friendship Fire
128	080	West End Fire
129	081	South Mountain Fire
130	082	New Franklin Fire
131	083	Saint Thomas Fire
133	085	Metal Township Fire
134	086	Franklin Fire (Station 4)
201	0C9	Ambulances to Chambersburg Hospital

202	OCA	Ambulances to Waynesboro Hospital
322	142	County Department of Emergency Services
300	12C	Antrim Township Public Works
301	12D	Fannett Township Public Works
302	12E	Greene Township Public Works
303	12F	Guilford Township Public Works
304	130	Hamilton Township Public Works
305	131	Letterk Township Public Works
306	132	Lurgan Township Public Works
307	133	Metal Township Public Works
308	134	Montgomery Township Public Works
400	190	Public Safety 1
404	194	Special Events 1
405	195	Special Events 2
406	196	Special Events 3
407	197	Special Events 4
408	198	Public Works (Common)
411	198	County Transportation Department

❖ Choosing a Scanner

The Franklin County P25 system is completely digital, meaning that all voice activity follows the P25 standard, called the Common Air Interface (CAI). This means that a basic analog scanner will not be able to monitor the system; you will need a digital-capable unit.

Data carried on the control channels also conforms to the P25 trunking standard, so a few of the first generation digital scanners that can only track the older Motorola 3600-baud control channel will not follow conversations on this type of system.

All of this means that you will need a more recent digital-capable scanner to capture all of the action in the county. Some scanners that will work on the Franklin County system and other "pure" P25 networks include:

Make	Model	Type
GRE	PSR-500	Handheld
GRE	PSR-600	Base/Mobile
GRE	PSR-800	Handheld
Radio Shack	PRO-18	Handheld
Radio Shack	PRO-106	Handheld
Radio Shack	PRO-197	Base/Mobile
Uniden	BCD396T	Handheld
Uniden	BCD396XT	Handheld
Uniden	BCD996T	Base/Mobile
Uniden	BCD996XT	Base/Mobile
Uniden	HomePatrol-1	Base/Mobile

Pennsylvania's statewide public safety radio network, called STARnet, is indeed an OpenSky system, which puts it out of reach for listeners since no consumer scanner can track or monitor OpenSky transmissions. So far STARnet has cost about \$368 million to install and operate, with about 200 repeater sites operating in the 800 MHz band.

Programming a scanner has long been a challenge, especially to monitor systems with a large number of frequencies. It used to mean a significant investment in time to tediously enter each and every frequency via the front keypad. However, there are now some technological solutions that make this process much easier.

One of the first improvements in the programming process was the use of a computer interface port and the appropriate software.



Each scanner model uses a specific data protocol on the interface port, requiring you to use a compatible software program to communicate with the scanner. Some scanners come with basic software that allows you to perform simple tasks like frequency loading and editing. However, if the basic software does not provide all of the features and functions you'd like,

there are usually third-party programs that are able to do much more. The appropriate Internet-based discussion group can usually point you in the right direction (see below).

The computer interface port is also needed to perform upgrades to the firmware inside the scanner. Every so often the manufacturer will come out with a new version of the instructions that control the scanner's

internal processor, correcting problems and enhancing performance. These new firmware versions can be downloaded from the manufacturer's web site and installed in the scanner via the interface port.

Another labor saving feature of many newer digital scanners is a "control channel only" capability that allows the unit to track voice activity after programming just the control channel frequencies. Such scanners use information carried in the control itself to properly tune to whatever voice frequency is currently active.

If you'd like to avoid keypad programming altogether, you could choose one of the newest scanners that comes pre-programmed with nearly all U.S. radio systems and has a simple user interface. These models include:

Source	Model	Type	Year
GRE	PSR-800	Handheld	2011
Radio Shack	PRO-18	Handheld	2011
Uniden	HomePatrol-1	Base/Mobile	2010

Once you have a particular scanner in mind, it's probably worthwhile to join an interest group dedicated to that model. For instance, the GRE PSR-800 has a discussion group at groups.yahoo.com/group/PSR-800/ with more than 500 members. Here you can find messages, documentation, data files and software that work with the PSR-800 and can be explained by other users. Such help is invaluable to answer questions and resolve problems.

❖ Lancaster, Pennsylvania

In August, Lancaster County's long struggle to replace their 30-year-old radio technology took a significant step forward when the Board of Commissioners approved a \$20 million with Annapolis, Maryland-based ARINC Incorporated to supply a new public safety radio system.



PA-STARNET

Lancaster County is located in southeastern Pennsylvania and covers nearly 1,000 square miles, half of which is zoned for agricultural use. Much of the area is known as Pennsylvania Dutch country, with Amish and Mennonite farms and local stores.

Public safety in the County has been using a 1960s-era VHF system. It is overcrowded, often leaving users to wait for an unused channel. It suffers from multiple "dead spots" within the county where radio signals fail to reach a repeater site and thus put the user out of reach of a dispatcher. A mix of equipment and frequencies also make it difficult for the more than 120 different departments and agencies within the county to communicate directly with each other.

The County spent eleven years and \$14 million dollars attempting to implement an OpenSky system in the 800 MHz band. After a seemingly endless series of problems and delays, in 2008 the County finally pulled the plug and backed out of the OpenSky contract.

In February 2011, after repeated bureaucratic delays, the Federal Communications Commission (FCC) finally granted Lancaster County's request for frequencies in the recently opened T-Band. It took three years and the

GRE PSR-500

- » Intuitive "Object Oriented" User Interface Design
- » Menu Driven Programming with Context Sensitive Help
- » Upgradeable CPU and DSP Firmware -- You can easily keep your scanner current with software enhancements as they become available with free upgrades from GRE America.
- » Flexible Free-Form Memory Organization
- » GRE's Exclusive V-Scanner Technology
- » Multi-System Trunking
- » P25 NAC Functionality
- » Audible alarms
- » GRE's Exclusive Automatic Adaptive Digital Tracking
- » Spectrum Sweeper
- » Real-time Signal Strength Indicator

Order SCN18

\$389.95

plus \$19.95 UPS Ground Shipping

800-438-8155

828-837-9200

fax: 828-837-2216

WWW.GROVE-ENT.COM

intervention of their Congressional Representative to get the FCC to take action.

The new system operating in T-Band should have better propagation than 800 MHz and will cost less. The County plans to use the repeater sites that were originally built for the OpenSky system and is expecting the new ARINC system to provide improved geographic coverage and higher capacity compared to the current radio equipment. The Lancaster County-Wide Communications (LCWC) currently handles nearly 400,000 emergency calls in a year from a population of half a million residents.

In the near term, ARINC will implement a three-site pilot system in downtown Lancaster City to prove out the new technology and provide a test bed for various radio equipment manufacturers. The agreement with ARINC includes an arrangement where the County will lease the radio equipment rather than purchase it outright. The LCWC expects leasing to be cheaper than buying and allows them to upgrade the system without having to continually purchase new hardware.

The ARINC system will use APCO Project 25 digital standards and operate as a trunked system. The adjacent counties of Dauphin and York are already operating their own UHF T-Band trunked systems and Lebanon County is using UHF trunked radio equipment. The expectation is that such similarities will make interoperability and mutual aid much easier.

❖ T-Band

The T-Band (“Television Band”) is the spectrum between 470 and 512 MHz where UHF television channels 14 through 20 are located. In geographic areas where the radio spectrum is crowded, typically highly populated urban areas, the FCC allocated portions of unused television frequencies to land mobile users, including public safety agencies, on a shared basis with broadcasters. To date the FCC has issued more than 800 licenses to public safety agencies in this band.

This year the U.S. Congress passed a law known as the “Middle Class Tax Relief and Job Creation Act of 2012.” The good news for public safety in this law is the allocation of dedicated spectrum in the 700 MHz band and the promise of \$700 billion in federal funding to build out what is expected to become a nationwide two-way radio network. The bad news is that the law includes a provision requiring the FCC to “reallocate the spectrum in the 470 to 512 MHz band (T-Band) currently used by public safety eligibles” and “begin a system of competitive bidding ... to grant new initial licenses for the use of the spectrum.” What this means is that Congress wants to auction off T-Band frequencies to the highest bidder and force public safety agencies currently operating in the band to move to some other part of the spectrum. According to the law, these auctions must take place within nine years and the resulting relocations must be completed within two years after the end of the auctions.

Although the law specifies that some of the auction proceeds may be used to relocate

current spectrum users, it is not clear at this time whether that will be enough money or how the additional costs of moving will be covered. The FCC is still in the process of working out specific rules and procedures for relocation, so things may change as the deadline nears.

For Lancaster County, as things stand right now they will need to be out of the T-Band no later than 2023. By that time there may be a sufficient number of unused frequencies in VHF or UHF to support their operations, or they might choose to go up to the 700 MHz band. Although radio signal propagation is typically worse the higher in frequencies, the County has already paid for several new repeater sites for their unsuccessful OpenSky system, so coverage at 700 MHz might not be as much of an issue as it would be for other systems.

In the meantime, there are a lot of conventional (non-trunked) analog transmissions to check out. Nearly any scanner manufactured in the last 30 years is capable of monitoring these departments.

Frequency Description

33.08	Manheim Township Ambulance
33.42	Hope Fire Engine and Hose Company
33.44	Local Fire Departments (Shared)
33.46	County Fire Police
33.48	Local Fire Departments (Shared)
33.50	County Fire Police
33.52	Local Fire Departments (Shared)
33.56	County Fireground (Northeast)
33.60	County Fireground
33.62	Hope Fire Engine and Hose Company
33.64	County Fireground (Northwest)
33.68	County Fireground (Metro)
33.72	County Fireground (South and East)
33.76	County Fireground
33.80	Lititz Fire
33.82	Lancaster City Fire (Dispatch)
33.84	Ephrata Pioneer Fire
33.90	County Fire and Emergency Medical Services (Dispatch)
33.92	East Lampeter Township Fire
33.96	Lititz Fire
33.98	Elizabethtown Fire
45.04	Mount Joy Township Fire
45.64	Akron Police
45.70	West Earl
150.9950	Mountville Borough
151.0850	West Lampeter
151.2050	New Holland Borough Police
153.7850	New Holland Borough
154.0025	Fivepointville Ambulance
154.0250	Ephrata Township Police
154.0550	Constables (Dispatch)
154.1000	West Hempfield Township Police
154.2800	Pennsylvania/Maryland Interoperability
154.5700	Constables
154.8000	County Police (Lancaster City)
154.8450	Ephrata Borough
154.8600	County Police (Dispatch South)
154.8750	County Police (Lancaster City)
154.8900	Ephrata Borough Police
154.9650	Manheim Township
154.9800	Canervon Township Police
155.0850	Rapho Township
155.1000	East Earl Police
155.1300	Columbia Police
155.1450	Mount Joy Township and Denver/Cocalico Police

155.1600	Wilderness Emergency Strike Team (WEST)
155.3100	East Cocalico Police
155.3400	Lancaster Emergency Medical Services
155.4075	Lancaster Emergency Medical Services
155.4300	County Police (Dispatch Metro)
155.4900	County Jail (Maintenance)
155.5200	Elizabethtown Police
155.5350	County Police (Dispatch Northeast)
155.5950	East Lampeter Police
155.6400	County Police (Dispatch Northwest)
155.6550	Manheim Township Police
155.6850	County Police (Dispatch East)
155.7150	Millersville Police
155.7450	Lancaster Airport Police
155.7750	Warwick Police
155.8800	East Hempfield and Manor Township Police
155.8950	County Police (Emergency Management)
155.9250	Warwick Township Police
155.9550	Bart Township Police
156.0150	Penn Township Police
156.0300	County Jail
156.1200	Pequea Township
156.2400	Susquehanna Regional Police
157.5975	Fivepointville Ambulance
158.7450	Mount Joy Township
158.8050	West Donegal
158.9550	Manheim Borough Police
159.1050	Youth Intervention Center
159.2250	County Park Rangers
451.8625	Lancaster General Health (Emergency)
451.9125	Lancaster General Health (Buses)
452.1750	Lancaster General Health
452.2375	James Street Improvement District
452.7000	Lancaster General Health (Maintenance)
460.4375	Mount Gretna Fire
461.0500	Lancaster Regional Medical Center (Channel 1)
461.3250	Ephrata Community Hospital
461.4625	Lancaster General Health
461.6375	Lancaster General Health (Food Service)
462.0625	Heart of Lancaster Regional Medical Center (Channel 1)
462.3000	Lancaster General Health (Services)
462.7750	Fire Repeater (Crossband for 33.56, 33.64, 33.68 and 33.72 MHz)
463.0000	Medical Channel 1
463.0250	Medical Channel 2
463.0500	Medical Channel 3
463.0750	Medical Channel 4
463.1000	Medical Channel 5
463.1250	Medical Channel 6
463.1500	Medical Channel 7
463.1750	Medical Channel 8
464.4250	Health Campus (Security)
464.7000	Lancaster General Health (Security)
464.7750	Lancaster Regional Medical Center (Channel 2)
464.8750	Heart of Lancaster Regional Medical Center (Channel 2)

That’s all for this month. Keep those questions, comments and reception reports coming to me at danveeneman@monitoringtimes.com and check my web site at www.signalharbor.com for more information related to scanners and radio technology. Have a safe and enjoyable Halloween and until next month, happy scanning!



Q. Years ago, when they started selling FM radios, we were told that part of FM's wonderful performance was that a station would "capture" your radio, and station drift would no longer be a problem. But, in the past year or two, I've been plagued by having nearby stations on the dial coming through just like AM stations step on one another, so that I'm hearing two programs at a time on my car and home radios. What gives? (Bob Compton, Breinigsville, PA)

A. I remember that era as well. I had a small, wood-encased Pilot tuner that had an RCA phono plug to connect to any audio input on a phono or console AM radio. That was the period that led to the 1950s hi-fi boom. In those days, FM stations were scarce and the likelihood of co-channel interference was minimal. Now, with the reduced popularity of AM, FM stations are increasing in number.

While co-channel AM signals do, indeed, blend into a cacophony of sound regardless of their relative signal strengths, FM signals exhibit the capture effect, whereby the stronger of the two dominates, effectively blocking the other. But what happens when two FM signals are of equal strength or, as is happening now, propagation shifts strengths back and forth? The garbling of both is heard.

Q. Will my Hughes satellite transmitter, emitting 1 watt on 2.6 GHz, affect reception on a Winradio G305e? I plan to get the downconverter to extend the G305e to 3.5 gigs. Its antenna will be 10-15 feet above and about 10 feet to the side of the satellite dish. (John Otey, email)

A. Certainly no damage will result and I really doubt you'll suffer any interference either with the original 1.8 GHz cutoff. But you may see some overload interference once you've installed the converter depending on how much side-lobe signal from that dish spills over to the G305e antenna. If you do, and it interferes with a needed part of your listening spectrum, you might try moving your receiving antenna more to the rear of the dish. If that isn't enough, you

may want to install a 2.6 GHz trap between your G305e and its coax line. Remove it when you need to listen near that frequency.

Q. I'm having intermittent problems picking up 700 MHz digital signals on my desktop scanner with a telescoping antenna. How can I improve the reception?

A. If reception is spotty, it could be your location, the distance to the 700 MHz antenna tower, or your antenna. Since you are using a desktop scanner, it's a safe bet that you are inside your home.

Worst case scenarios are in a low (near ground) position; behind metalized Mylar insulation in the walls; nestled in among higher structures; behind a mountain or hill; farther than 10 miles from the transmitters; using a poor antenna.

First, adjust the length of your antenna to about 4 inches since that would be the resonant length of a 700 MHz quarter-wavelength antenna. You can also try 12 inches (this 3/4 wavelength sometimes works better because it has more capture area). Tilt the antenna in different directions as well.

Also, try moving the scanner to a window facing the direction from which the signal is coming. Naturally, a high, outdoor antenna is always best. In some cases you can also use an attic crawl space.

Q. I lost the coupler unit for my H-800 active antenna. Can I substitute another power injector such as the WinRADIO WR-BT power injector or the WR-ACD-1800 Antenna Combiner? (John, K2AZ)

A. Any bias-T power inserter should work just fine just so long as it is designed for the same frequency range and delivers the correct voltage to the preamp on the H800.

Q. I used to be able to hear the wireless intercoms at drive-through restaurants with my scanner but no longer can find them at my Wendy's even using the Close Call™ search function.

Could they have gone digital? (Karen, email)

A. Yes. There is a trend upward in frequency (1.9 and 2.4 GHz bands) and using digital modulation. A company called Quail Digital specializes in such wireless headsets for the drive-through trade.

Q. What frequencies and modes do the Mars Rovers operate on? (Marv Gilliland, KC9RVL)

A. Curiosity transmits around 401 MHz to the transponder (MELACOM) on the Mars Reconnaissance Orbiter (MRO) which then talks back in the 437 MHz Amateur-Satellite Service band via two patch antennas. The MRO can talk with any of the Martian Rovers using CCSDS Proximity-1 protocol. A dish antenna transmits to Earth in the 7-8 GHz X-band.

Q. While driving through the suburbs, I see a lot of abandoned C-band satellite dish antennas, the old "big ugly dishes" ("BUDs"). Are there still services operating there?

A. There are very few analog C-band transponders still in use, so most old analog receivers won't work. Today, most C-band signals are digital transmissions and many of those are Free-to-Air (FTA), unencrypted, using MPEG2 or MPEG4 technology. You'll need a dish of 6 feet or bigger in diameter, an FTA receiver and a new C-band LNBF for successful viewing. The most up-to-date list of what's available is found at: <http://www.global-cm.net/mpeg2central.html>

Q. I occasionally will receive sub-channels on my digital TV with only the message, "Signal Cannot Be Decoded." Are these data channels? (Mario Filippi, N2HUN)

A. It simply means that the signal is too weak or too distorted from multipath to provide a reliable picture. In the old analog days, it would have been seen as a snowy or blurry picture.

Questions or tips sent to Ask Bob, c/o MT are printed in this column as space permits. Mail your questions along with a self-addressed stamped envelope in care of MT, or e-mail to bobgrove@monitoringtimes.com. (Please include your name and address.)



SDRs: Opening a Larger Window

SDR stands for Software Defined Radio. For utility listening purposes, this applies to radios where functions such as intermediate frequency (IF) filtering and signal demodulation are done by signal processing programs running on a computer or a dedicated digital device instead of the traditional hardware strip.

The military has been high on this concept for quite a while. For them, it offers an ability to more seamlessly change bands, nets, or modes by simple reconfiguration, rather than using a different radio that all participating units might not have.

More recently, SDRs have penetrated amateur radio and shortwave listening in a big way. They range from simple, very inexpensive, experimenter's boxes to highly sophisticated surveillance systems costing thousands of dollars.

For the past several months, this editor has been learning the ins and outs of SDR use in the pursuit of utility DX (distant or rarely heard stations). While there are definite tradeoffs, the SDR offers some new possibilities.

❖ SDR Types

Some SDRs are evolved from the latest, and still very viable, generation of stand-alone receivers using digital signal processing (DSP) in their IF. These contain the usual radio-frequency (RF) strips and mixer/oscillator down converters, plus some level of IF processing before the result is digitized and sent to the computer. The highly regarded WiNRADiO G313e is of this type.

A newer type of SDR digitizes the entire coverage band, down-converts it all with mathematical algorithms, and then uses the computer for everything else. The popular Perseus and the WiNRADiO Excalibur series are of this type. Much wider frequency bands can be received and processed this way, at the cost of a greatly increased demand on computer hardware.

As always in electronics, the choice here depends on application. The second kind is in use here, because the goal was to be able to find things faster on utility bands. While there are drawbacks, this hardware definitely makes it possible to open a larger window on the fast-changing world that is high-frequency (HF) communication.

❖ Wide-Spectrum Display

The first gosh-wow comes when the unit is started up for the first time, and a band which in some radios includes the entire HF spectrum appears on the screen. Broadcasts, with their

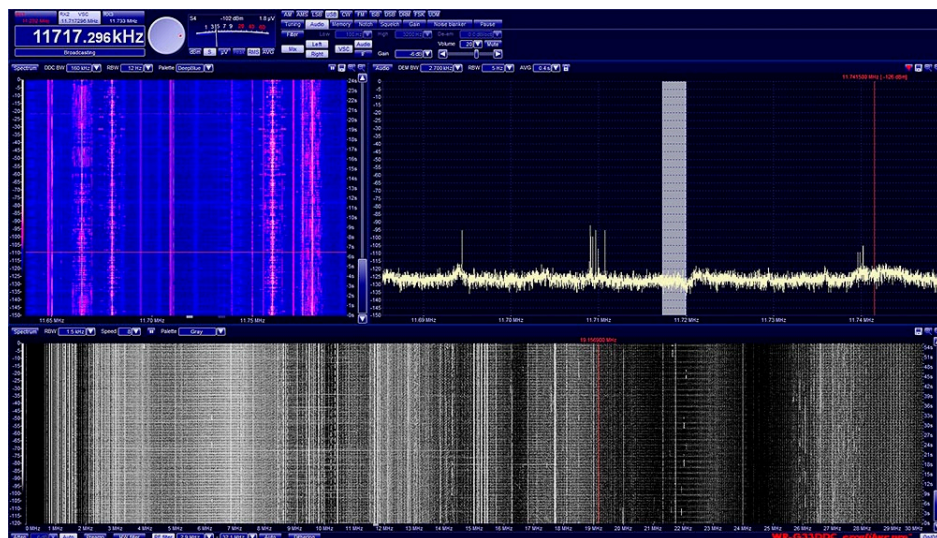

Excalibur SDR Screen Dump.

strong carriers, show up the best. The maritime bands look like collections of dotted lines, from intermittent Pactor and Sitor-A bursts. The time stations, which appear every five megahertz (MHz), immediately show propagation by their relative brightness.

After this, all the funny noises that have been previously regarded as nuisances become actually interesting. Right off, one can easily see what those pweeng, pweeng, pweeng sea surface radars are really doing, and how chaotic their bands around 4-5 MHz really have become.

Then there's the growing zoo of propagation sounders. It's really quite remarkable, with little squares (frequency-modulated swept-carrier bursts) jumping around the waterfall like fleas. The older "Chirpsounders," which just go dweep on a standard voice-band receiver, draw a diagonal line here. One starts using these as a very rough indicator of which frequencies have propagation.

It's also highly educational to compare the appearance of this display at the different times of day. Some people have even made time-lapsed videos of this, rather dramatically showing how signals, and even some of the noise, move up and down the band.

Finally, the waterfall has been known to light up rather dramatically over certain higher ranges of frequencies when these open up. It's much harder to miss those 15-minute openings above 26 MHz. This will come in quite handy this fall when propagation picks up.

❖ Recording

The real amazement starts, however, when the recording functions are used. A tried and true utility DX technique is to record audio of strange signals. Then it can be replayed, or sent to people with more knowledge, for analysis and hopefully identification.

With SDRs, though, it's usually possible to record large chunks of the IF bandwidth directly to disk. The Excalibur Pro can do 4 MHz, if the computer's up to it. One sits and watches their hard disk fill up. Usually, though, 500 kilohertz (kHz) is plenty.

Imagine waking up or coming home, and instead of having an audio recording of one frequency, being able to receive a whole band. It can be re-received with different filtering or whatever. Stations which transmitted at the same time can be heard the next time through. The rate at which one stumbles upon new frequencies can go up exponentially.

In addition, especially with Perseus users, there's now considerable swapping of SDR recordings. Also, quite a few remote outputs are available as real-time streams online. It's amazing, and a little dizzying, to be able to run someone else's RF as if it had come from your antenna.

❖ Digital Modes

One might ask what happens to traditional sound card decoding programs when there's no

sound card. This is a good question, and one without a definitive answer.

These programs can be used with add-on software such as Virtual Audio Cable (VAC) or WinRADiO's Virtual Sound Card. VAC has some setup, while VSC can be treated as another line input. When the program is set to select these or other such sources, it's as if analog audio was coming in the computer's line input.

There are catches, however. Some modes, such as RTTY (radio teletype) and HF DL (aircraft High-Frequency Data Link) work as if nothing had changed. Others, such as analog HF fax, can be tricky due to timing issues, buffering, or latency in processing. So far, fax here is unacceptably jumpy unless "Stereo Mix" is used instead of the virtual sources. This is fine, except that the only volume control is the computer's master, and fax gets positively earsplitting.

Users of Windows 7 should note that, even though it comes without Stereo Mix enabled, many sound drivers allow its re-activation by finding it under "disabled devices" and turning it back on. It worked here, though many other people haven't been so lucky.

❖ Conclusion

The SDR won't replace everything else in the typical utility DX arsenal any time soon. As with any technology, it has advantages and disadvantages. However, these radios can definitely help find weak utilities. The feeling that "HF is dead" quickly becomes one of "HF is alive, just a bit hidden." Have fun with this stuff.

❖ More Funny Noises

Lately, there's been a lot of interest in a noise that can be described most politely as resembling "breaking wind." This comes in bursts typically a second or two long, and about 8 kHz wide. As one can see clearly on an SDR, the actual waveform is continuous wave frequency modulation (CWFM). This is a slow form of FM in which a carrier is swept at a rate in the hertz or tens of hertz. It's what makes the "little squares" mentioned above.

Sometimes there are three beeps before or right after the burst. Other times, there are not. This is not always consistent, even in signals obviously from the same source.

There are two classes of devices using this waveform. These are propagation sounders and backscatter radar. The radar has been around the longest, but most of the blating noises being currently reported are probably high-powered sounders. The use of these has increased dramatically. Some are used along with the radar to find the best places to transmit. Others have the usual military and research applications.

A variation on this theme is a much rarer CWFM sweeper that is more like 30 kHz wide. Its source is something of a mystery. In the normal voice-bandwidth receiver, its longer cycle time of about four hertz makes it sound like a repeating movie space gun.

This signal has a very good chance of being the "phaser" sound reported on some pretty busy frequencies. People really took note when it appeared on 11175 kHz, a primary US Air Force Global channel. It's clear that some of these noises are better at picking empty spots than others.

ABBREVIATIONS USED IN THIS COLUMN

AFB.....	Air Force Base	M89.....	Chinese military CW coded/group call signs
AFRTS.....	American Forces Radio and Television Service	MARS.....	U.S. Military Auxiliary Radio System
ALE.....	Automatic Link Establishment	Meteo.....	Meteorological; weather office
AM.....	Amplitude Modulation	MRHS.....	Maritime Radio Historical Society
AWACS.....	Airborne Warning and Control System	MX.....	Generic for Russian single-letter beacons/markers
CAMSLANT.....	Communications Area Master Station, Atlantic	PACTOR.....	Packet Teleprinting Over Radio, modes I-IV
COTHEN.....	U.S. Customs Over-The-Horizon Enforcement Network	RTTY.....	Radio Teletype
CW.....	On-off keyed "Continuous Wave" Morse telegraphy	S28.....	Russian strategic "buzzer" and short voice messages
DHFCS.....	UK Defence High-Frequency Communications System	Selcal.....	Selective Calling
DSC.....	Digital Selective Calling	SIPRNET.....	Secret Internet Protocol Router Network
EAM.....	Emergency Action Message	SITOR.....	Simplex Telex Over Radio, modes A & B
FAX.....	Radiofacsimile	UK.....	United Kingdom
FEMA.....	U.S. Federal Emergency Management Agency	Unid.....	Unidentified
FSK.....	Frequency-Shift Keying	U.S.....	United States
HF DL.....	High-Frequency Data Link	USAF.....	U.S. Air Force
HFGCS.....	High-Frequency Global Communications System	USCG.....	U.S. Coast Guard
LDOC.....	Long-Distance Operational Control	V13.....	Taiwan "New Star," music and numbers in Chinese
LSB.....	Lower Sideband	VC01.....	Robotic "Voice Chip" Chinese numbers
M51.....	French military Morse code drill messages	Volmet.....	Scheduled, formatted, aviation weather broadcasts

All transmissions are USB (upper sideband) unless otherwise indicated. All frequencies are in kHz (kilohertz) and all times are UTC (Coordinated Universal Time). "Numbers" stations have their ENIGMA (European Numbers Information Gathering and Monitoring Association) designators in ().

509.1	WD2XSH/5 Station 5 in the American Radio Relay League 600-Meter Experimental Group, NH, CW beacon at 0306 (Mario Filippi-NJ).	5419.0	FAV22-French Morse code training (M51), Favières/ Vernon, CW drill messages in 5-letter groups; also on 6853, 6949, 7823, 7844, and 7966; at 1907 (MPJ-UK).
518.0	"N"-USCG Camslant Chesapeake (NMN), VA, Sitor-B Navtex with storm warning for MD, at 0200 (Filippi-NJ).	5446.5	AFN-American Forces Network, an AFRTS Interruptible Voice Channel, as rebroadcast from U.S. Navy, Saddlebunch Key, FL, talking about health care overseas, at 0347 (Filippi-NJ).
523.0	JJH-Non-directional aero beacon, Johnstown, NY, CW identifier at 0303 (Filippi-NJ).	5500.0	QV5B-M89, calling 7NPE in CW, at 1453. 3A7D-M89, calling DKG6 at 1455 (Boender-Hong Kong).
3246.0	Unid-Russian Air Defense, CW tracking strings of null data stamped with local time but fast; parallel 5221.5, 5752, and 9222; at 2053 (MPJ-UK).	5708.0	Armor-French Navy, Brest, working VN, at 0656 (Lacroix-France).
3797.0	DRV8-Chinese military coded CW callups (M89), marker calling H2FL, at 1502 (Ary Boender-Hong Kong remote).	5875.0	CHR-U.S. National Guard, calling JOCNCGSTA, presumably NC National Guard, ALE at 1903 (Jack Metcalfe-KY).
4212.0	XSQ-Guangzhou Radio, China, CW identifier in Sitor-A burst marker, also on 8435, at 2031 and 2045 (MPJ-UK).	6340.5	NMF-USCG, Boston, MA, FAX sea state analysis at 1801, and North American Ice Service map at 1816 (Filippi-NJ).
4215.0	XSG-Shanghai Radio, China, CW identifier in Sitor-A marker, also on 8425 and 12637.5, at 2043 (MPJ-UK).	6699.9	Veilleur-French Air Force, working Cyrano 201, probable E-3F AWACS #35-CA, at 1251 (Lacroix-France).
4343.0	Unid-Chinese Robot (VC01), fast robotic numbers in Chinese, LSB at 1029, 1218, and 1525 (Boender-Hong Kong).	6715.0	JGSPR-USAF SIPRNET, Diego Garcia, ALE sounding at 2000 (Lacroix-France).
4553.5	ZPRI-German Customs Boat Priwall (DLVI), calling ZLST, Customs Control Post, ALE at 2311 (MPJ-UK).	6733.0	ISAF 434FK-UK Royal Air Force, getting weather and soccer scores from Tascomm, UK Terrestrial Air/ Sea Communications, at 2320 (ALF-Germany).
4625.0	"The Buzzer"-Russian military, AM channel marker for UVB-76/ MDZhb (S28), at 1940 (Michel Lacroix-France).	6745.0	MOBE3F-French Air Force E-3F, probably Cyrano 201, ALE and voice with Avord, at 2113 (MPJ-UK).
4724.0	Andrews-USAF HFGCS, Andrews AFB, MD, 28-character EAM with prefix W5OKDN, at 0543 (Hugh Stegman-CA).	6858.0	Unid-Chinese Robot (VC01), LSB at 0806 and 1215 (Boender-Hong Kong).
4885.0	Unid-Mexican Navy, Spanish "Radiograma" dictation with Tadiran radio beep on key-up, also some Tadiran autocalls underneath, at 0320 (Stegman-CA).	6908.5	RRF-Possible U.S. Army, calling AASF2CMD (Army Aviation Support Facility 2), also on 7720, at 1506 (Metcalfe-KY).
5100.0	ALA-Unknown, short for "Alpha," ALE link checks with BRO, "Bravo," and JLUSNET, also on 7900, at 2232 (ALF-Germany).	6985.0	228SIG-U.S. National Guard 228th Theater Tactical Signal Brigade, SC, net with several other SC stations; also on 9295, 10703, and 10818, at 1600 (Metcalfe-KY).
5101.0	RFX41-Russian Navy vessel, working RCV, Black Sea Fleet headquarters, CW at 2319 (ALF-Germany).	7005.0	RGT77-Russian military, signing after a CW broadcast message in Cyrillic 5-letter groups, at 221 (MPJ-UK).
5195.0	DRA5-German amateur propagation beacon, Sheggerott, CW bulletin at 2006 (MPJ-UK).	7039.2	"L"-Russian military CW channel marker (MX), should be cluster beacon "E," Vladivostok, at 0731 (Boender-Netherlands).
5295.0	XSS-UK DHFCS control, Forest Moor, ALE sounding; also on 6251, 8107, 8980, and 9022; at 2208 (MPJ-UK).	7428.0	FR7FEM002-FEMA Region 7, KS, ALE sounding at 0230 (MDMonitor-MD).

7527.0 J01-USCG MH-60T Jayhawk #6001, ALE sounding on COTHEN, at 0151 (MDMonitor-MD).

7596.0 EK9-Greek military, usual ALE contact with GEF, at 2015 (MPJ-UK).

7598.0 "41"-Italian Carabinieri, working unknown station in LSB, at 0815 (Lacroix-France).

7606.0 GNXG-M89, calling WITN, also on 7607, CW at 1453 (Boender-Hong Kong).

7830.0 IN10-Algerian Military, ALE link check with T510, at 2000 (ALF-Germany).

8055.0 1001-Mauritanian Gendarmerie Nationale, calling 1004, also on 10033, ALE at 2340 (ALF-Germany).

8116.0 HQ5E-Russian Military tactical call, CW traffic for DULA, similar on 8138, at 2023 (MPJ-UK).

8132.0 BPLEZS-German Water Police, Cuxhaven, ALE and voice with BP22, Police Boat *Neustrelitz* (DBIF), at 1754 (MPJ-UK).

8190.0 SALONE-Italian Financial Police fast boat *Salone* (G-123), working PRATICA01, aviation center at Pratica di Mare, ALE at 1747 (MPJ-UK).

8345.0 RGZ58-Russian Navy vessel, CW chatter with unknown station, at 1925 (ALF-Germany).

8414.5 A8YW7-Liberian flag cargo vessel *DS Charme*, DSC with Odessa, at 2102. UGJP-Russian flag cargo vessel *Gelius 2*, DSC with Istanbul, Turkey, at 2110 (Lacroix-France).

8424.0 SVO-Olympia Radio, Greece, CW marker at 0146 (Filippi-NJ).

8446.5 HEB-Global Link/ Berne Radio, CW identifier in Pactor marker, at 0736 (Lacroix-France).

8462.0 9MR-Malaysian Navy, Johore Bahru, RTTY marker at 1847 (MPJ-UK).

8484.0 HLG-Seoul Radio, Korea, CW marker at 1839 (MPJ-UK).

8494.7 "D"-MX cluster, Odessa, also on 13527.7 and 16331.7, CW at 1947 (MPJ-UK).

8494.8 "S"-MX cluster, Severomorsk, CW at 1948 (MPJ-UK).

8495.0 "C"-MX cluster, Moscow, also on 13528 and 16332, CW at 1949 (MPJ-UK).

8497.8 "L"-MX, St. Petersburg, should be "F," Vladivostok, CW at 1934 (MPJ-UK).

8503.9 NMG-USCG, New Orleans, FAX schedule list at 0234 (Filippi-NJ).

8582.5 KLB-ShipCom, WA, special CW marker for thirteenth "Night of Nights" commemorating maritime Morse telegraphy, at 0156 (Stegman-CA).

8638.5 DAO38-Global Link/ Kielradio, CW identifier in Pactor marker, at 1953 (MPJ-UK).

8658.0 WLO-ShipCom/ Mobile Radio, AL, special Night of Nights CW marker at 0118 (ALF-Germany).

8886.0 VQ-BFW-Ural Airlines A320, flight U60265, HFDL log-on with Krasnoyarsk, Russia, at 1953 (MPJ-UK).

8888.0 Sytkyvkar-Russian Volmet, male voice in Russian with aviation weather, also on 11318, at 1932 (MPJ-UK).

8903.0 Kinshasa-Africa/ Indian Ocean air route control, Congo, working unknown aircraft (?) 383GDH, at 1939 (PPA-Netherlands).

8906.0 EC-KQC-Garuda Indonesia B747, flight 4103, answering selcal CP-GH and passing position to New York, at 0337 (PPA-Netherlands).

8912.0 F35-USCG HU-25C Falcon Jet # 2135, ALE sounding on COTHEN, at 1300 (MDMonitor-MD).

8912.0 UAL004-United Airlines B777, HFDL position for Riverhead, at 0714 (Lacroix-France). F35-USCG HU-25C Falcon Jet # 2135, ALE sounding on COTHEN, at 1300 (MDMonitor-MD). [Yes, 8912 is both COTHEN and HFDL. -Hugh]

8918.0 New York-North Atlantic air control, working United Airlines B757 reg N563UA, at 0223 (PPA-Netherlands).

8927.0 PK-GMD-Garuda Indonesia B737 flight GIA876, HFDL position for Guam, at 1926 (PPA-Netherlands).

8930.0 Stockholm-Stockholm LDOC, Sweden, making selcal checks at 0500 (Tony Agnelli-FL). N219CY-ABX Air B767 freighter, flight 978, selcal check JQ-MP on the ground at Charles de Gaulle (CDG), France, at 1930 (PPA-Netherlands).

8933.0 New York LDOC-Aeronautical Radio, Inc., patch for unknown aircraft, at 0246 (PPA-Netherlands).

8939.0 St. Petersburg Volmet, Russia, aviation weather in Russian, at 1838. Rostov-na-Donu Volmet, Russia, aviation weather in Russian, at 1856 (PPA-Netherlands).

8942.0 GAF0879-German Air Force A319 #15-0, HFDL position for Shannon, at 1728. 9V-JSA-Jetstar Asia Airways A320, flight 842, selcal check and position with Singapore, at 2042 (PPA-Netherlands).

8948.0 "17"-HFDL Canarias ground station, Grand Canary Island, uplink to ZS-SNI, a South African Airways A340, at 2024 (PPA-Netherlands).

8957.0 Shannon Volmet, Ireland, aviation weather for European airports, at 1902 (PPA-Netherlands).

8965.0 DHM 91-German Air Force, Munster, selcal and voice calls to unknown aircraft, no joy at 0758 (Lacroix-France).

8968.0 PLASPR-USAF SIPRNET node, Lajes Field, Azores, ALE sounding at 1952 (PPA-Netherlands).

8971.0 Wafer 711-U.S. Navy P-3C, calling Fiddle (U.S. Navy Technical Service Center, FL), no joy at 1223 (MDMonitor-MD).

8977.0 N744CK-Kalitta Air B747 freighter, flight K4247A, HFDL update to Reykjavik, at 1758 (PPA-Netherlands).

8992.0 Andrews-USAF HFGCS, 22-character EAM, prefix W52OYM, at 1803 (PPA-Netherlands).

9025.0 170045-USAF C-5B #87-0045, ALE sounding at 0543 (MDMonitor-MD). PLA-USAF, Lajes Field, Azores, ALE sounding at 0902 (Lacroix-France).

9140.0 ZLTU-Commonwealth of Independent States military, CW Cyrillic message in 27 5-letter groups, at 1410 (MPJ-UK).

9248.0 RGZ59-Russian Navy warship, working RCV, Sevastopol, CW at 2010 (MPJ-UK).

9276.0 New Star Radio Station-Program #3 (V13), Chinese music and live female with coded messages, at 0800 (Boender-Hong Kong).

9996.0 RWM-Russian standard time and frequency station, Moscow, CW identifier and clock pips, at 1709 (MPJ-UK).

10000.0 "Friends of Italcable"-Italian quasi-amateur "time station," Viareggio, with music, data bursts, and voice time announcements, at 1925 (ALF-Germany).

10024.0 Cenamer-South American air route control, Honduras, selcal check HQ-RS with American flight 997, a B767 reg N378AN, at 0441 (PPA-Netherlands).

10051.0 Gander Volmet, Canada, aviation weather at 0421 (PPA-Netherlands).

10063.0 HC-CJV-AeroGAL flight 2K0607, HFDL position for Albrook, Panama, at 0441 (PPA-Netherlands).

10066.0 MJN530-Royal Air Force of Oman flight, HFDL position for Hat Yai, Thailand, at 1744 (PPA-Netherlands). 4K-AZ81-Azerbaijan Airlines B767, flight J20078, HFDL position for Hat Yai, at 1949 (MPJ-UK).

10075.0 P4MES-Roman Abramovich private B767, flight UVP4ME, HFDL position for Al-Muharrag, at 1755 (PPA-Netherlands).

10081.0 N452UP-United Parcel Service, flight UPS369, HFDL position for San Francisco, at 0436 (PPA-Netherlands).

10087.0 MM-62227-Indian Air Force KC-767A tanker, flight IT0000, HFDL position for Krasnoyarsk, at 1922 (MPJ-UK).

10090.0 Tashkent Volmet, Uzbekistan, aviation weather at 1813 (PPA-Netherlands).

10588.0 FC1FEM FEMA Region 1 communications, MA, calling FCSFEM, Mt. Weather Emergency Assistance Center, VA, at 1532 (MDMonitor-MD).

11030.0 VMC-Charleville Meteo, Australia, noisy FAX wind analysis chart at 1803 (PPA-Netherlands).

11039.0 DDH9-Hamburg/ Pinneberg Meteo, Germany, RTTY identifier at 1916 (PPA-Netherlands).

11056.7 Unid-Egyptian MFA, Cairo, selcal TVVX to Algiers embassy, then Sitor-A traffic in Arabic alphabet, at 1926 (PPA-Netherlands).

11086.5 GYA-UK Royal Navy, Northwood, FAX surface chart at 1820 (PPA-Netherlands).

11111.0 STAT21-Tunisia National Guard, calling TUD in ALE, at 0817 (Lacroix-France).

11175.0 Reach 3265-USAF Air Mobility Command, patch via Sigonella HFGCS, Italy, to Dover AFB (DE) base ops, went to 4724, then back on triple-1 declaring inflight emergency for fire indication only, returning to base, at 0151 (Allan Stern-FL). Lifter Key One-Probable USAF C-17A LIFTR aircraft, radio check with Offutt HFGCS, at 1530 (Dean-CA).

11181.0 MCCSPR-USAF SIPRNET node, McClellan AFB, CA, ALE sounding at 1540 (MDMonitor-MD).

11220.0 Andrews-USAF HFGCS, MD, secure comm check with Fuzzy 99, U.S. Air National Guard tanker, at 1413 (Stern-FL).

11226.0 170034-USAF C-5B #87-0034. ALE sounding at 0041 (MDMonitor-MD).

11232.0 Trenton Military-Canadian Forces, ONT, patching U.S. Navy P-3C Wafer 712 for ops-normal report, at 1907 (MDMonitor-MD).

11300.0 Tripoli-Africa/ Indian Ocean air route control, radio check with Cairo, Egypt, at 1958 (PPA-Netherlands). [Back on after war. -Hugh]

11309.0 N772LA-LAN Cargo B777 freighter, calling Santa Maria, at 2038 (PPA-Netherlands).

11312.0 A6-EDE-Emirates Airlines A380, flight UAE202, HFDL position for Molokai, Hawaii, at 0551 (PPA-Netherlands).

11318.0 LV-CKU-LAN Argentina (ex-Dominicana) B767, flight 4M4520, HFDL position for Santa Cruz, Bolivia, at 0457 (PPA-Netherlands).

11330.0 New York-Caribbean air control, working United 1414, at 1955 (PPA-Netherlands).

11345.0 SDJ-Stockholm LDOC, selcal check LS-HJ with PH-HZB, Transavia flight 6118, at 2011 (PPA-Netherlands).

11348.0 F-HJPC-Air France A380 flight AFR995, HFDL position for Canarias, at 2039 (PPA-Netherlands).

11354.0 Priboj-Russian Navy air transport, Moscow, working unheard aircraft at 1845 (PPA-Netherlands).

11384.0 "07"-HFDL ground station, Shannon, Ireland, uplink to N577FE, a FedEx MD-11 freighter, at 1725 (PPA-Netherlands).

11390.0 Murmansk-Russian air control, working Emirates flight UAE217, at 0549 (PPA-Netherlands).

11396.0 New York-Caribbean air control, working Air Canada 961, an A319 reg C-FYJP, at 2039 (PPA-Netherlands).

11430.0 New Star Radio Station-Program #4 (V13), music and messages at 0500 and 1210 (Boender-Hong Kong).

12222.0 716-USCG HC-130H #1716, raised LNT, Camslant, ALE on COTHEN, then gave a voice ops-normal report at 0030. LNT, ALE with 003, USCG HC-130J #2003, who secured radio guard in voice, at 2305 (MDMonitor-MD).

12577.0 C6FN7-Bahamas flag cruise ship *Silver Whisper*, DSC request to sister ship *Silver Cloud* (C6MQS) for a voice contact, at 1157 (MPJ-UK).

12695.5 KFS-MRHS, CA, special CW Night of Nights broadcasts at 0452 (Eddy Waters-Australia). [KPH and KFS calls belong to *Globe Wireless* rest of year. -Hugh]

12993.0 KSM-MRHS commercial coastal traffic station, CA, CW for Night of Nights, at 0452 (Waters-Australia).

13118.0 ABA-Maltese Maritime Squadron Headquarters, Floriana, ALE text message for AB2, Patrol Boat P-22, also on 16402, at 1143 (MPJ-UK).

13215.0 MCC-USAF, McClellan AFB, CA, ALE sounding at 0638 (Lacroix-France).

13244.1 Pipeline-U.S. military, probably Hawaii, working units in the field at 0645 (Waters-Australia).

13312.0 K06-USCG MH-65C Dolphin #6506, ALE sounding on COTHEN, at 1611 (MDMonitor-MD).

13528.1 "A"-MX, Astrakhan, CW at 1634 (MPJ-UK).

13907.0 D23-U.S. Customs P-3B "Slick," reg N423SK, ALE sounding on COTHEN, at 2251 (MDMonitor-MD).

13927.0 Dawg 03-U.S. Air National Guard C-130H, patches to maintenance and ops via AFA5RS (USAF MARS, IN), shutting down #2 engine for no oil and returning, at 1725 (Stern-FL).

13945.0 TU2-Tunisian Military/ Ministry of Information, working STA and WU2, ALE at 1229 (MPJ-UK).

14484.0 Desert Eagle-U.S. Army MARS control station, possibly AZ, radio check with a weak Army Mars station not using the "Showdown" call, at 1923 (MDMonitor-MD).

14582.0 LNT-Camslant, ALE with N13, USCG HC-144A Sea Sentry #2313, who then gave position in voice, at 1737 (MDMonitor-MD).

15091.0 ADWSPR-USAF SIPRNET node, Andrews AFB, MD, with an ALE sounding; followed by OFFSPR, Offutt AFB, NE, with same; at 2145 (MDMonitor-MD).

15867.0 TSC-U.S. Customs and Border Protection Technical Services Center, FL, calling K91, USCG MH-65D Dolphin, ALE at 1945 (MDMonitor-MD).

16331.0 "C"-Russian Navy CW cluster beacon (MX), Moscow, at 1832 (Filippi-NJ).

16804.5 5BVA2-Cyprus flag freighter *Berlioz*, DSC safety message with Joint Rescue Coordination Center, Piraeus, Greece, at 1304 (MPJ-UK).

16806.5 NMF-USCG, Boston, MA, Sitor-B weather at 1632 (Lacroix-France).

17016.8 KPH-MRHS, special event call for Night of Nights, CW at 0338 (Waters-Australia).

17976.0 ADWSPR-USAF SIPRNET node, Andrews AFB, ALE sounding at 1843 (MDMonitor-MD).

18003.0 CRO-USAF HFGCS, Croughton, UK, calling an unknown aircraft in ALE, at 2200 (MDMonitor-MD).

21982.0 7T-VJX-Air Algérie A330, flight AH1005, HFDL log-on with Al-Muharrag, Bahrain, at 1632. UK-32016-Uzbekistan Airways A320, flight XX0687, HFDL log-on at 1725 (MPJ-UK).

22477.5 KPH-MRHS, CA, special Night of Nights CW marker, at 0150 (Stegman-CA).

25625.0 Unid-Spanish AM "freeband" skip, many strange electronic noises and echo boxes, similar chatter on 53 other frequencies all the way to 28055, all at 0101 (Stegman-CA).

27870.0 OFFSPR-USAF SIPRNET node, ALE sounding at 1934 (MDMonitor-MD).



Fall Digital Smorgasbord

This month, we take a look at a number of digital ALE (Automatic Link Establishment) networks on HF that still need deeper monitoring and investigation to pinpoint their origin. Armed with the right decoding software, why not join in and see if you can help crack them? Free software is available from a number of sources (see Resources).

❖ The 3 Letter Net

Covered in detail in the December 2010 and updated in the October 2011 issue of this column, this U.S.-based network still defies 100% identification, although recent monitoring suggests that this could be a high-level FEMA operation.

Active during every third week of the month, these stations keep office hours and are busy with MIL-188-141A ALE link quality checks and occasional STANAG4197 (aka ANDVT or Advanced Narrowband Digital Voice Terminal) traffic. Encrypted text messages via ALE's DBM (Data Block Message) protocol also continue to be observed, like this one from station "RRL":

```
[THIS WAS] RRL [DBM]
cAcLmzjq~jTEDg3IX?OqBvgaK4JQV:CbU6EdJE%
GuT|:Oz#zJC:bf4;fob?Pu{TL{*|CRp,|,lr6l7L
=qr`Qw}?z~JJ"jR@]rjV$[_~t6l
etc, etc
```

Here are the station identifiers used by this network:

- ALN, AMK
- BFG, BGD, BLL, BRX, BVO
- CNU, CTB
- EDK
- FNF, FPR, FSM
- GCL, GHM, GWO
- HQ1, HPT, HYR
- IRK
- JES
- KNY
- LPP, LXV
- MBY, MCK, MHE
- RHV, RRL
- TDD, TTD
- VSF
- ZFA

And, here's where you can hear these stations:

4444.6, 4934.1, 5690, 7325, 7835, 8045.6, 9019, 10150, 11238, 12103, 13438.6, 15037, 16090, 18021, 23265, 25441.6 kHz USB

❖ A New Pacific Network?

This network was found in late July, initially on 10995 kHz USB, but was later found on a number of other channels. Here in Maine, stations using the 10 MHz channels fade in around 2300UTC and fade out at around 0800UTC which suggests a Pacific Rim or Eastern Australian location. The clustered channel groupings are suggestive of an NVIS (Near-Vertical Incidence Skywave) network

designed for coverage over a relatively small area often with mobile stations.

The identifiers in use are CA5UG (probably the NCS - Network Control Station), HJ6BG, INTI, JL6LS and OT8WQ.

The channels heard so far include: 6465, 6495, 6510, 10930 and 10995 kHz USB. Stations send frequent data traffic using the MIL-188-110A 39 tone modem though, at this location, the signals are too weak for a reliable decode. Unfortunately, I'm unaware of any free software that supports this mode.

If you are located in the West Coast of the U.S., you will probably receive better signals from this network, so please send me details of any ALE traffic such as text messages that might help unlock the origin.

❖ Lone Wolves

There are a number of stations that appear to be the sole users of their channels and perform nothing other than a regular ALE sounding. There's no linking with other stations, no data and no voice; encrypted or otherwise. Again, more monitoring and propagation analysis via fade-in and fade-out times can help identify the location of these stations. Here are a few:

```
PRI: 10154.5 kHz USB
HIJ: 7870, 11448 and 16011 kHz USB
K1QSAC, K4FSAC, Z6HSAC: 6985, 8139,
10819.5, 12076, 14523 and 16117.5
kHz USB
```

Once again, reception reports from your location would be greatly appreciated.

❖ The x0x/x1x Network

This network was found around about the same time as the suspected Pacific Rim system (see above). What is distinctive in this case is that the three digit ALE identifiers all contain either a zero or a one as the middle digit. Whereas some of our other mystery networks trigger voice activity, send text messages or modem activity, this network seems to do little other than sound or perform link quality assessments with other stations.

The identifiers heard so far are: 101, 102, 104, 106, 107, 201, 202, 203, 204, 205, 206, 207, 208, 209, 210, 211, 303, 304, 305, 308, 401, 403, 404, 406, 407, 408, 411, 413, 414, 416, 501, 502, 504, 604, 605, 701, 702, 703, 704 and 705. Frequencies used by this network include 14698 kHz USB.

❖ US MARS Transitions to High Speed HF Modem Standards

The U.S. Military Affiliate Radio Service (MARS) has been a long-time inhabitant of HF radio, still using SSB voice to coordinate

most of its activities. Like many HF users, over the past years, a number of stations in the Navy, Army and Air Force branches of the service have moved their data transmission from RTTY and SITOR to Packet Radio and onto GTOR and PacTOR. While MIL-188-141A ALE signals have been used for some time, lately, several stations have been copied using the MIL-188-110A 2400bd high speed HF modem, PacTOR-III in addition to some unidentified OFDM (Orthogonal Frequency Domain Modulation) modem.

Channels recently active with high speed modem activity include 17443 kHz USB where there is daily activity from Fort Huachuca in Arizona. Call-ups are completed with standard 75bd/850 RTTY followed by MIL-188-110A modem traffic. Here is a typical message using the high speed modem:

RYYRYRYRYRYRYRYRY

```
VZCZCWAP008 UU
RR UHEAA UHEAB UHEAC UHEAD UHEAE UH-
CAA UHCAB UHWAA UHWAB UHWAC
DE UHWAP
ZNR UUUUU
R 152015Z DEC 2011
FM CHIEF ARMY MARS FT HUACHUCA AZ
TO ALL ARMY MARS
BT
UNCLAS
MSGID/GENADMIN,USMTF,2007/ARMY
MARS HQ//
SUBJ/CAM 15-2011
```

Note the use of NATO ACP format messaging and routing indicators; "UHWAP" being Huachuca which corresponds to the regular call sign "AAZ". Traffic using the classic 75bd/850 Hz RTTY modem is the same.

Recently, Navy MARS units have also been copied using the 110A high speed modem in addition to PacTOR-III. NN-N0AAG was heard sending a test message to NNN0ALL (likely a collective call sign) on 14383 kHz USB.

❖ Epilog

Over a decade or so of this column's existence, I've received many emails and letters from readers with all kinds of questions about HF digital utilities, software and how to get going with the kinds of signals I cover here. So, please keep the correspondence coming. It's always appreciated. Until next month.

RESOURCES

MARS ALE: http://www.n2ckh.com/MARS_ALE_FORUM/sele200.html
PC ALE: <http://hfink.com/pcale/>



Linear Amplifiers: Myth vs. Reality

Although many of you know me as a crusader for QRP and stealthy operation, I will confess to having used high-power linear amplifiers. In my ARRL HQ days I bought (via an employee auction) a 3CX800A7 HF amplifier that was featured as a construction article in an edition of *The ARRL Handbook*. The amplifier sat on my operating desk for several years, looking good but almost completely unused, because I lived on the third floor of a three-story walk-up in a tightly packed residential area and used attic-mounted antennas. A kilowatt of RF under those situations just didn't seem neighborly! I acquired the amplifier so I could use it when I bought a house, but that turned out to be impossible in Connecticut in the early '90s (on a single income with no winning lottery tickets).

In college, before heading East, I desperately wanted more power on 80 and 40 meters, so I scrounged parts and "got creative" when I built an amplifier that used a 4-400A tube that was a "broadcast pull," meaning that it was retired

on schedule, not because it had failed. Building that 125-pound monster was enlightening, exciting and scary as hell, especially when testing the 2500-V dc supply under full load, which involved a Corningware(R) glass bread pan filled with salt water – a handy 2-kW resistor (until the water boils). Don't try this at home!

The amplifier worked just fine, and the first winter night I used it I worked UA9KV in Asiatic Russia on 80 CW for a new one. Yay! The next night I worked three more Asiatic Russian stations with my 100-W rig running barefoot, which was a good thing because the massive amplifier was crushing my operating desk, which was in danger of failing! I took the chunky unit out of service with the intent of splitting the RF deck from the power supply, but the amplifier "went missing," and after I returned from Connecticut it was nowhere to be found.

Before that, I built an amplifier that was actually used on a regular basis. Straight out of an older *ARRL Handbook*, it featured a single 6146B pentode that boosted the 5 W signal from my Ten-Tec Argonaut to about 75 W. Because it used a tuned input filter it was initially tricky to set up, but very forgiving in day-to-day operation. I can't remember exactly when and why I cannibalized that little amplifier...but I did.

It's easy to become misty-eyed and even a bit mesmerized when thinking about big, beautiful amplifiers, especially if you look under the hood. Compared to today's diminutive solid-state mini-transceivers, those massive coils, tubes and variable capacitors look positively exotic and exude an aura of serious RF power. Heck, a typical amplifier probably weighs more than all of the rest of your station gear combined!

Just imagine what you could do with all of the RF power! (Go ahead, we've all done it.) Oh, the stations you could work and the pileups you could breeze through, etc! Why, if I had a big linear amplifier I could...For most hams, that's when the fantasy meets reality.

There are several reasons why most HF transceivers put out about 100 W (and not 500 or 1000), some are practical and some are economical. A few high-end models put out 200 or even 400 W, but that's mostly so contesters and DXers who have already optimized their antenna systems can drive large, inefficient amplifiers with plenty of headroom left over.

For typical hams, station amplifiers aren't useful and are more trouble than they're worth!

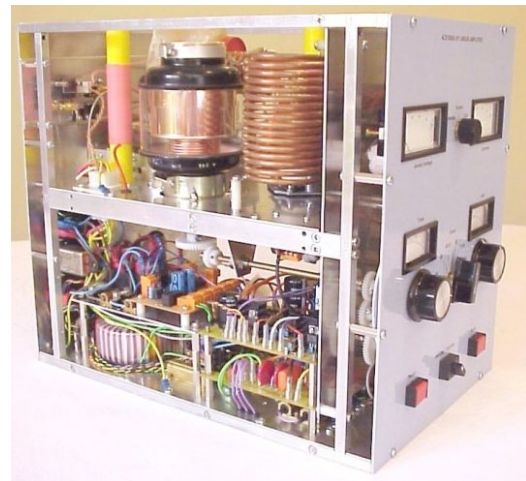

RF power amplifiers can be a "rite of passage" for advanced home-brewers, and some, like this 160-10M "desktop kilowatt," designed, built and tested by Mark Marsden, G4AXX, over a four-year period, are real works of art. Built around an Eimac 4CX1000A triode, the amp runs on 230 VAC and puts out 1400 W PEP from 25 or 100 W of drive (selectable). See more at www.granta.g4axx.com/linear.php3. (Courtesy: Mark Marsden G4AXX.)

So, if you think you need a linear amplifier to reach Radio Nirvana, think again. Your 100-W signal almost certainly provides more than enough power, and if you find yourself in need of a bigger signal, what you really need is a better antenna (and feed line) or improved operating skills. Until you've optimized those factors an amplifier is an expensive paperweight. I'll show you why.

First, Some Rules!

The Amateur Radio Service has plenty of rules, regulations and goals that transcend hobby operation. One of the most important compels us to minimize our RF output power as necessary. Specifically, Section 97.313(a) of the FCC Rules states: "At all times, an amateur station must use the minimum transmitter power necessary to carry out the desired communications."

Isn't that interesting? Section 97.313 doesn't rule out the use of amplifiers, of course, but if adhered to, seems to limit their automatic use. The "minimum necessary power" rule, which is broken thousands of times each day, protects hams and non-hams alike and promotes responsible, considerate operation.

In case you didn't notice, the FCC doesn't

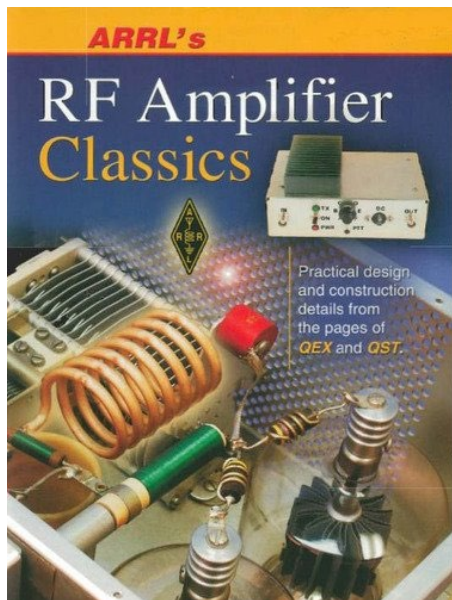

ARRL's RF Amplifier Classics contains 24 projects and articles from the pages of QST and QEX, published between 1980 and 2003 and covers amps for HF and VHF, from 5 W to 1.5 kW. Completing these amplifiers typically requires help from experienced builders, but beginners can learn a lot about how amplifiers are designed and built by studying these projects. ARRL's RF Amplifier Classics, \$19.95, is available from your favorite amateur radio bookseller or from www.arrl.org.

suspend the rule during contests, for DXers working rare stations or for those who happen to have amplifiers on hand. This rule is suspended, however, during communication emergencies. When lives are at stake, even the FCC green lights the use of any and all RF power.

Like many government rules, 97.313 suffers from a lack of precise definition. Practically, we know that “the minimum transmitter power necessary to carry out the desired communication” means that if 100 W produces a solid QSO, a kilowatt is “too much,” and violates of the spirit of the rule. For the lawyers in the room, though, the “desired communication” may be 40 dB more than what’s actually necessary.

“Your honor,” says the smarty-pants op with an amplifier hard-wired to the light switch in his shack, “that’s the communication I desired!” Don’t be a smarty-pants. Even if the rule is poorly articulated, we know what it’s supposed to mean.

By the way, the sections that immediately follow 97.313 are a confusing labyrinth of rules and regs pertaining to amplifier design standards and FCC type acceptance. After reading them I’m amazed that we have any commercial amplifiers at all!

Too Much for Too Little

As a typical ham who uses a 100-W rig that feeds a coax-fed dipole through an antenna tuner on several HF bands (I’m being purposefully presumptive here), you’re in a *poor position* to successfully deploy a linear amplifier. Yep! Your setup works pretty well and is used by thousands upon thousands of hams, but if you want better performance and stronger signals you won’t have much luck by simply inserting an amplifier into the mix. The fantasy of boosting your TX power certainly sells amplifiers, but you will get a lot more signal for a lot less money if you upgrade your antenna system before (or instead of) buying an amplifier.

Let’s amplify our signal to see just how bad the return on investment really is. A “small” solid-state or single-tube amplifier will boost your 100-W signal to about 500 W, which is barely enough to be noticeable. You’d think the difference would be much greater, but the math just doesn’t work out. Every time you double your power output, stations that are receiving your signal hear a 3-dB increase in strength. That’s less than half an S-unit! To nudge the needle a full S-unit you need to quadruple your power output (a 6-dB increase)!

The power output progression looks like this: 100 W doubled to 200 W equals a 3-dB increase. Next, 200 W doubled to 400 W equals a 6-dB increase. Then, 400 W doubled to 800 W equals a 9-dB increase (already more than the output power of an inexpensive amplifier). Finally, 100 W times 10 equals 1000 W, a 10-dB increase in power output.

A 500-W amplifier provides only a bit more than a 1 S-unit boost on the other end. Is a single S-unit worth \$600 to \$2000 (the cost of the amplifier)?

If you want more power the math gets even worse. As we learned, boosting your signal to a kilowatt provides a 10-dB shot in the arm, which is still less than 2 S-units on the other end, so if your 100-W signal was S5, it’s now a “whop-

ping “S7. That’s starting to be noticeable, but it’s hardly enough to make much of a difference when using your existing, non-optimized antenna system. And by the way, that meager increase in signal strength cost you \$1,500 to \$5,000 (and perhaps a trip to the chiropractor after you’ve carried the thing into the house)!

If you shell out for a legal-limit amplifier, your 1,500-W signal will be about 12 dB stronger than your barefoot transceiver. Because of the “price of power,” 1500 W is still only a teeny bit more than two S-units stronger! With price tags in the thousands, legal-limit amplifiers are hardly casual purchases.

In addition to the purchase price, amplifiers have other, sometimes hidden, costs. Without even considering long-term electricity costs, amplifiers are often bulky, heavy and many require 240-V ac service, which can add considerable additional expense if your shack isn’t outfitted properly. Some lower-power amps can run ok on 120 V, but potential problems abound. Any amp that puts out more than about 600 W needs 240-V service (and any amplifier that doesn’t put out more than 600 W isn’t much of an amplifier, a real Catch 22!).

Your feed lines, antenna tuners and antenna switches may also need to be beefed up to handle the additional power, and these high-power devices aren’t exactly inexpensive. And, don’t forget about actually interfacing your radio and your amplifier. It’s not as straightforward as it was back in the day; you may have to shell out extra bucks for hardware to preserve functionality such as full break-in. There can be lots of extra costs in addition to the amplifier itself!

Do These First

To save money and to keep your family, friends and neighbors from putting a pin through your coax, improve your antenna system (feed lines, too) before buying an amplifier. This is a *much better* idea! And remember: antenna and feed line improvements boost transmit and receive signals, whereas amplifiers only boost the former. Antenna system improvements provide twice the boost at a fraction of the cost.

As detailed in several antenna-improvement columns over the past year, one almost universal way to get more signal out is to get your antenna(s) farther up in the air (your present antenna or a new one). Build taller masts or towers or find taller trees. Higher is better!

Put up a better antenna. If, for example, your trusty dipole just isn’t cutting it, put up the budget DXer’s secret weapon, a full-wave horizontal loop for 40 or 80 meters (up as high as possible, of course!). Feed it with coax and use a tuner on bands *above* the fundamental frequency. That’s an inexpensive way to add an extra 2 to 10 dB to your communication budget, depending on frequency. See the April and May 2011 columns for details.

Use 450-ohm ladder line or 600-ohm open-wire feed line to replace your 50-ohm coax, which can be costing you 6 to 20 dB in precious signal strength depending on frequency and the physical size of your dipole. That’s a huge boost for only a few bucks! See the October 2011 column for more details.

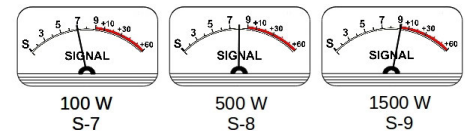

S-meters showing how power at 100, 500 and 1,500 watts is heard. When measured on the other op’s S-meter, the rather minimal signal boost provided by RF power amplifiers is starkly apparent. (Courtesy: Author)

Move your antenna tuner from your shack to the feed point of your antenna. Shack-mounted antenna tuners feeding multiband wire antennas with 50-ohm coax are often nothing more than fancy dummy loads! By placing an autotuner at your antenna feed point, all is forgiven. See the February 2011 column for details.

For about the price of an entry-level amplifier you can build a multiband beam antenna and buy a decent rotator. My favorite, considering cost vs. performance, is a home-brew hex beam. See W1GQL’s informative site at <http://midcoast.com/~w1gql/hex/hexbeam.htm> to get started. Mounted at least 40 feet above the ground, a hex beam provides a 5- to 7-dB directional improvement to your signal – times two! Amplifiers only boost your transmitted signal and do *nothing* to improve reception.

Directional antennas can boost desired signals while attenuating unwanted signals. For example, stations off the side of a beam antenna may be attenuated 25 dB or more! The difference, desired signals boosted 5 dB and undesired signals attenuated 25 dB, is more than 30 dB of signal enhancement, which could never be achieved by a legal amateur radio amplifier alone (unless you’re baseline is a 1-W QRP rig, which would output a kilowatt if its signal was boosted by 30 dB).

A properly adjusted speech processor (SSB only) can add 3-6 dB of TX signal boost for little or nothing. Learn to use the one that’s probably built into your rig or consider Ten-Tec’s Model 715 external RF speech processor (which has unfortunately gone up in price).

Morse code or digital modes such as PSK31 have a *lot more punch* than SSB. They offer vastly better signal-to-noise performance and open up new avenues of exploration. Heck, with PSK31 and similar modes such as Olivia, you barely need an antenna!

Buy an Amplifier If...

...You’ve carefully tweaked your antenna system. As detailed, amplifiers are really only useful after you’ve maxed out your antennas and feed lines. Add a 13-dB-gain amplifier to a 7-dB-gain beam antenna and you’ve got a whopping 20-dB signal strength improvement (not even counting the 7 dB received signal boost). That will put you on the map when conditions require maximum power to make a QSO possible (remembering your oath to the FCC to use your amplifier only when necessary).

MT’s 2012 Buyer’s Guide, part of the November 2011 issue, rates a bunch of HF amplifiers, tube and solid-state, fixed and mobile. Check it out if you’ve already tweaked your antenna system and are ready to take that final step.



GETTING STARTED

THE BEGINNER'S CORNER

Ken Reitz, KS4ZR

kenreitz@monitoringtimes.com

The More Things Change, the Better They Get...Mostly

It seems that every time we get comfortable with a new technology something “better” comes along to sweep it aside. Most of the time better really is better. For instance, who would trade music recorded on a compact disc for a stack of 78 RPM records? And, sometimes, better isn’t altogether better. For instance, everyone knew that cassette tapes with their ultra-narrow gauge tape moving at a very slow speed couldn’t measure up to the audio fidelity of one-quarter inch, high-speed, open reel tape. But, we were willing to sacrifice the fidelity for portability. No one was going to go jogging with a reel-to-reel tape player and battery pack strapped to them.

❖ The Inescapable Digital World

Today we find ourselves in an age in which thousands of songs can be stored, with reasonable fidelity, on a digital player that disappears in your hand. We have digital shortwave radios that don’t even have knobs or dials that play great rings around the venerable old boat anchors of “the old days.” We have digital cell phones that have built-in cameras that take better pictures than many old 35 mm film cameras (and can do motion and sound and deliver them instantly to the other side of the world!).

Some of today’s digital technology hasn’t even been tried to its full potential. Doug Smith W9WI, MT’s Broadcast Bandscan columnist, reminds us that IBOC transmissions, once given full rein of the AM band, could make AM band DXing most interesting. In the few experiments that I’ve done listening to DX AM HD-Radio digital broadcasts from several hundred miles away, IBOC audio is truly amazing. And to think that what I was hearing was only 500 watts of a 50,000 watt station! If the AM band were to switch tomorrow to the IBOC standard (and everyone had an HD receiver, of course), things on that band would be decidedly different.

Decades ago, when satellite TV first began, millions sprung for high-ticket 10 foot dishes hooked to analog receivers to be able to see what they couldn’t see anywhere else, un-

less they lived in a cabled neighborhood. Now, two-foot dishes with no moving parts pull down hundreds of digital channels, many in high definition. Today’s satellite TV systems are basically given away if you’ll just sign up for one of their programming packages. But, it wasn’t the end of the satellite TV hobby. As reported often in this magazine, satellite TV hobbyists are tuning in to hundreds of international broadcasts from all over the world for free on complete digital receiver systems costing less than a decent LNA did on an old-style C-band dish: about \$200.

I recently heard something I had never heard before on the shortwave bands: A music program in stereo! I was using a Newstar DR111 shortwave receiver (not yet FCC certified for sale in the U.S.), which is a small, digital shortwave radio made in China and sold in Europe for about \$200. Though the fidelity from the very small speakers

wasn’t great, the audio was clearly in stereo and without any static. It was a revelation that such great audio could be found on the shortwave bands. What’s more, while I had the radio, the manufacturer sent me links to do a firmware update to correct a few glitches and improve reception, a real advantage for digital sets, something you can’t do with an analog receiver.

More than ten years ago satellite radio answered a call to deliver hundreds of digital channels of music, news, sports and entertainment to the tens of millions of daily commuters who lacked much choice in what they could hear locally. Suddenly, millions of tiny little, cube-shaped antennas were sprouting up on cars everywhere. Now, those antennas are part of the onboard electronics package you get when you buy a car that includes a GPS receiver (who could have imagined!). While many are happy with the

arrangement, others find the channel lineup limited. They have found ways to stream programming through their digital smartphones and listening to an infinitely greater programming lineup. Car manufacturers noticed and offer Internet radio in-dash in 2012 models.

To show how times have really changed, today’s cars feature “old-fashioned” satellite radio and in-dash HD-Radio as well as Internet Radio (oh yeah, most still have a built-in CD player). What more could anyone possibly want for audio reception in a car? Instead of all those impossible Rube Goldberg lash-ups I’ve tried throughout the years to get some variety into my car audio, new cars show that the digital future is already here.

❖ New and Improved TV Sets

But, what about inside the house? Those of us “cord-cutters” who got tired of paying ever-increasing monthly fees for cable and satellite TV have found a nearly perfect solution in today’s latest TV sets. Most people (including myself) bought HDTV sets prior to the switch from analog to digital TV in 2009. The new sets were nice; they had expansive screens, a thin profile and connected nicely to home stereos for a more theater-like experience, though

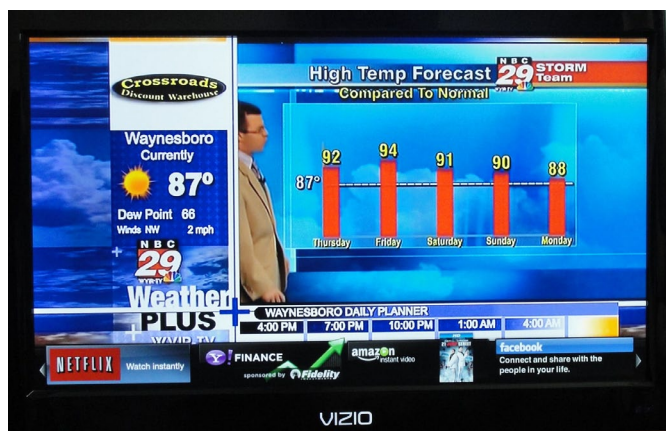

Vizio 26” HDTV/monitor/WiFi set. This TV works great as a monitor for your smaller laptop screen. With a built-in HDTV receiver; it does a great job for Over-the-Air TV. But, wait, there’s more! With built-in WiFi it also streams a variety of Internet TV sources including Netflix, Hulu, YouTube, Facebook and more. (Courtesy: Author)

they were way more expensive than we would like them to have been. Today, manufacturers have added built-in WiFi that lets you stream Internet program sources directly through your home router and broadband Internet connection. And, they've done so at ever cheaper prices.

A few months ago my wife and I were looking for a bigger monitor for her laptop. We looked online and found lots of pricey products. Later, I was in a nearby discount store and found myself staring at the wall of TV sets that ranged from 55 inches to 26 inches with prices to match. Down among the smaller, lower priced sets I saw a something that intrigued me. It was a 26 inch set made by Vizio, a new brand to me, that had a large number of connectors on the back including HDMI ports that could easily hook up to most laptops. It had a built-in Over-the-Air (OTA) tuner and could display 480, 720 or 1080i resolution from a variety of sources including an outboard DVD player. It also had built-in WiFi for a wireless connection to a home router. But, what really astounded me was the price: \$250. While that particular 26 inch model is no longer available, a 32 inch version has replaced it and the prices is still \$250! This newer set also has more Internet apps available, including Pandora, the radio service you control yourself.

One of the few drawbacks to this set has to do with the logistics of installing speakers. In order to make the set as minimal as possible, Vizio uses very small and very poor-sounding speakers that simply don't do justice to the quality of the picture. To see a 1080i full-screen image and hear the ear-grating audio takes a little something away out of the experience. I remedied the situation by routing the audio through a Tivoli Model One radio which makes all the difference. Taking the audio from the audio-out jack on the TV to the auxiliary input jack on the Tivoli lets me switch from FM to TV audio. Pandora will sound 100 per cent better that way too!

Streaming video through the TV couldn't be easier. The set finds your wireless router, logs in and updates itself. Once you establish an account with Netflix, for example, you're ready to start watching TV the way you want it. I can watch HD over-the-air or switch to Netflix and watch thousands of recently released movies, current as well as vintage TV series', documentaries, you name it. A monthly fee, starting at \$8 per month, let's us stream as much as our broadband service allows. Of course, as usual there's a hierarchy to movie and TV series availability. You won't be able to watch the very latest theater releases or TV shows. But, if you have any patience at all, you'll get over it.

Don't want to spring for a new TV after you just bought one that works just fine, but it doesn't have WiFi connectivity? Not to worry; Vizio offers their CoStar (\$100) that connects to your current TV and links wirelessly to your whole-house wireless router to provide the same Internet streaming capability to nearly any set. It has its own remote control to make things even easier.

❖ The Price of Progress

Of course, all this great technology isn't free. But, unlike DISH Network, DirecTV or other



Toyota brings the future of digital automotive audio to you today with an in-dash configuration that includes AM/FM/XM-Sirius/CD/HD-Radio/WiFi. Who could want more? There isn't any more! (Courtesy: Toyota)

cable services, which have constantly increasing subscription fees, you can pretty much limit the amount of money you sink into your entertainment habit. More importantly, you don't have to pay for channels you never watch.

Most people are on some sort of cable-TV service that will let them pay for their broadband Internet service by itself. Others will force you to buy it in a "bundle," which aptly describes the amount of money these companies make with such practices.



Vizio's CoStar (\$100) turns your "old-time" digital TV into a streaming TV by linking it to your whole-house network router. It even has its own remote control. (Courtesy: Vizio)

If you're not on a cable service you're not out of luck. There are several alternatives including satellite broadband, which is often so expensive that it is no more of a deal than cable or satellite-TV and rarely delivers speeds necessary for video streaming. At our house we use a wireless broadband modem that costs about \$40 per month for the service and delivers about 1.5 Mb/s, not fast enough to stream full 1080i video, but certainly good enough for 720. Many other similar Internet services are cheaper, some are more expensive. Most will include the broadband modem with the service. Add to that the \$8 per month for Netflix, and for less than \$50 per month, we have full Internet access for the computer, laptop and tablet, as well as a huge assortment of programming to choose from via the Vizio TV set.

Once again, instead of trying to stream video through a laptop onto a TV, the Vizio does it all for

us. Combining selections from over a dozen OTA network channels, and the vast Netflix library, works for us. You do want to pay attention to the amount of video streaming you use because you could soon find yourself running out of bandwidth and be forced to buy extra, usually a \$10 per GB.

There's a certain irony to watching TV in this fashion. While we're using the very latest technology to do something undreamed of even ten years ago, we sometimes find ourselves watching the very shows that were on TV when no one had cable TV, Sputnik was the only satellite in the sky, and a social network was a weekly bridge or poker game.

CC WiFi Internet Radio



**Receive Your Favorite Stations*
Over 18,000 Available Worldwide**

- Excellent, Clear Audio
- Works on Any Broadband Signal
- Real, MP3, WMA Formats
- 99 Presets
- Wireless or Direct Connection via Ethernet Jack, Line-Out, Headphone, Signal Strength Indicator
- No Subscription Fee

* Your favorite station must stream audio. You must have broadband internet service.

\$139⁹⁵

C. CRANE

Free Catalog

800-522-8863 • ccrane.com



PROGRAMMING SPOTLIGHT

WHAT'S ON WHEN AND WHERE?

Fred Waterer

fredwaterer@monitoringtimes.com

www.doghousecharlie.com/radio

Weekend Shortwave Radio

Everyone has busy schedules these days. The Internet and all its associated technology far from simplifying our lives seem to have just made them busier. Or perhaps we just have more things to occupy us! Whatever the reason, sometimes it is just nice to step away from all the technology and go old school. So Sundays, I like to shut down the computer (or at least step away from it), go outside or downstairs, and fire up the shortwave radio, spin the dial and make notes with pen and paper. I'm not sure whether that makes me "old school" or just old. Either way, here's what one might hear on a (relatively) quiet weekend evening.

❖ Sunday Listening Highlights

Radio Romania International, from the land that gave us the legend of Dracula, the delightful Nadia Comaneci and the not so delightful Nicolae Ceaucescu, continues to blast powerful signals towards North America every night. In August 9700 kHz in French at 0100 UTC and 11795 kHz in Spanish at 0200 UTC, provided a great opportunity to both listen to RRI, and practice one's language skills! Of course, one can also listen to RRI in English. 9700 kHz at 0000 UTC is a particularly good choice or online at www.ri.ro.

What can one hear on RRI? The schedule is quite varied. Each broadcast begins with a news bulletin. On Sundays, one can hear the following program features: Inside Romania, which introduces the listener to Romania and the Romanians. An August edition featured the *Truffle Hunters of Romania*, looking at the "food of kings." Truffles are very valuable as well as being a culinary delight. A Romanian TV chef then explained how he made "truffle oil" and used it to prepare a dish. Inside Romania was then followed by *Sunday Studio*, which, being broadcast during the Olympics, featured an interview with the Romanian female gymnastics coach, followed by *Listeners' Letterbox* and a *Philately Corner*. Other features that take turns appearing in this spot from week to week include *Romanian Without Tears* (a Romanian language course), *Living Romania*, *Visit Romania*, *All That Jazz* and *The Cooking Show*.



On the subject of practicing one's language skills, recently I have been trying to justify all the money I spent on tuition in the 1980s and have been listening to the Russian Service of the **Voice**

of Russia. This season, the Voice of Russia has been particularly well heard, in English on 9665 kHz and 9800 kHz, and in Russian on 9435 kHz. www.ruvr.ru

The **Russian Service** is similar to the **Voice of Russia English Service** but with a lot less music. There do not seem to be a lot of music programs in the schedule (assuming one can trust Google Translate), but in almost every broadcast hour one can hear a few Russian songs, which might appeal to an older audience. The Germans might call them Schlager, music that appeals to a pre-Rock and Roll listener. But that is just an opinion. What the station does have is a solid schedule of current affairs programming. Listening in the evening over a few days, many current affairs discussion programs were noted with participants who were often very passionate. I couldn't always follow the discussions, but as my Russian prof would tell me I will "keep listening and figure it out." Good advice!



Another radio station, which continues to provide both a strong signal, and very enjoyable musical programming, is the **Voice of Croatia** (Glas Hrvatske) on 9925 kHz via transmitters in Germany. Most evenings one can listen for several hours to the unique and lively music from this Balkan nation. Listening to the music from Croatia is like sitting in a cafe on the Dalmatian Coast, sipping a cool drink and enjoying the sunset. Best heard around 0200 UTC, try any evening for this treat from the Mediterranean.

To the southeast of Croatia is Turkey. The **Voice of Turkey** in Spanish can be heard from 0100-0200 on 9770 kHz. Turkey is an interesting country, straddling the line between East and West, Europe and the Middle East, the secular and the religious. Although Spanish is not one of my stronger points, I still enjoy listening to this program, especially when they play music. At about 0130 UTC on August 6, some really funky music was heard, a fusion of Western and Middle Eastern styles, which made me stop what I was doing and take note. Just because one may not understand the language being used in a given program doesn't mean that one can't enjoy the content, and anyway, music is an international language.

Some radio stations did not get the memo about the decline of shortwave radio. Any given evening one can trip over several frequencies in both English and Chinese from **China Radio International** (CRI). While China and Taiwan duel occasionally across the Formosa Strait, their radio stations, China Radio International and



Radio Taiwan International (RTI), duel 10 kHz apart on the 31-meter band. CRI can be heard on 9690 kHz while RTI can be heard on 9680 kHz. At 0200, CRI can be heard in a Chinese dialect. While I have no real clue what they are talking about, the booming signal is nevertheless interesting to listen to. Whatever they were talking about, there was some great background music as they talked. CRI certainly has a more sophisticated and nuanced approach to radio programming than they had during the Cold War. This seems to be true in all language departments.

Radio Taiwan International usually wins my allegiance in this particular radio dispute. The Sunday night programming from RTI has always been both fun, entertaining and laid back. On this particular evening, the program was talking about what sort of food Taiwanese people miss when they go abroad. One suggestion was an Oyster Omelet. The program presenters at RTI are a bit less formal and younger sounding, and while they are very professional, they seem to have much more fun than their mainland counterparts.

WYFR is another station that isn't quite what it used to be. Also known as Family Radio, WYFR is in Okeechobee, Florida. Tuning around 0200 UTC on 6115 kHz, the unmistakable voice of the man who reads the *Family Bible Reading Fellowship* was heard. I am not really sure who this man is (was?) but his voice is very distinctive and has been heard on WYFR since the 1970s, reading the Bible. This feature is much more useful than Brother Harold Camping's apocalyptic predictions.

The WYFR website seems to wish it could just forget Brother Camping's whole end of the

world prediction (his second swing and a miss at such a prediction). There is a letter posted online, which tries to put a positive spin on things, implying that at least the failed prediction got people thinking about the end times and their own relationship with God. One might also assume that it drove just as many people away from such thoughts. Nevertheless, Camping was heard on the air at midnight UTC, introduced as President and General Manager of Family Radio. He delivered a talk of approximately 10 minutes, sounding like he has clearly not recovered from his stroke. WYFR English programming can be heard daily from 2230 to 0300 UTC on 6115 kHz. Most programming consists of Christian music, which is really quite pleasant to listen to. In my younger days I would often listen to Family Radio for hours at a time as background music. It seems that one can still do this. Not a bad thing at all. WYFR can also be heard in Spanish at 0200 UTC on 11580 kHz.

One never knows what one might hear during a random spin around the shortwave bands. At 0230 UTC **Radio Japan's** Japanese Service was noted on 11935 kHz. On this particular occasion, a man in the studio was talking to a child, probably by telephone. It caught my interest, just because of the tone of the conversation. I have no idea what they were talking about, but it was very endearing. This child was being made to feel very important, and the interviewer was obviously enjoying the child's very excited and enthusiastic answers. You could hear a smile in his voice. It was a very random event but perhaps the highlight of my night.

These are just a few programs picked at random from a Sunday night session with a shortwave radio. While many stations have gone, there is still a lot to hear out there. Let us know what you are hearing!

❖ Weekday Listening Highlights

While watching the recent Olympics from London it occurred to me that people who participate in hobbies such as shortwave listening and stamp collecting have a better than average knowledge of world geography. Maybe I am just odd, but as the athletes of each nation marched into the stadium, I would associate them with a radio station from their respective countries. Or maybe I am just radio obsessed!

Later I was watching a particularly poor boxing match (which reminded me why I don't like boxing). The Cuban boxer was clearly robbed in the match, the crowd knew it, the Canadian announcer knew it, the Cuban coaches knew it, but the judges...not so much. I decided to switch off the television and turned on my shortwave radio and "spun the dial." It was much more satisfying.

One of the first stations I tuned in turned out to be none other than **Radio Habana Cuba**. I happened to tune in as Arnie Coro was starting his DX Program called *DXers Unlimited*. I have to admit that I rarely tune in to this program but on



this particular night it was very informative. Arnie was discussing the role of radio during a recent hurricane and how various hams had become conduits of information about the state of the country. Arnie's program served as a reminder to listen to shortwave during events such as hurricanes and other natural disasters. If you would like to give it a listen, Cuba can be heard on UTC Mondays (Sunday evenings in the Eastern Time Zone) at 0115, 0215, 0315, 0415, 0515 and 0615 UTC on 6000 and 6050 kHz.

Later in the evening I checked back a few times and heard some always-lively music as well as the usual (sometimes but not always heavy-handed) politics. Radio Habana Cuba is a reliable source of entertainment almost any night of the week. Enjoy!

WEWN is an easy catch most afternoons with a wealth of programming from a Catholic viewpoint. One can hear a series of daily phone-in programs weekdays from 1700 UTC on 15610 kHz, beginning with *The Dr. Is In*, a show answering questions about personal problems from a spiritual perspective. More often than not the answers involve a return to Church and prayer. Dr. Ray Guarendi and Dr. Colleen Kelly Mast host the program. Think of it as a Catholic Dr. Laura program with advice on dealing with life issues. I happened to listen when Dr. Mast seemed to be flying solo, but I found her to be competent and not terribly judgmental. EWTN *Open Line*, a two-hour phone-in program, follows *The Dr. Is In* at 1900 UTC with a different host each day. John Martignoni covers apologetics on Mondays; Barbara McGuigan discusses chastity and pro-life issues on Tuesdays. **Wednesdays** Fr. Mitch Pacwa addresses Bible and Church questions and then on **Thursdays** Patrick Madrid tackles the Church and the world. Finally on **Fridays** Colin Donovan answers questions about theology.

A lot of programming here leans conservative. I like to hear all sides of a question, seeing whether the arguments persuade me that I am right or wrong. As a Catholic radio station it is pretty much a given that the message is going to have some biases. But you might find that some of the programming is not only interesting, but also entertaining and informative. And of course, any time one of the programs featuring Mother Angelica is on, I am going to listen. People who know her have told me that in person she is no different than she appears on the air. She is funny, serious, and very compassionate. As a side note, here in Southern Ontario EWTN Television



comes with my cable package. Many of the programs heard on the radio are also seen on TV. Usually on a Saturday night there is a movie of some sort, with a Catholic theme, such as the life of Pope Paul VI or Pope John Paul II. Although I am not a Catholic, I often stop on an EWTN program as I surf by. The quality of both the television and radio programming is top notch.

❖ Recommended Listening

Radio New Zealand International and **Radio New Zealand National – Music 101**. While perusing the Radio New Zealand schedule over the past few years I have often noticed the program *Music 101* but never actually listened to it...until now. Wow, what a treat! Tuning around in the early hours of a Saturday, I came across Radio New Zealand International. While it was around midnight here, it was well into the afternoon in New Zealand. RNZI rebroadcasts Radio New Zealand National programming for much of the weekend.

Music 101 is a weekly Saturday afternoon program that's similar to **CBC Radio One's** *Definitely Not the Opera*, or **BBC Radio 2's** former three-hour *Mark LaMarr Show*, with a local New Zealand vibe. Each week, Kirsten Johnstone and Emma Smith present a three-hour excursion into what is new and hot on the music scene in New Zealand and around the world.



Live studio sessions, recorded concerts, interviews and documentary reports make this a comprehensive, and very entertaining survey of the music industry in New Zealand. The focus is of course on New Zealand music, but you will hear music from around the world. Like *Mark LaMarr* there is often a featured artist or an informal in-studio performance. Interviews with local emerging acts and more established performers are also featured. Music documentaries from New Zealand and abroad can also be heard and at 4:10 pm (local) each week "we broadcast one of these programmes: *Musical Chairs*: profile of a local music personality, era or scene; *Live Music*: recordings of great performances; *Music Features and Documentaries*: international and NZ-made programmes on a range of music-related topics." (*Music 101* webpage)

The program is heard every Saturday from 2-5 pm local New Zealand time, (0100-0400 UTC Saturday) on 15720 kHz shortwave, or online at www.radionz.co.nz/national.

THE QSL REPORT

VERIFICATIONS RECEIVED BY OUR READERS

Gayle Van Horn, W4GVH

gaylevanhorn@monitoringtimes.com

http://mt-shortwave.blogspot.com

Twitter @QSLRptMT



QSL Contact Updates

High summer static has subsided and radio conditions have improved. Africa, South America and Europe are fading in earlier. Twilight and night time patterns have improved and will continue to do as longer darkness paths provide an extended time to bandscan.

In case reception reports are in your future, this month an updated station contact list will provide you the latest to assist in your QSL quest. Veri-signers, QSL Managers, email, web URLs and postal addresses can change frequently. Staying up to date is a must in the QSL game.

BELARUS

Radio Belarus. Fyodor Parfenka, Chief Engineer *radio_belarus@tvr.by* Address: vul. Cyrvoñaia 4, 220807 Minsk, Belarus **www.tvr.by**

BELGIUM

Pur Radio 1. *purradio@skynet.be* **www.radio770.de/**

BOLIVIA

Radio Santa Cruz. Yolanda Marco Escobar, Secretaria de Direccion. Address: Instituto Radiofonica Fe y Alegria, Casilla 672, Santa de la Sierra, La Paz, Bolivia. *direccion@irrfabolivia.org*

BRAZIL

Radio 9 de Julho. Address: Rua Manoel Arzão 85, São Paulo 2730-030, Brasil. *radio@radio9dejulho.com*

Radio Clube do Para. Camilo Centeno, Director Geral. Address: Avenida Almirante Barroso 2190, Barrio Marco, CEP-66095-000 Belem, Para, Brasil. **www.clubedopara.com.br/**

Radio Cultura Para. Address: Avenida Almirante Barroso 735, Barrio Marco, CEP-66093-020 Belem, Para, Brasil.

Radio Educadora de Braganca. Padre Mauricio Soares de Sousa, Presidente. *fundacaeducadora@uol.com.br* Address: Rua 13 de Maio s/n CEP 68600-000 Braganca, Brasil. **www.educadora.com.br**

Radio Guaruja Florianopolis, Carlos Alberto Silva, Executivo de Contas, Address: End. Rua Nunes Machado 94, Ed. Tiradentes 8 e 10 andares, CEP 88010-460 Florianopolis, SC Brasil.

Radio Imaculada Conceição de Campo Grande Maria Sanmarchi, Coordenadora da Produção. *580am@miliciadaimaculada.org.br* **www.miliciadaimaculada.org.br**

Radio Inconfidencia. Marcus Starling, Director Tecnico. Address: Av. Raja Gabaglia 1666, Jardim Luxemburgo, Belo Horizonte, Minas Gerais 30441-194, Brasil.

Radio Itatiaia. Severino Carneiro, Gerente Técnico. Address: Rua Itatiaia 117, Bonfim, 31210-170 Belo Horizonte MG, Brasil.

Radio Nacional da Amazonia, Miss Tais Ladeira de Medeiros, Gerente. Address: SCR N 702/2 Bl. B-Ed Radiobras, subsolo, CEP 70323-900 Brasilia, DF, Brasil. **www.radio.bras**

Radio Nacional da Brasilia, Mrs. Mariane Ferreira Oliveira Portela.

Radio Novo Tempo, Ellen Ramos, Journalist & Presente. Address: Rodovia SP 66, Km 86, n 5876, Jardim São Gabriel, Jacarei, SP, Brasil.

Super Radio Rede Boa Vontade. Vera Carpes Quednau, Coordenadora de Programação. Address: Legiao da Boa Vontade (LBV), Super Radio Boa Vontade, Avenida São Paulo 722, Barrio Navegantes, Geraldo, CEP 90230-160 Porto Alegre, RS Brasil.

Voz Missionaria. Luiz Carlos Machado, Diretor. *luizgideoe@hotmail.com* (or) Cesino Bernardino, Presidente (or) Revel Bernardino, Vice Presidente. Address: Rua Joaquim Nunes 244, Centro, CEP 88340-000 Camboriu, SC Brasil. **www.gideos.com.br/**

CANADA

CHU-Time/Frequency Station. Bill Hoger, Technical Officer. Address: Institute for National Measurement

Standards, National Research Council of Canada (NRC-INMS), 1200 Montreal Road, Bldg. M-36, Ottawa, Ontario, K1A 0R6, Canada. **www.nrc.gc.ca**

COLOMBIA

Salem Stereo, **www.salemstereo.com** *salemstereo@hotmail.com*

CLANDESTINE

Democratic Voice of Burma via Yerevan, Armenia. Nanthikarn Khetcharatsaeng, Executive Administrative Officer *lp@dvb.no*

Domo I Viti, Address: 9 Florence Terrace, Rosewater, Adelaide 5014, Australia *fijidemocracy@hotmail.com*

Radio Biafra London. *info@radiobiafralondon.com*

Sawtu Linjila/Voice of the Gospel. Charles Mbayanga *mbayangacharles@yahoo.fr*

Address: Boite Postal 02, Ngaoundéré, Cameroon **www.lutheranworld.org**

Sound of Hope Radio International. Address: 6-4, Lane 84, GuoTai Street, North District, Taichung 404, Taiwan.

http://sohnetwork.com/

Sudan Radio Service. Mrs. Emily Ekiilu *ekiilu@sudanradio.org* (or) *srs@sudanradio.org*

www.sudanradio.org/

Voice of Eritrea. Samuel Andeberhan *samiande@yahoo.com* **www.mahta.net/**

CUBA

Radio Habana Cuba. Lourdes Lopez, Directora. *radiohc@enet.cu* (or) *infohc@enet.cu* Address: Apartado 6240, La Habana 10600, Cuba **www.radiohc.cu**

DIEGO GARCIA

Armed Forces Network/AFRTS, *QSL@dodmedia.osd.mil*

FRANCE

Polskie Radio via Issoudun, France. Aleksander Kropiwnicki, Editor. Address: P.O. Box 46, 00-977 Warsaw, Poland. **www.polskieradio.pl**

GERMANY

Christliche Wissenschaft, *csradiod@gmx.de*

HCBJ Global. Address: c/o Shortwave Radio, P.O. Box 8025, 32736 Detmold, Germany

Radio Free Asia relay via Lampertheim, Germany. *qsl@rfa.org* Address: 2025 M. Street NW, Suite 300, Washington, DC 20036 USA. **www.techweb.rfa.org**

Radio Öömrang. Lothar Kuchenberg *QSL-Shortwave@media-broadcast.com*

GUATEMALA

Radio Verdad. Dr. Edgar Amilcar Madrid. Address: Apartado Postal 5, Chiquimula, Guatemala. *radio.verdad.em@gmail.com*

INDIA

All India Radio-Bangalore. Mr. T. Rajendiran, Superintending Engineer, Address: All India Radio, Super Power Transmitters, Yelahanka New Town, Bengaluru 560065, Karnataka, India *rajendiran37@yahoo.com*

ITALY

IBF Time Signal Station, *qsl@radiomaria.org*

MICRONESIA

V6MP Cross Radio, Sylvia Kalau, Station Manager. *phhnpei@pmapacific.org* Address: Pacific Missionary Aviation, Radio Station, P.O. Box 517, Kolonia, Pohnpei State FSM 96941 **www.pmapacific.org/**

MOLDOVA

Radio PMR. Kirsa Anatoly Alekseyevich. Address: Radio Pridnestrovie, MD-3300, Tiraspol, Pravada Str. 31, Moldova. **www.pmr.org**

MONGOLIA

Voice of Mongolia. Enkhmaa Zorig, Mail Editor *vomen@yahoo.com*

(or) Bolorchimeg, E. Address: P.O. Box 365, Ulaanbaatar 13, Mongolia. **www.vom.mn**

PAKISTAN

Radio Pakistan. Ifkhar Hussain Malik, Deputy Controller *fmcell@radio.gov.pk*

(or) *info@radio.gov.pk* Address: Broadcasting House, Constitution Avenue, Islamabad 4400, Pakistan. **www.radio.gov.pk**

PAPUA NEW GUINEA

Radio Fly. Kabura J. Momo (or) James Kaltobie. Address: Radio Fly, Ok Tedi Mining Limited, P.O. Box 1, Tabubil, Western Province, Papua New Guinea

Wantok Radio Light. Dorish Asang. *admin@wantokradio.org* (or) *qsl@wantokradio.org* Address: Papua New Guinea Christian Broadcasting Network, P.O. Box 1273, Port Moresby NCD, Papua New Guinea. **www.wantokradio.org**

PERU

Radio JPJ Del Perú. **www.radiojpi.com**

Radio Mosoj Chaski. Address: Abaroa No. 254, entre General acha y Santivanez, Cochabamba, Peru (or) Casilla 4493, Cochabamba, Peru

PORTUGAL

Deutsche Welle relay via Sines. *info@dw-world.de*

RUSSIA

Radio St. Petersburg via Radio Rossii. Mikhail Timofeyev, QSL Manager. *timofeyev@sp.ru* (or) *dxcorner@wonder.ru* Address: SPBRC Technical Department, Ulitsa Akademica Pavlova 3, RU-197022 St. Petersburg, Russia

Vatican Radio via Novosibirsk, Russia. Sergio Salvatori, Frequency Management. Address: Piazza Pia 3, 1-00120 Vatican City. **www.radiovaticana.org**

SOMALILAND

Radio Hargheisa. Address: Konsularische Vretretung of the Republic of Somaliland, Zedern Weg 6, DE-50127 Bergheim, Germany. *radiohargheisa@live.com*

SOUTH AFRICA

Channel Africa. Lungi Daweti, Program Manager *dawetij@sabc.co.za* Address: P.O. Box 91313, Auckland Park 2006, South Africa **www.channelafrica.co.za**

SRI LANKA

Sri Lanka Broadcasting Corporation via Tricomalee. Address: P.O. Box 574, Colombo 7, Sri Lanka. **www.slbc.lk**

SWAZILAND

Trans World Radio Africa. S. Stavropoulos. Address: P.O. Box 64, Manzini, Swaziland. **www.twrafrica.org/**

THAILAND

Radio Free Europe/Radio Liberty relay. Address: Thailand Transmitting Station, P.O. Box 99-A, Muang, Udong, Thailand 410000, Thailand. *managerthailand@tha.ibt.gov*

UNITED KINGDOM

Polskie Radio via Wooferton relay. Slawek Szeps. Address: Al. Niepodleglosci 77/85, 00-977 Warszawa, Poland. **www.polskieradio.pl**

UNITED STATES

Voice of America via Greenville. Address: 3919 VOA Site B Road, Greenville, NC 27837 USA.

UZBEKISTAN

IBRA Radio via Tashkent. *info@ibra.se* Address: IBRA Radio, SE-141 99, Stockholm, Sweden. **www.ibra.se**

VIETNAM

Voice of Vietnam. Address: 58 Quan Su Street, Hanoi, Vietnam. **www.vovnews.vn**



HOW TO USE THE SHORTWAVE GUIDE

0000-0100 twhfa USA, Voice of America 5995am 6130ca 7405am 9455af
 ① ② ⑤ ③ ④ ⑥ ⑦

CONVERT YOUR TIME TO UTC

Broadcast time on ① and time off ② are expressed in Coordinated Universal Time (UTC) – the time at the 0 meridian near Greenwich, England. To translate your local time into UTC, first convert your local time to 24-hour format, then add (during Daylight Savings Time) 4, 5, 6 or 7 hours for Eastern, Central, Mountain or Pacific Times, respectively. Eastern, Central, and Pacific Times are already converted to UTC for you at the top of each hour.

Note that all **dates**, as well as times, are in UTC; for example, a show which might air at 0030 UTC **Sunday** will be heard on **Saturday** evening in America (in other words, 8:30 pm Eastern, 7:30 pm Central, etc.).

Not all countries observe Daylight Saving Time, not all countries shift at the same time, and not all program scheduling is shifted. So if you do not hear your desired station or program, try searching the hour ahead or behind its listed start time.

FIND THE STATION YOU WANT TO HEAR

Look at the page which corresponds to the time you will be listening. English broadcasts are listed by UTC time on ①, then alphabetically by country ③, followed by the station name ④. (If the station name is the same as the country, we don't repeat it, e.g., "Vanuatu, Radio" [Vanuatu].)

If a broadcast is not **daily**, the days of broadcast ⑤ will appear in the column following the time of broadcast, using the following codes:

<u>Codes</u>	
s/Sun	Sunday
m/Mon	Monday
t	Tuesday
w	Wednesday
h	Thursday
f	Friday
a/Sat	Saturday
occ:	occasional
DRM:	Digital Radio Mondiale
irreg	Irregular broadcasts
vl	Various languages
USB:	Upper Sideband

CHOOSE PROMISING FREQUENCIES

Choose the most promising frequencies for the time, location and conditions.

The frequencies ⑥ follow to the right of the station listing; all frequencies are listed in kilohertz (kHz). Not all listed stations will be heard from your location and virtually none of them will be heard all the time on all frequencies.

Shortwave broadcast stations change some of their frequencies at least twice a year, in April and October, to adapt to seasonal conditions. But they can also change in response to short-term condi-

tions, interference, equipment problems, etc. Our frequency manager coordinates published station schedules with confirmations and reports from her monitoring team and **MT** readers to make the Shortwave Guide up-to-date as of one week before print deadline.

To help you find the most promising signal for your location, immediately following each frequency we've included information on the target area ⑦ of the broadcast. Signals beamed toward your area will generally be easier to hear than those beamed elsewhere, even though the latter will often still be audible.

Target Areas

af:	Africa
al:	alternate frequency (occasional use only)
am:	The Americas
as:	Asia
ca:	Central America
do:	domestic broadcast
eu:	Europe
me:	Middle East
na:	North America
pa:	Pacific
sa:	South America
va:	various

MT MONITORING TEAM

Gayle Van Horn
 Frequency Manager
gaylevanhorn@monitoringtimes.com

Larry Van Horn, MT Asst. Editor
larryvanhorn@monitoringtimes.com

Additional Contributors to This Month's Shortwave Guide:

Thank You to ...

BCL News; BDX Club; Cumbre DX; DSWCI/DX Window; Hard-Core DX; DX Re Mix News 737-742; BCDX/WWDX/Top News.

Adrian Petersen/DBS 2012; Alokesh Gupta, New Delhi, India; Brenda Constantino/Florida; Eike Bierwirth, Germany; Georgi Bancov, Bulgaria; Ivo Ivanov, Bulgaria; Ron Cesarek, FL; Sean Gilbert UK/WRTH 2012; Wolfgang Bueschel, Stuttgart, Germany.

SHORTWAVE BROADCAST BANDS

kHz	Meters
2300-2495	120 meters (Note 1)
3200-3400	90 meters (Note 1)
3900-3950	75 meters (Regional band, used for broadcasting in Asia only)
3950-4000	75 meters (Regional band, used for broadcasting in Asia and Europe)
4750-4995	60 meters (Note 1)
5005-5060	60 meters (Note 1)
5730-5900	49 meter NIB (Note 2)
5900-5950	49 meter WARC-92 band (Note 3)
5950-6200	49 meters
6200-6295	49 meter NIB (Note 2)
6890-6990	41 meter NIB (Note 2)
7100-7300	41 meters (Regional band, not allocated for broadcasting in the western hemisphere) (Note 4)
7300-7350	41 meter WARC-92 band (Note 3)
7350-7600	41 meter NIB (Note 2)
9250-9400	31 meter NIB (Note 2)
9400-9500	31 meter WARC-92 band (Note 3)
9500-9900	31 meters
11500-11600	25 meter NIB (Note 2)
11600-11650	25 meter WARC-92 band (Note 3)
11650-12050	25 meters
12050-12100	25 meter WARC-92 band (Note 3)
12100-12600	25 meter NIB (Note 2)
13570-13600	22 meter WARC-92 band (Note 3)
13600-13800	22 meters
13800-13870	22 meter WARC-92 band (Note 3)
15030-15100	19 meter NIB (Note 2)
15100-15600	19 meters
15600-15800	19 meter WARC-92 band (Note 3)
17480-17550	17 meter WARC-92 band (Note 3)
17550-17900	17 meters
18900-19020	15 meter WARC-92 band (Note 3)
21450-21850	13 meters
25670-26100	11 meters

Notes

- Note 1 Tropical bands, 120/90/60 meters are for broadcast use only in designated tropical areas of the world.
- Note 2 Broadcasters can use this frequency range on a (NIB) non-interference basis only.
- Note 3 WARC-92 bands are allocated officially for use by HF broadcasting stations in 2007 WRC-03 update. After March 29, 2009, the spectrum from 7100-7200 kHz will no longer be available for broadcast purposes and will be turned over to amateur radio operations worldwide.
- Note 4

"MISSING" LANGUAGES?

A **FREE** download to MTXpress subscribers, the online MTXtra Shortwave Guide is 115+ pages of combined language schedules, sorted by time. Print subscribers: add the MTXtra SW Guide to your subscription for only \$11.95. Call **1-800-438-8155** or visit www.monitoringtimes.com to learn how.

0000 UTC - 8PM EDT / 7PM CDT / 5PM PDT

0000 0030	Egypt, R Cairo	9965na	
0000 0030	USA, BBG/Voice of America	7555as	
0000 0045	India, AIR/External Svc	6055as	9705as
		9950as	11670as 13605as
0000 0045 DRM	India, AIR/External Svc	9950eu	
0000 0045	USA, WYFR/Family R Worldwide	11650as	
0000 0056	Romania, R Romania Intl	9700na	11965na
0000 0100	Anguilla, University Network	6090na	
0000 0100	Australia, ABC NT Alice Springs	4835do	
0000 0100	Australia, ABC NT Katherine	5025do	
0000 0100	Australia, ABC NT Tennant Creek	4910do	
0000 0100	Australia, ABC/R Australia	12080pa	15160pa
		15240pa	15415pa 17795pa 19000pa
		21740pa	
0000 0100	Bahrain, R Bahrain	6010me	
0000 0100	Canada, CFRX Toronto ON	6070na	
0000 0100	Canada, CFVP Calgary AB	6030na	
0000 0100	Canada, CKZN St Johns NF	6160na	
0000 0100	Canada, CKZU Vancouver BC	6160na	
0000 0100	China, China R International	6075eu	
		6180as	7350eu 7415as 9570na
		11790as	11885as 15125as
0000 0100	Malaysia, RTM Kajang/Traxx FM	7295do	
0000 0100	Micronesia, V6MP/Cross R/Pohnpei	4755as	
0000 0100	New Zealand, R New Zealand Intl	15720pa	
0000 0100 DRM	New Zealand, R New Zealand Intl	17675pa	
0000 0100	Russia, VO Russia	9665va	9800va
0000 0100	Spain, R Exterior de Espana	6055na	
0000 0100	Thailand, R Thailand World Svc	15275na	
0000 0100	UK, BBC World Service	5970as	6195as
		7395as	9410as 9740as 12095as
		15335as	15755as 17685as
0000 0100	USA, Amer Forces Network/AFRTS	4319usb	
		5446usb	5765usb 7811usb 12133usb
		12759usb	13362usb
0000 0100	USA, FBN/WTJC Newport NC	9370na	
0000 0100 Sat/Sun	USA, WBCQ Monticello ME	5110am	
0000 0100	USA, WBCQ Monticello ME	7490am	9330am
0000 0100	USA, WEWN/EWTN Irontdale AL	11520af	
0000 0100	USA, WHRI Cypress Creek SC	5920va	
		7315ca	9860na
0000 0100	USA, WINB Red Lion PA	9265am	
0000 0100	USA, WTWW Lebanon TN	5755va	
0000 0100	USA, WWCR Nashville TN	4840eu	5935af
		6875af	9980eu
0000 0100	USA, WWRB Manchester TN	3185na	
		5050na	
0000 0100	USA, WYFR/Family R Worldwide	6145na	
		17580as	
0000 0100	Zambia, Christian Voice	4965af	
0030 0100	Australia, ABC/R Australia	17750as	
0030 0100	USA, BBG/Voice of America	7430as	
		9715as	9780as 11725as 12005as
		15205as	15290as 17820as
0030 0100 mtwhf	USA, WRMI/R Slovakia Intl relay	9955am	
0035 0045	India, AIR/Aizawl	5050do	7295do
0035 0045	India, AIR/Chennai	4920do	
0035 0045	India, AIR/Guwahati	4940do	
0035 0045	India, AIR/Hyderabad	4800do	
0035 0045	India, AIR/Imphal	4775do	
0035 0045	India, AIR/Port Blair/Andaman & Nicobar	4760do	
0035 0045	India, AIR/Shimla	4965do	6020do
0035 0045	India, AIR/Thiruvananthapuram	5010do	

0100 UTC - 9PM EDT / 8PM CDT / 6PM PDT

0100 0115 Sat	Canada, Bible Voice Broadcasting	9490as	
0100 0130	Vietnam, VO Vietnam/Overseas Svc	6175na	
0100 0200	Anguilla, University Network	6090na	
0100 0200	Australia, ABC NT Alice Springs	4835do	
0100 0200	Australia, ABC NT Katherine	5025do	
0100 0200	Australia, ABC NT Tennant Creek	4910do	
0100 0200	Australia, ABC/R Australia	12080pa	15160pa
		15240pa	15415pa 17750as 17795pa
		19000pa	

0100 0200	Bahrain, R Bahrain	6010me	
0100 0200	Canada, CFRX Toronto ON	6070na	
0100 0200	Canada, CFVP Calgary AB	6030na	
0100 0200	Canada, CKZN St Johns NF	6160na	
0100 0200	Canada, CKZU Vancouver BC	6160na	
0100 0200	China, China R International	6175eu	
		9410eu	9410eu 9470eu 9535as
		9570na	9580na 9675eu 11870as
		15125as	15785as
0100 0200	Cuba, R Havana Cuba	6000na	6050na
0100 0200	Malaysia, RTM Kajang/Traxx FM	7295do	
0100 0200	Micronesia, V6MP/Cross R/Pohnpei	4755as	
0100 0200	New Zealand, R New Zealand Intl	15720pa	
0100 0200 DRM	New Zealand, R New Zealand Intl	17675pa	
0100 0200	Russia, VO Russia	9665va	9800va
0100 0200	Taiwan, R Taiwan Intl	11875as	
0100 0200	UK, BBC World Service	7395as	9410as
		9740as	11750as 12095as 15310as
		15335as	15755as 17685as
0100 0200	USA, Amer Forces Network/AFRTS	4319usb	
		5446usb	5765usb 7811usb 12133usb
		12759usb	13362usb
0100 0200	USA, BBG/Voice of America	7430as	
		9780as	11705as
0100 0200	USA, FBN/WTJC Newport NC	9370na	
0100 0200	USA, KJES Vado NM	7555na	
0100 0200 Sat/Sun	USA, WBCQ Monticello ME	5110am	
0100 0200	USA, WBCQ Monticello ME	7490am	9330am
0100 0200	USA, WEWN/EWTN Irontdale AL	11520af	
0100 0200 m	USA, WHRI Cypress Creek SC	9605na	
0100 0200	USA, WHRI Cypress Creek SC	9840na	
		9860na	
0100 0200	USA, WINB Red Lion PA	9265am	
0100 0200 irreg	USA, WRNO New Orleans LA	7505am	
0100 0200	USA, WTWW Lebanon TN	5755va	
0100 0200	USA, WWCR Nashville TN	3215eu	4840na
		5890af	5935af
0100 0200	USA, WWRB Manchester TN	3185na	
		5050na	
0100 0200	USA, WYFR/Family R Worldwide	6145na	
0100 0200	Zambia, Christian Voice	4965af	
0120 0200 mtwhfa	Sri Lanka, SLBC	6005as	9770as 15745as
0130 0200 twhfasalbania	R Tirana	7425na	
0130 0200	Myanmar, Thazin BC Sta	6030do	
0130 0200 mtwhfa	USA, BBG/Voice of America	7465ca	
		9820sa	
0140 0200	Vatican City State, Vatican R	9580as	11730as

0200 UTC - 10PM EDT / 9PM CDT / 7PM PDT

0200 0230	Thailand, R Thailand World Svc	15275na	
0200 0230	USA, KJES Vado NM	7555na	
0200 0230 Sat	USA, WBCQ Monticello ME	5110am	
0200 0300	Anguilla, University Network	6090na	
0200 0300 twhfa	Argentina, RAE	11710am	
0200 0300	Australia, ABC NT Alice Springs	4835do	
0200 0300	Australia, ABC NT Katherine	5025do	
0200 0300	Australia, ABC NT Tennant Creek	4910do	
0200 0300	Australia, ABC/R Australia	12080pa	15160pa
		15240pa	15415pa 17750as 17795pa
		19000pa	
0200 0300	Bahrain, R Bahrain	6010me	
0200 0300	Canada, CFRX Toronto ON	6070na	
0200 0300	Canada, CFVP Calgary AB	6030na	
0200 0300	Canada, CKZN St Johns NF	6160na	
0200 0300	Canada, CKZU Vancouver BC	6160na	
0200 0300	China, China R International	11770as	
		13640as	
0200 0300	Cuba, R Havana Cuba	6000na	6050na
0200 0300	Egypt, R Cairo	9720na	
0200 0300	Malaysia, RTM Kajang/Traxx FM	7295do	
0200 0300	Micronesia, V6MP/Cross R/Pohnpei	4755as	
0200 0300	New Zealand, R New Zealand Intl	15720pa	
0200 0300 DRM	New Zealand, R New Zealand Intl	17675pa	
0200 0300	Palau, T8WH/World Harvest R	17800as	
0200 0300	Philippines, R Pilipinas Overseas	11880me	
		15285me	17700me
0200 0300	Russia, VO Russia	9665va	15425na

0200 0300	South Korea, KBS World R	9580sa	
0200 0300 mtwhfa	Sri Lanka, SLBC 6005as	9770as	15745as
0200 0300	Taiwan, R Taiwan Intl	5950na	9680na
0200 0300	UK, BBC World Service	6005af	6195me
	12095as	15310as	17790as
0200 0300	USA, Amer Forces Network/AFRTS	4319usb	
	5446usb	5765usb	7811usb
	12759usb	13362usb	
0200 0300	USA, FBN/WTJC Newport NC	9370na	
0200 0300 Sat/Sun	USA, WBCQ Monticello ME5110am		
0200 0300	USA, WBCQ Monticello ME7490am	9330am	
0200 0300	USA, WEWN/EWTN Irondale AL	11520af	
0200 0300	USA, WHRI Cypress Creek SC	5920va	
0200 0300	USA, WINB Red Lion PA	9265am	
0200 0300 irreg	USA, WRNO New Orleans LA	7505am	
0200 0300	USA, WTWV Lebanon TN	5755va	
0200 0300	USA, WWCN Nashville TN	3215eu	4840na
	5890af	5935af	
0200 0300	USA, WWRB Manchester TN	3185na	
	5050na		
0200 0300	USA, WYFR/Family R Worldwide	5985ca	
	6145na		
0200 0300	Zambia, Christian Voice	4965as	
0215 0227	Nepal, R Nepal	5005do	
0230 0300	Myanmar, Myanma R/Yangon	9731do	
0230 0300	Vietnam, VO Vietnam/Overseas Svc	6175na	
0245 0300	Australia, HCJB Global Australia	15400as	
0245 0300	India, AIR/Bhopal	4810do	
0245 0300	India, AIR/Guwahati	4940do	
0245 0300	India, AIR/Hyderabad	7420do	
0245 0300	India, AIR/Imphal	4775do	7335do
0245 0300	India, AIR/Itanagar	4990do	
0245 0300	India, AIR/Jaipur	4910do	7325do
0245 0300	India, AIR/Jepore	5040do	
0245 0300	India, AIR/Kolkata	4820do	7210do
0245 0300	India, AIR/Kuresong	4895do	
0245 0300	India, AIR/Lucknow	4880do	7440do
0245 0300	India, AIR/Shillong	4970do	
0245 0300	India, AIR/Shimla	4965do	6020do
0245 0300	India, AIR/Thiruvananthapuram	5010do	
0250 0300	Vatican City State, Vatican R7305am		
0255 0300 Sun	Swaziland, TVR Africa	3200af	

0300 UTC - 11PM EDT / 10PM CDT / 8PM PDT

0300 0315	India, AIR/Aizawl	5050do	7295do
0300 0315	India, AIR/Imphal	4775do	7335do
0300 0315	India, AIR/Itanagar	4990do	
0300 0315	India, AIR/Shillong	4970do	
0300 0320	Vatican City State, Vatican R7305am		
0300 0325 Sun	Swaziland, TVR Africa	3200af	
0300 0330	Egypt, R Cairo	9720na	
0300 0330	Myanmar, Myanma R/Yangon	9731do	
0300 0330	Philippines, R Pilipinas Overseas	11880me	
	15285me	17700me	
0300 0330	Vatican City State, Vatican R7360af	15460as	
0300 0355	South Africa, Channel Africa	5980af	
0300 0355	Turkey, Voice of Turkey	6165as	9515va
0300 0356	Romania, R Romania Intl	9645na	11795na
	11895as	15340as	
0300 0400	Anguilla, University Network	6090na	
0300 0400	Australia, ABC NT Alice Springs	4835do	
0300 0400	Australia, ABC NT Katherine	5025do	
0300 0400	Australia, ABC NT Tennant Creek	4910do	
0300 0400	Australia, ABC/R Australia	15160pa	15240pa
	15415pa	17750as	21725pa
0300 0400	Bahrain, R Bahrain	6010me	
0300 0400	Canada, CFRX Toronto ON	6070na	
0300 0400	Canada, CFVP Calgary AB	6030na	
0300 0400	Canada, CKZN St Johns NF6160na		
0300 0400	Canada, CKZU Vancouver BC	6160na	
0300 0400	China, China R International	9690am	
	9790na	11770as	13750as
	15120as	15785as	15110as
0300 0400	Cuba, R Havana Cuba	6000na	6050na
0300 0400	Malaysia, RTM Kajang/Traxx FM	7295do	
0300 0400	Micronesia, V6MP/Cross R/Pohnpei	4755as	
0300 0400	New Zealand, R New Zealand Intl	15720pa	

0300 0400 DRM	New Zealand, R New Zealand Intl	17675pa	
0300 0400	Oman, R Sultanate of Oman	15355af	
0300 0400	Palau, T8WH/World Harvest R	17800af	
0300 0400	Russia, VO Russia	9665va	15425na
0300 0400	South Africa, Channel Africa	3345af	
0300 0400 Sun	Sri Lanka, SLBC 6005as	9770as	15745as
0300 0400	Taiwan, R Taiwan Intl	5950na	15320as
0300 0400	UK, BBC World Service	3255af	5875af
	6005af	6145af	6190af
	9410me	9750af	12035af
	15310as	15365as	17790as
0300 0400	USA, Amer Forces Network/AFRTS	4319usb	
	5446usb	5765usb	7811usb
	12759usb	13362usb	
0300 0400	USA, BBG/Voice of America	4930af	
	6080af	9855af	15580af
0300 0400	USA, FBN/WTJC Newport NC	9370na	
0300 0400	USA, WBCQ Monticello ME7490am	9330am	
0300 0400	USA, WEWN/EWTN Irondale AL	11520af	
0300 0400	USA, WHRI Cypress Creek SC	5920va	
	7385na	9825va	
0300 0400 irreg	USA, WRNO New Orleans LA	7505am	
0300 0400	USA, WTWV Lebanon TN	5755va	
0300 0400	USA, WWCN Nashville TN	3215eu	4840na
	5890af	5935af	
0300 0400	USA, WWRB Manchester TN	3185na	
	5050na		
0300 0400	USA, WYFR/Family R Worldwide	11740ca	
0300 0400	Zambia, Christian Voice	4965as	
0330 0400	Australia, ABC/R Australia	15515pa	
0330 0400	Iran, VO Islamic Rep of Iran	11920eu	13650eu
0330 0400	Vietnam, VO Vietnam/Overseas Svc	6175na	
0335 0345	India, AIR/Kolkata	4820do	7210do

0400 UTC - 12AM EDT / 11PM CDT / 9PM PDT

0400 0430	Iran, VO Islamic Rep of Iran	11920eu	13650eu
0400 0430	USA, BBG/Voice of America	9855af	
0400 0457	Germany, Deutsche Welle	6180af	7240af
	9470af	12045af	
0400 0457	North Korea, VO Korea	3560as	7220as
	9345as	9730as	11735as
	15180as		13760as
0400 0458	New Zealand, R New Zealand Intl	15720pa	
0400 0458 DRM	New Zealand, R New Zealand Intl	17675pa	
0400 0500	Anguilla, University Network	6090na	
0400 0500	Australia, ABC NT Alice Springs	4835do	
0400 0500	Australia, ABC NT Katherine	5025do	
0400 0500	Australia, ABC NT Tennant Creek	4910do	
0400 0500	Australia, ABC/R Australia	15160pa	15240pa
	15415pa	15515pa	21725as
0400 0500	Bahrain, R Bahrain	6010me	
0400 0500	Canada, CFRX Toronto ON	6070na	
0400 0500	Canada, CKZN St Johns NF6160na		
0400 0500	Canada, CKZU Vancouver BC	6160na	
0400 0500	China, China R International	6080na	
	17730va	17855va	
0400 0500	Cuba, R Havana Cuba	6000na	6050na
0400 0500	Malaysia, RTM Kajang/Traxx FM	7295do	
0400 0500	Micronesia, V6MP/Cross R/Pohnpei	4755as	
0400 0500	Russia, VO Russia	13775na	15760me
0400 0500	South Africa, Channel Africa	3345af	
0400 0500 Sun	Sri Lanka, SLBC 6005as	9770as	15745as
0400 0500 DRM	UK, BBC World Service	3955eu	
0400 0500	UK, BBC World Service	3255af	5875af
	6005af	6190af	7310af
	12035af	12095me	15310as
	17790as		15365as
0400 0500	USA, Amer Forces Network/AFRTS	4319usb	
	5446usb	5765usb	7811usb
	12759usb	13362usb	
0400 0500	USA, BBG/Voice of America	4930af	
	4960af	6080af	12025af
0400 0500	USA, FBN/WTJC Newport NC	9370na	
0400 0500	USA, Overcomer Ministry	15750af	
0400 0500	USA, WBCQ Monticello ME9330am		
0400 0500	USA, WEWN/EWTN Irondale AL	11520af	
0400 0500	USA, WHRI Cypress Creek SC	5920va	
	7385na	9825va	

0400 0500	USA, WTTW Lebanon TN	5755va	
0400 0500	USA, WWCR Nashville TN	3215eu	4840na
	5890af	5935af	
0400 0500	USA, WWRB Manchester TN		3185na
0400 0500	Zambia, Christian Voice	4965as	
0430 0500	Myanmar, Thazin BC Sta	6030do	
0430 0500 mtwhf	Swaziland, TWR Africa	3200af	
0455 0500	Nigeria, VO Nigeria	15120af	
0459 0500	New Zealand, R New Zealand Intl		11725pa
0459 0500 DRM	New Zealand, R New Zealand Intl		11675pa

0500 UTC - 1AM EDT / 12AM CDT / 10PM PDT

0500 0527	Germany, Deutsche Welle	5925af	
0500 0530	Japan, R Japan NHK World		5975eu
	6110na	11970va	
0500 0530	Vatican City State, Vatican R	11625af	13765af
0500 0557	North Korea, VO Korea	13650as	15100as
0500 0600	Anguilla, University Network		6090na
0500 0600	Australia, ABC NT Alice Springs		4835do
0500 0600	Australia, ABC NT Katherine		5025do
0500 0600	Australia, ABC NT Tennant Creek		4910do
0500 0600	Australia, ABC/R Australia	13630pa	15240pa
	15415pa	15515pa	21725as
0500 0600	Bahrain, R Bahrain		6010me
0500 0600	Bhutan, Bhutan BC Svc	5030do	6035do
0500 0600	Canada, CFRX Toronto ON	6070na	
0500 0600	Canada, CKZN St Johns NF	6160na	
0500 0600	Canada, CKZU Vancouver BC		6160na
0500 0600	China, China R International		11710af
	11895as	15350as	15465as
	17730va	17855va	17505va
0500 0600	Cuba, R Havana Cuba	6010na	6050na
	6060ca	6125am	
0500 0600	Eqt Guinea, Pan American BC/R Africa		15190af
0500 0600	Germany, Deutsche Welle	9470af	9800af
	9850af	11800af	
0500 0600	Malaysia, RTM Kajang/Traxx FM		7295do
0500 0600	Micronesia, V6MP/Cross R/Pohnpei		4755as
0500 0600	Myanmar, Thazin BC Sta	6030do	
0500 0600	New Zealand, R New Zealand Intl		11725pa
0500 0600 DRM	New Zealand, R New Zealand Intl		11675pa
0500 0600	Nigeria, VO Nigeria	15120	ad
0500 0600	Russia, VO Russia	13755na	
0500 0600	South Africa, Channel Africa		7230af
0500 0600 Sat/Sun	Swaziland, TWR Africa	3200af	
0500 0600	Swaziland, TWR Africa	9500af	
0500 0600	Taiwan, R Taiwan Intl	5950na	
0500 0600	UK, BBC World Service	3255af	5875af
	6005af	6190af	9410af
	12095me	15310as	15365as
	17640as	17790as	15420af
0500 0600 DRM	UK, BBC World Service	3955eu	
0500 0600	USA, Amer Forces Network/AFRTS		4319usb
	5446usb	5765usb	7811usb
	12759usb	13362usb	12133usb
0500 0600	USA, BBG/Voice of America		4930af
	6080af	12025af	15580af
0500 0600	USA, FBN/WTJC Newport NC		9370na
0500 0600	USA, Overcomer Ministry	15750af	
0500 0600	USA, WBCQ Monticello ME	9330am	
0500 0600	USA, WEWN/EWTN Irontdale AL		11520af
0500 0600	USA, WHRI Cypress Creek SC		5920am
	7385na	9825va	
0500 0600	USA, WTTW Lebanon TN	5755va	
0500 0600	USA, WWCR Nashville TN	3215eu	4840na
	5890af	5935af	
0500 0600	USA, WWRB Manchester TN		3185na
0500 0600	Zambia, Christian Voice	6065af	
0530 0556 DRM	Romania, R Romania Intl	11875eu	
0530 0556	Romania, R Romania Intl	9700eu	17760eu
	21500eu		
0530 0600	Australia, ABC/R Australia	17750as	
0530 0600	Thailand, R Thailand World Svc		17770eu

0600 UTC - 2AM EDT / 1AM CDT / 11PM PDT

0600 0627	Germany, Deutsche Welle	15275af	
-----------	-------------------------	---------	--

0600 0630	China, Xizang PBS	6025do	6130do
	9580do		
0600 0630	Germany, Deutsche Welle	13780af	17820af
0600 0630	Myanmar, Thazin BC Sta	6030do	
0600 0630 Sat/Sun	USA, WRMI/R Prague relay	9955ca	
0600 0645 mtwhfa	Vatican City State, Vatican R	15595me	
0600 0650	New Zealand, R New Zealand Intl		11725pa
0600 0650 DRM	New Zealand, R New Zealand Intl		11675pa
0600 0655	South Africa, Channel Africa		15255af
0600 0657	North Korea, VO Korea	7220as	9345as
	9730as		
0600 0700	Anguilla, University Network		6090na
0600 0700	Australia, ABC NT Alice Springs		4835do
0600 0700	Australia, ABC NT Katherine		5025do
0600 0700	Australia, ABC NT Tennant Creek		4910do
0600 0700	Australia, ABC/R Australia	11945pa	13630pa
	15240pa	15415pa	17750as
0600 0700	Bahrain, R Bahrain		6010me
0600 0700	Canada, CFRX Toronto ON	6070na	
0600 0700	Canada, CFVP Calgary AB	6030na	
0600 0700	Canada, CKZN St Johns NF	6160na	
0600 0700	Canada, CKZU Vancouver BC		6160na
0600 0700	China, China R International		11710af
	11870me	11895as	13660as
	15350as	15465as	17505va
	17710as		
0600 0700	Cuba, R Havana Cuba	6010na	6050na
	6060ca	6125am	
0600 0700	Eqt Guinea, Pan American BC/R Africa		15190af
0600 0700	Malaysia, RTM Kajang/Traxx FM		7295do
0600 0700	Micronesia, V6MP/Cross R/Pohnpei		4755as
0600 0700	Nigeria, VO Nigeria	15120af	
0600 0700	Papua New Guinea, R Fly	3915do	
0600 0700	Russia, VO Russia	21800pa	21810va
0600 0700 DRM	Russia, VO Russia		11830eu
0600 0700	South Africa, Channel Africa		7230af
0600 0700	Swaziland, TWR Africa	6120af	9500af
0600 0700 Sat/Sun	Swaziland, TWR Africa	3200af	
0600 0700	UK, BBC World Service	6005af	6190af
	9410af	12095va	15105af
	17640af	17790as	15310as
0600 0700 DRM	UK, BBC World Service	5875eu	7355eu
0600 0700 mtwhf	UK, BBC World Service	15420af	
0600 0700	USA, Amer Forces Network/AFRTS		4319usb
	5446usb	5765usb	7811usb
	12759usb	13362usb	12133usb
0600 0700	USA, BBG/Voice of America		6080af
	12025af	15580af	
0600 0700	USA, FBN/WTJC Newport NC		9370na
0600 0700	USA, Overcomer Ministry	15750af	
0600 0700	USA, WBCQ Monticello ME	9330am	
0600 0700	USA, WEWN/EWTN Irontdale AL		11520af
0600 0700	USA, WHRI Cypress Creek SC		5920am
	7385na	11910va	
0600 0700	USA, WTTW Lebanon TN	5755va	
0600 0700	USA, WWCR Nashville TN	3215eu	4840na
	5890af	5935af	
0600 0700	USA, WWRB Manchester TN		3185na
0600 0700	Zambia, Christian Voice	6065af	
0600 0700	Zambia, CVC Intl/1 Africa	13590af	
0617 0630 Sun	Nepal, R Nepal	5005do	
0630 0645	India, AIR/Guwahati	4940do	7280do
0630 0645	India, AIR/Hyderabad	7420do	
0630 0645	India, AIR/Mumbai	4840do	7240do
0630 0645	India, AIR/Thiruvananthapuram		5010do
0630 0700	Germany, Deutsche Welle	13780af	17820af
0630 0700	Vatican City State, Vatican R	11625af	13765af
	15570af		
0645 0700 mtwhf	Israel, Kol Israel	9955na	
0651 0700	New Zealand, R New Zealand Intl		11725pa
0651 0700 DRM	New Zealand, R New Zealand Intl		9890pa

0700 UTC - 3AM EDT / 2AM CDT / 12AM PDT

0700 0730	Myanmar, Myanma R/Yangon		9731do
0700 0750	Austria, TWR Europe	6105eu	
0700 0750	Germany, TWR Europe	6105eu	
0700 0758	New Zealand, R New Zealand Intl		11725pa

0700 0758 DRM	New Zealand, R New Zealand Intl	9890pa
0700 0800	Anguilla, University Network	6090na
0700 0800	Australia, ABC NT Alice Springs	4835do
0700 0800	Australia, ABC NT Katherine	5025do
0700 0800	Australia, ABC NT Tennant Creek	4910do
0700 0800	Australia, ABC/R Australia	7410pa 9475pa
	9710pa 11945pa 13630pa	15240pa
0700 0800	Bahrain, R Bahrain	6010me
0700 0800 m/DRM	Belgium, TDP Radio	6015eu
0700 0800	Canada, CFRX Toronto ON	6070na
0700 0800	Canada, CFVP Calgary AB	6030na
0700 0800	Canada, CKZN St Johns NF	6160na
0700 0800	Canada, CKZU Vancouver BC	6160na
0700 0800	China, China R International	11895as
	13660as 13710eu 15125va	15350as
	15465as 17490eu 17540as	17710as
0700 0800 mtwhfa	Ecuador, HCJB/LV de los Andes	3995eu
0700 0800	Eqt Guinea, Pan American BC/R Africa	15190af
0700 0800	Malaysia, RTM Kajang/Traxx FM	7295do
0700 0800	Micronesia, V6MP/Cross R/Pohnpei	4755as
0700 0800	Papua New Guinea, R Fly	3915do
0700 0800	Russia, VO Russia	21800pa 21810va
0700 0800 DRM	Russia, VO Russia	11830eu
0700 0800	South Africa, Channel Africa	9625af
0700 0800	Swaziland, TWR Africa	6120af 9500af
0700 0800 Sat/Sun	Swaziland, TWR Africa	3200af
0700 0800	UK, BBC World Service	6190af 11760me
	11770af 12095af 15310af	15400af
	15575me 17640af 17790as	17830af
0700 0800 DRM	UK, BBC World Service	5875eu 7355eu
0700 0800	USA, Amer Forces Network/AFRTS	4319usb
	5446usb 5765usb 7811usb	12133usb
	12759usb 13362usb	
0700 0800	USA, FBN/WTJC Newport NC	9370na
0700 0800	USA, WBCQ Monticello ME	9330am
0700 0800	USA, WEWN/EWTN Irontdale AL	11520af
0700 0800	USA, WHRI Cypress Creek SC	5920am
	7385na	
0700 0800	USA, WTWW Lebanon TN	5755va
0700 0800	USA, WWCR Nashville TN	3215eu 4840na
	5890af 5935af	
0700 0800	USA, WWRB Manchester TN	3185na
0700 0800	Zambia, Christian Voice	6065af
0700 0800	Zambia, CVC Intl/1 Africa	13590af
0730 0745	India, AIR/Aizawl	5050do 7295do
0730 0745	India, AIR/Chennai	4920do 7380do
0730 0745	India, AIR/Guwahati	4940do 7280do
0730 0745	India, AIR/Imphal	4775do 7335do
0730 0745	India, AIR/Jaipur	4910do 7325do
0730 0745	India, AIR/Kolkata	4820do 7210do
0730 0745	India, AIR/Shimla	4965do 6020do
0730 0800	Australia, HCJB Global Australia	11750as
0759 0800	New Zealand, R New Zealand Intl	6170pa
0759 0800 DRM	New Zealand, R New Zealand Intl	7440pa

0800 UTC - 4AM EDT / 3AM CDT / 1AM PDT

0800 0830	Australia, ABC NT Alice Springs	4835do
0800 0830	Australia, ABC NT Katherine	5025do
0800 0830	Australia, ABC NT Tennant Creek	4910do
0800 0830	Australia, HCJB Global Australia	11750as
0800 0830 Sun	Canada, Bible Voice Broadcasting	5945eu
0800 0830	France, R France International	9955na
0800 0845 Sat	Canada, Bible Voice Broadcasting	5945eu
0800 0900	Anguilla, University Network	6090na
0800 0900	Australia, ABC/R Australia	5995pa 7410pa
	9475pa 9580pa 9710pa	11945pa
	15240pa	
0800 0900	Bahrain, R Bahrain	6010me
0800 0900 t/DRM	Belgium, TDP Radio	6015eu
0800 0900	Canada, CFRX Toronto ON	6070na
0800 0900	Canada, CFVP Calgary AB	6030na
0800 0900	Canada, CKZN St Johns NF	6160na
0800 0900	Canada, CKZU Vancouver BC	6160na
0800 0900	China, China R International	11620as
	11895as 13710eu 15350as	15465as
	15625va 17490eu 17540as	

0800 0900	Eqt Guinea, Pan American BC/R Africa	15190af
0800 0900 Sat	Italy, IRRS SW	9510va
0800 0900	Malaysia, RTM Kajang/Traxx FM	7295do
0800 0900	Micronesia, V6MP/Cross R/Pohnpei	4755as
0800 0900	New Zealand, R New Zealand Intl	6170pa
0800 0900 DRM	New Zealand, R New Zealand Intl	7440pa
0800 0900 mtwhfs	Palau, T8WH/World Harvest R	9930as
0800 0900	Palau, T8WH/World Harvest R	17650as
0800 0900	Papua New Guinea, R Fly	3915do
0800 0900	Russia, VO Russia	21800pa 21810va
0800 0900 DRM	Russia, VO Russia	9850eu 11830eu
0800 0900	South Africa, Channel Africa	9625af
0800 0900 Sun	South Africa, R Mirror Intl	7205af 17570af
0800 0900	South Korea, KBS World R	9570as
0800 0900	UK, BBC World Service	6190af 11760me
	12095af 15310as 15400af	15575me
	17640af 17790as 17830af	21470af
0800 0900	USA, Amer Forces Network/AFRTS	4319usb
	5446usb 5765usb 7811usb	12133usb
	12759usb 13362usb	
0800 0900	USA, FBN/WTJC Newport NC	9370na
0800 0900	USA, WBCQ Monticello ME	9330am
0800 0900	USA, WEWN/EWTN Irontdale AL	11520af
0800 0900	USA, WHRI Cypress Creek SC	5920am
	7385na	
0800 0900	USA, WTWW Lebanon TN	5755va
0800 0900	USA, WWCR Nashville TN	3215eu 4840na
	5890af 5935af	
0800 0900	USA, WWRB Manchester TN	3185na
0800 0900	Zambia, Christian Voice	6065af
0800 0900	Zambia, CVC Intl/1 Africa	13590af
0815 0827	Nepal, R Nepal	5005do
0820 0900 mtwhfa	Guam, KTWR/TWR Asia	15170as
0830 0845	India, AIR/Aizawl	5050do 7295do
0830 0845	India, AIR/Chennai	4920do 7380do
0830 0845	India, AIR/Hyderabad	7420do
0830 0845	India, AIR/Imphal	4775do 7335do
0830 0845	India, AIR/Kolkata	4820do 7210do
0830 0845	India, AIR/Shillong	4970do 7315do
0830 0845	India, AIR/Thiruvananthapuram	5010do
0830 0900	Australia, ABC NT Alice Springs	2310do
0830 0900	Australia, ABC NT Katherine	2485do
0830 0900	Australia, ABC NT Tennant Creek	2325do
0830 0900 mtwhfa	Guam, KTWR/TWR Asia	11840pa
0830 0900	India, AIR/Itanagar	4990do

0900 UTC - 5AM EDT / 4AM CDT / 2AM PDT

0900 0910 mtwhfa	Guam, KTWR/TWR Asia	11840as
0900 0930 mtwhfa	USA, WRMI/R Prague relay	9955ca
0900 1000	Anguilla, University Network	6090na
0900 1000	Australia, ABC NT Alice Springs	2310do
0900 1000	Australia, ABC NT Katherine	2485do
0900 1000	Australia, ABC NT Tennant Creek	2325do
0900 1000	Australia, ABC/R Australia	6020pa 9580pa
	11945pa	
0900 1000	Bahrain, R Bahrain	6010me
0900 1000 w/DRM	Belgium, TDP Radio	6015eu
0900 1000	Canada, CFRX Toronto ON	6070na
0900 1000	Canada, CFVP Calgary AB	6030na
0900 1000	Canada, CKZN St Johns NF	6160na
0900 1000	Canada, CKZU Vancouver BC	6160na
0900 1000	China, China R International	11620as
	13790pa 15210as 15270eu	15350as
	17490eu 17570eu 17750as	
0900 1000 Sat/Sun	Germany, Mighty KBC Radio	6095eu
0900 1000	Malaysia, RTM Kajang/Traxx FM	7295do
0900 1000	Micronesia, V6MP/Cross R/Pohnpei	4755as
0900 1000 3rd Sun	Netherlands, XVRB Radio	6045eu
0900 1000 DRM	New Zealand, R New Zealand Intl	7440pa
0900 1000	New Zealand, R New Zealand Intl	6170pa
0900 1000	Nigeria, VO Nigeria	9690af
0900 1000	Palau, T8WH/World Harvest R	9930as
0900 1000	Papua New Guinea, R Fly	3915do
0900 1000	Russia, VO Russia	9560as 15170as
	21800pa 21810va	
0900 1000 DRM	Russia, VO Russia	9850eu 11830eu

0900 1000	South Africa, Channel Africa	9625af
0900 1000	UK, BBC World Service	6190af 6195as
	9740as 11760me 12095af	15285as
	15310as 15575me 17640af	17760as
	17790as 17830af 21470af	21660as
0900 1000	USA, Amer Forces Network/AFRTS	4319usb
	5446usb 5765usb 7811usb	12133usb
	12759usb 13362usb	
0900 1000	USA, FBN/WTJC Newport NC	9370na
0900 1000	USA, WBCQ Monticello ME9330am	
0900 1000	USA, WEWN/EWTN Irondale AL	11520as
0900 1000	USA, WHRI Cypress Creek SC	11565pa
0900 1000	USA, WHRI Cypress Creek SC	7315am
	7385na	
0900 1000	USA, WTWV Lebanon TN	5755va
0900 1000	USA, WWCR Nashville TN	4840eu 5890af
	5935af 6875af	
0900 1000	USA, WWRB Manchester TN	3185na
0900 1000	USA, WYFR/Family R Worldwide	9465as
0900 1000	Zambia, Christian Voice	6065af
0900 1000	Zambia, CVC Intl/1 Africa	13590af
0905 0910	Pakistan, PBC/R Pakistan	15725as 17720as
0930 1000 fs	China, VO the Strait	6115do
0930 1000 Sun	Italy, IRRS SW	9510va

1000 UTC - 6AM EDT / 5AM CDT / 3AM PDT

1000 1030	Japan, R Japan NHK World	9605as
	9625pa 9695as	
1000 1030	Vietnam, VO Vietnam/Overseas Svc	9840as
	12020as	
1000 1057	North Korea, VO Korea	3560ca 11710sa
	15180as 11735as 13650as	
1000 1058	New Zealand, R New Zealand Intl	6170pa
1000 1100	Anguilla, University Network	11775na
1000 1100	Australia, ABC NT Alice Springs	2310do
1000 1100	Australia, ABC NT Katherine	2485do
1000 1100	Australia, ABC NT Tennant Creek	2325do
1000 1100	Australia, ABC/R Australia	6020pa 9580pa
	11945pa	
1000 1100	Bahrain, R Bahrain	6010me
1000 1100 h/DRM	Belgium, TDP Radio	6015eu
1000 1100	Canada, CFRX Toronto ON	6070na
1000 1100	Canada, CFVP Calgary AB	6030na
1000 1100	Canada, CKZN St Johns NF	6160na
1000 1100	Canada, CKZU Vancouver BC	6160na
1000 1100	China, China R International	6040na
	11610as 11635as 13620as	13690as
	13720as 13790pa 15190as	15210as
	15350as 17490eu	
1000 1100 Sat/Sun	Germany, Mighty KBC Radio	6095eu
1000 1100	India, AIR/External Svc	7270as 13695pa
	15020as 15410as 17510pa	17800as
	17895pa	
1000 1100	Indonesia, VO Indonesia	9526va
1000 1100	Malaysia, RTM Kajang/Traxx FM	7295do
1000 1100	Micronesia, V6MP/Cross R/Pohnpei	4755as
1000 1100 DRM	New Zealand, R New Zealand Intl	7440pa
1000 1100	Nigeria, VO Nigeria	9690af
1000 1100	Palau, T8WH/World Harvest R	17650as
1000 1100	Russia, VO Russia	9560as 11500as
	15170as	
1000 1100	Saudi Arabia, BSKSA/External Svc	15250as
1000 1100	South Africa, Channel Africa	9625af
1000 1100	UK, BBC World Service	6190af 6195as
	9740as 11760me 12095af	15285as
	15310as 15575me 17640af	17760as
	17790as 21470af 21660as	
1000 1100 Sat/Sun	UK, BBC World Service	15400af 17830af
1000 1100	USA, Amer Forces Network/AFRTS	4319usb
	5446usb 5765usb 7811usb	12133usb
	12759usb 13362usb	
1000 1100	USA, FBN/WTJC Newport NC	9370na
1000 1100	USA, KNLS Anchor Point AK	9655as
1000 1100	USA, WBCQ Monticello ME9330am	
1000 1100	USA, WEWN/EWTN Irondale AL	11520as

1000 1100	USA, WHRI Cypress Creek SC	7315am
	7385na	
1000 1100	USA, WTWV Lebanon TN	5755va
1000 1100	USA, WWCR Nashville TN	4840na 5890af
	5935af 6875af	
1000 1100	USA, WWRB Manchester TN	3185na
1000 1100	USA, WYFR/Family R Worldwide	9465as
1000 1100	Zambia, Christian Voice	6065af
1000 1100	Zambia, CVC Intl/1 Africa	13590af
1030 1100	Iran, VO Islamic Rep of Iran	21590va 21640va
1030 1100	Mongolia, Voice of Mongolia	12085as
1030 1100	USA, WINB Red Lion PA	9265am
1059 1100	New Zealand, R New Zealand Intl	9655pa

1100 UTC - 7AM EDT / 6AM CDT / 4AM PDT

1100 1104	Pakistan, PBC/R Pakistan	15725as 17720as
1100 1127	Iran, VO Islamic Rep of Iran	21590va 21640va
1100 1130 Sat/DRM	South Korea, KBS World R	9760eu
1100 1130	UK, BBC World Service	15400af
1100 1130	Vietnam, VO Vietnam/Overseas Svc	7285as
1100 1156	Romania, R Romania Intl	15210eu 15430eu
	17510af 17670af	
1100 1158 DRM	New Zealand, R New Zealand Intl	7440pa
1100 1200	Anguilla, University Network	11775na
1100 1200	Australia, ABC NT Alice Springs	2310do
1100 1200	Australia, ABC NT Katherine	2485do
1100 1200	Australia, ABC NT Tennant Creek	2325do
1100 1200	Australia, ABC/R Australia	6020pa 6080pa
	6140as 9475as 9580pa	11945va
1100 1200 DRM	Australia, ABC/R Australia	12080pa
1100 1200	Bahrain, R Bahrain	6010me
1100 1200 f/DRM	Belgium, TDP Radio	6015eu
1100 1200	Canada, CFRX Toronto ON	6070na
1100 1200	Canada, CFVP Calgary AB	6030na
1100 1200	Canada, CKZN St Johns NF	6160na
1100 1200	Canada, CKZU Vancouver BC	6160na
1100 1200	China, China R International	5955as
	11650as 11660as 11750na	11795as
	13590as 13645as 13650eu	13720as
	16490eu	
1100 1200 Sat/Sun	Germany, Mighty KBC Radio	6095eu
1100 1200	Malaysia, RTM Kajang/Traxx FM	7295do
1100 1200	New Zealand, R New Zealand Intl	9655pa
1100 1200	Nigeria, VO Nigeria	9690af
1100 1200 DRM	Russia, VO Russia	12030as
1100 1200	Russia, VO Russia	9560as 11500as
	12065as	
1100 1200	Saudi Arabia, BSKSA/External Svc	15250as
1100 1200	South Africa, Channel Africa	9625af
1100 1200	Taiwan, R Taiwan Intl	7445as 9465as
1100 1200	UK, BBC World Service	6190af 6195as
	9740as 11760me 12095af	15285as
	15310as 15575me 17640af	17790as
	17830af 21470af	
1100 1200	USA, Amer Forces Network/AFRTS	4319usb
	5446usb 5765usb 7811usb	12133usb
	12759usb 13362usb	
1100 1200	USA, FBN/WTJC Newport NC	9370na
1100 1200	USA, WBCQ Monticello ME9330am	
1100 1200	USA, WEWN/EWTN Irondale AL	11520as
1100 1200	USA, WHRI Cypress Creek SC	7315am
	9795am	
1100 1200	USA, WINB Red Lion PA	9265am
1100 1200	USA, WTWV Lebanon TN	5755va
1100 1200	USA, WWCR Nashville TN	4840na 5890af
	5935af 15825eu	
1100 1200	USA, WWRB Manchester TN	3185na
1100 1200	Zambia, Christian Voice	6065af
1100 1200	Zambia, CVC Intl/1 Africa	13590af
1130 1145 f	Palau, T8WH/World Harvest R	15525as
1130 1200 f	Vatican City State, Vatican R	15595me 17590me
1130 1200	Vietnam, VO Vietnam/Overseas Svc	9840as
	12020as	
1135 1145	India, AIR/Aizawl	5050do 7295do
1135 1145	India, AIR/Shillong	4970do

1200 UTC - 8AM EDT / 7AM CDT / 5AM PDT

1200 1225	Saudi Arabia, BSKSA/External Svc	15250as
1200 1230	Germany, AWR Europe	17535as
1200 1230	Indonesia, AWR Asia/Pacific	17535as
1200 1230	Japan, R Japan NHK World	6120na
	9695as	
1200 1259	New Zealand, R New Zealand Intl	9655pa
1200 1300	Anguilla, University Network	11775na
1200 1300	Australia, ABC NT Alice Springs	2310do
1200 1300	Australia, ABC NT Katherine	2485do
1200 1300	Australia, ABC NT Tennant Creek	2325do
1200 1300	Australia, ABC/R Australia	5995pa 6020pa
	6080pa 6140as 9475as	9580pa
	11945as	12080pa
1200 1300	Bahrain, R Bahrain	6010me
1200 1300 Sat/DRM	Belgium, TDP Radio	6015eu
1200 1300	Canada, CFRX Toronto ON	6070na
1200 1300	Canada, CFVP Calgary AB	6030na
1200 1300	Canada, CKZN St Johns NF	6160na
1200 1300	Canada, CKZU Vancouver BC	6160na
1200 1300	China, China R International	5955as
	9460as 9645as 9660as	9730as
	9760pa 11650as 11660as	11690va
	11760pa 11980as 13645as	13650eu
	13790eu 17490eu	
1200 1300	Ethiopia, R Ethiopia/Natl Pgm	9705do
1200 1300 Sat/Sun	Germany, Mighty KBC Radio	6095eu
1200 1300	Malaysia, RTM Kajang/Traxx FM	7295do
1200 1300	Nigeria, VO Nigeria	9690af
1200 1300	Palau, T8WH/World Harvest R	9930as
1200 1300 DRM	Russia, VO Russia	9445eu 9850as
	12030as	
1200 1300	Russia, VO Russia	9560as 11500as
1200 1300	South Korea, KBS World R	9650na
1200 1300	UK, BBC World Service	5875as 6190af
	6195as 9740as 11750as	11760me
	15310as 15575me 17790as	17830af
	21470af	
1200 1300	USA, Amer Forces Network/AFRTS	4319usb
	5446usb 5765usb 7811usb	12133usb
	12759usb 13362usb	
1200 1300	USA, BBG/Voice of America	7575as
	9510as 12075as 12150as	
1200 1300	USA, FBN/WTJC Newport NC	9370na
1200 1300	USA, KNLS Anchor Point AK	7355as
1200 1300	USA, WBCQ Monticello ME	9330am
1200 1300	USA, WEWN/EWTN Irondale AL	11520as
1200 1300	USA, WHRI Cypress Creek SC	9795am
	9840na	
1200 1300	USA, WINB Red Lion PA	9265am
1200 1300	USA, WTWW Lebanon TN	5755va
1200 1300	USA, WWCR Nashville TN	7490na 9980af
	13845af 15825eu	
1200 1300	USA, WWRB Manchester TN	9385na
1200 1300	Zambia, Christian Voice	6065af
1200 1300	Zambia, CVC Intl/1 Africa	13590af
1215 1300	Egypt, R Cairo	17870as
1225 1245	India, AIR/Imphal	4775do
1230 1245	India, AIR/Aizawl	5050do 7295do
1230 1245	India, AIR/Chennai	4920do
1230 1245	India, AIR/Hyderabad	4800do
1230 1245	India, AIR/Imphal	4800do
1230 1245	India, AIR/Jeyapore	5040do
1230 1245	India, AIR/Kuresong	4895do
1230 1245	India, AIR/Port Blair/Andaman & Nicobar	4760do
1230 1245	India, AIR/R Kashmir	4950do
1230 1245	India, AIR/Shillong	4970do
1230 1245	India, AIR/Thiruvananthapuram	5010do
1230 1300	Australia, HCJB Global Australia	15400as
1230 1300	Thailand, R Thailand World Svc	9890va
1230 1300	Turkey, Voice of Turkey	15450va
1230 1300	Vietnam, VO Vietnam/Overseas Svc	9840as
	12020as	

1300 UTC - 9AM EDT / 8AM CDT / 6AM PDT

1300 1325	Turkey, Voice of Turkey	15450va
1300 1330	Egypt, R Cairo	17870as

1300 1330	Japan, R Japan NHK World	15735as
1300 1330	Serbia, International R Serbia	9635eu
1300 1357	North Korea, VO Korea	9335na 11710na
	13760eu 15245eu	
1300 1400	Anguilla, University Network	11775na
1300 1400	Australia, ABC NT Alice Springs	2310do
1300 1400	Australia, ABC NT Katherine	2485do
1300 1400	Australia, ABC/R Australia	6020pa 9580pa
	11945pa	
1300 1400	Bahrain, R Bahrain	6010me
1300 1400 Sun/DRM	Belgium, TDP Radio	6015na
1300 1400	Canada, CFRX Toronto ON	6070na
1300 1400	Canada, CFVP Calgary AB	6030na
1300 1400	Canada, CKZN St Johns NF	6160na
1300 1400	Canada, CKZU Vancouver BC	6160na
1300 1400	China, China R International	5995as
	9570na 9730as 9760pa	9765va
	9870as 11660as 11760pa	13610eu
	13755as 13790eu	
1300 1400 Sat/Sun	Germany, Mighty KBC Radio	6095eu
1300 1400	Indonesia, VO Indonesia	9526va
1300 1400	Italy, IRRS SW	15190va
1300 1400	Malaysia, RTM Kajang/Traxx FM	7295do
1300 1400	New Zealand, R New Zealand Intl	6170pa
1300 1400	Nigeria, VO Nigeria	9690af
1300 1400	Palau, T8WH/World Harvest R	9930as
1300 1400 DRM	Russia, VO Russia	9560as 12065as
1300 1400	Russia, VO Russia	12065as
1300 1400	South Korea, KBS World R	9570as
1300 1400	Tajikistan, VO Tajik	7245va
1300 1400	UK, BBC World Service	5875as 6190af
	6195as 9740as 11760me	15310as
	15420af 15575me 17640af	17790as
	17830af	
1300 1400	USA, Amer Forces Network/AFRTS	4319usb
	5446usb 5765usb 7811usb	12133usb
	12759usb 13362usb	
1300 1400	USA, BBG/Voice of America	7575as
1300 1400 Sat/Sun	USA, BBG/Voice of America	7575as
	9510as 9610as 12150as	
1300 1400	USA, FBN/WTJC Newport NC	9370na
1300 1400	USA, KJES Vado NM	11715na
1300 1400	USA, WBCQ Monticello ME	9330am
1300 1400	USA, WEWN/EWTN Irondale AL	15615as
1300 1400 Sat/Sun	USA, WHRI Cypress Creek SC	9795na
	9840am	
1300 1400	USA, WINB Red Lion PA	13570am
1300 1400	USA, WTWW Lebanon TN	9479va
1300 1400	USA, WWCR Nashville TN	7490af 9980af
	13845eu 15825eu	
1300 1400	USA, WWRB Manchester TN	9385na
1300 1400	USA, WYFR/Family R Worldwide	11540as
1300 1400	Zambia, Christian Voice	6065af
1300 1400	Zambia, CVC Intl/1 Africa	13590af
1330 1400 f	Clandestine, JSR/Shiokaze/Sea Breeze	5985as
1330 1400	India, AIR/External Svc	9690as 11620as
	13710as	
1330 1400	Vietnam, VO Vietnam/Overseas Svc	9840as
	12020as	

1400 UTC - 10AM EDT / 9AM CDT / 7AM PDT

1400 1430 f	Clandestine, JSR/Shiokaze/Sea Breeze	5985as
1400 1430	Japan, R Japan NHK World	11705as
	15735as	
1400 1430	Thailand, R Thailand World Svc	9395va
1400 1430 Sun	USA, Pan Amer Broadcasting	15205as
1400 1500	Anguilla, University Network	11775na
1400 1500	Australia, ABC NT Alice Springs	2310do
1400 1500	Australia, ABC NT Katherine	2485do
1400 1500	Australia, ABC NT Tennant Creek	2325do
1400 1500	Australia, ABC/R Australia	5995pa 9580pa
	11945pa	
1400 1500	Bahrain, R Bahrain	6010me
1400 1500 Sun	Canada, Bible Voice Broadcasting	17495as
1400 1500	Canada, CFRX Toronto ON	6070na

1400 1500	Canada, CFVP Calgary AB 6030na	
1400 1500	Canada, CKZN St Johns NF6160na	
1400 1500	Canada, CKZU Vancouver BC	6160na
1400 1500	China, China R International	5955as
	9765va 9870as 11665me 11675as	
	11765as 13710eu 13740na 13790eu	
	17630af	
1400 1500	Eqt Guinea, Pan American BC/R Africa	
	15190af	
1400 1500 Sat/Sun	Germany, Mighty KBC Radio	6095eu
1400 1500	India, AIR/External Svc	9690as 11620as
	13710as	
1400 1500	Italy, IRRS SW	15190va
1400 1500	Malaysia, RTM Kajang/Traxx FM	7295do
1400 1500	New Zealand, R New Zealand Intl	6170pa
1400 1500	Nigeria, VO Nigeria	9690af
1400 1500	Oman, R Sultanate of Oman	15140va
1400 1500 DRM	Russia, VO Russia	12095eu
1400 1500	Russia, VO Russia	4975va 9560as
	11500as 11840as	
1400 1500	South Korea, KBS World R	9570as
1400 1500	UK, BBC World Service	5845as 5875as
	6190af 6195as 9740as 11890as	
	12095af 13820me 15310as 17640af	
	17830af 21470af	
1400 1500	USA, Amer Forces Network/AFRTS	4319usb
	5446usb 5765usb 7811usb 12133usb	
	12759usb 13362usb	
1400 1500	USA, BBG/Voice of America	4930af
	6080af 15265af 15580af 17530af	
1400 1500 mtwhf	USA, BBG/Voice of America	7540as
	7575as 12150as	
1400 1500	USA, FBN/WTJC Newport NC	9370na
1400 1500	USA, Overcomer Ministry	9655eu
1400 1500	USA, WBCQ Monticello ME9330am	
1400 1500 Sat/Sun	USA, WBCQ Monticello ME15420am	
1400 1500	USA, WEWN/EWTN Irondale AL	15615as
1400 1500 Sat/Sun	USA, WHRI Cypress Creek SC	9795am
	9840am 21670va	
1400 1500	USA, WJHR Intl Milton FL	15550usb
1400 1500	USA, WTWW Lebanon TN	9479va
1400 1500	USA, WWCR Nashville TN	7490af 9980af
	13845eu 15825eu	
1400 1500	USA, WWRB Manchester TN	9385na
1400 1500	USA, WYFR/Family R Worldwide	11540as
1400 1500	Zambia, Christian Voice	6065af
1400 1500	Zambia, CVC Intl/1 Africa	13590af
1405 1435 Sat/Sun	Canada, Bible Voice Broadcasting	15270as
1415 1427	Nepal, R Nepal	5005do
1415 1430 mtwhfa	USA, Pan Amer Broadcasting	15205as
1420 1440	India, AIR/Itanagar	4990do
1420 1455	Swaziland, TWR Africa	4760af
1430 1445	India, AIR/Aizawl	5050do 7295do
1430 1445	India, AIR/Gangkok	4835do
1430 1445	India, AIR/Jeyapore	5040do
1430 1445	India, AIR/Mumbai	4840do 7240do
1430 1445 Sun	USA, Pan Amer Broadcasting	15205as
1430 1500	Australia, ABC/R Australia	9475as 11660as
1430 1500 Sat	Canada, Bible Voice Broadcasting	17495as
1430 1500	China, China Business R	6190do 7220do
1430 1500	China, China Natl R/CNR11	4905do
	4920do 6130do	
1430 1500	USA, WRMI/R Prague relay	9955ca
1445 1500	Australia, HCJB Global Australia	15340as
1450 1500	India, AIR/Itanagar	4990do
1450 1500	India, AIR/Kuresong	4895do

1500 UTC - 11AM EDT / 10AM CDT / 8AM PDT

1500 1515 Sun	Canada, Bible Voice Broadcasting	13740as
1500 1525 mhf	Guam, KTWR/TWR Asia	15200as
1500 1530	Australia, ABC/R Australia	11945pa
1500 1530	Australia, HCJB Global Australia	15340as
1500 1530	Vietnam, VO Vietnam/Overseas Svc	7285as
	9840as 12020as	
1500 1535 twas	Guam, KTWR/TWR Asia	15200as
1500 1550	New Zealand, R New Zealand Intl	6170pa
1500 1557	North Korea, VO Korea	9335na 11710na
	13760eu 15245eu	

1500 1600	Anguilla, University Network	11775na
1500 1600	Australia, ABC NT Alice Springs	2310do
1500 1600	Australia, ABC NT Katherine	2485do
1500 1600	Australia, ABC/R Australia	5940as 5995pa
	7240pa 9475as 11660as	
1500 1600	Bahrain, R Bahrain	6010me
1500 1600	Canada, CFRX Toronto ON	6070na
1500 1600	Canada, CFVP Calgary AB	6030na
1500 1600	Canada, CKZN St Johns NF6160na	
1500 1600	Canada, CKZU Vancouver BC	6160na
1500 1600	China, China R International	5955as
	6095me 7325as 7395as 9720me	
	9800as 9870as 11965eu 13640eu	
	13740na 17630af	
1500 1600 Sat	Clandestine, Sudan R Service	17745af
1500 1600	Eqt Guinea, Pan American BC/R Africa	
	15190af	
1500 1600 Sat/Sun	Germany, Mighty KBC Radio	6095eu
1500 1600 Sat	Italy, IRRS SW	15700va
1500 1600	Malaysia, RTM Kajang/Traxx FM	7295do
1500 1600	Nigeria, VO Nigeria	15120af
1500 1600	Russia, VO Russia	4975va 9560as
	11840as 15640me	
1500 1600	South Africa, Channel Africa	9625af
1500 1600	Uganda, Dunamis Shortwave	4750do
1500 1600	UK, BBC World Service	5845as 5875as
	6190af 6195as 7435af 9410as	
	9740as 11890as 12095af 13820me	
	15310as 15400af 17640af 17830af	
	21470af	
1500 1600	USA, Amer Forces Network/AFRTS	4319usb
	5446usb 5765usb 7811usb 12133usb	
	12759usb 13362usb	
1500 1600	USA, BBG/Voice of America	4930af
	6080af 6140as 7465as 7520as	
	9485as 9760as 12150as 13570me	
	15265af 15530me 15580af 17895af	
1500 1600	USA, FBN/WTJC Newport NC	9370na
1500 1600	USA, KNLS Anchor Point AK	9655as
1500 1600	USA, Overcomer Ministry	13810me
1500 1600	USA, WBCQ Monticello ME9330am	
1500 1600 Sat/Sun	USA, WBCQ Monticello ME15420am	
1500 1600	USA, WEWN/EWTN Irondale AL	15610eu
1500 1600 Sat/Sun	USA, WHRI Cypress Creek SC	9795am
	9840am	
1500 1600 Sun	USA, WHRI Cypress Creek SC	21630af
1500 1600	USA, WINB Red Lion PA	13570am
1500 1600	USA, WJHR Intl Milton FL	15550usb
1500 1600	USA, WTWW Lebanon TN	9479va
1500 1600	USA, WWCR Nashville TN	9980af 12160af
	13845eu 15825eu	
1500 1600	USA, WWRB Manchester TN	9385na
1500 1600	USA, WYFR/Family R Worldwide	6280as
	13690as 15520as	
1500 1600	Zambia, Christian Voice	6065af
1500 1600	Zambia, CVC Intl/1 Africa	13590af
1515 1530 Sat	Australia, HCJB Global Australia	15340as
1515 1530 f	Canada, Bible Voice Broadcasting	15275as
1525 1555 Sat/Sun	Swaziland, TWR Africa	4760af
1530 1545	India, AIR/Aizawl	5050do 7295do
1530 1545	India, AIR/Bhopal	4810do 7430do
1530 1545	India, AIR/Chennai	4920do
1530 1545	India, AIR/Guwahati	4940do
1530 1545	India, AIR/Hyderabad	4800do
1530 1545	India, AIR/Imphal	4775do
1530 1545	India, AIR/Itanagar	4990do
1530 1545	India, AIR/Jaipur	4910do 7325do
1530 1545	India, AIR/Jeyapore	5040do
1530 1545	India, AIR/Kuresong	4895do
1530 1545	India, AIR/Lucknow	4880do 7440do
1530 1545	India, AIR/Port Blair/Andaman & Nicobar	4760do
1530 1545	India, AIR/R Kashmir	4950do
1530 1545	India, AIR/Shillong	4970do
1530 1545	India, AIR/Shimla	4965do 6020do
1530 1545	India, AIR/Thiruvananthapuram	5010do
1530 1600 afghanistan	RTV Afghanistan	7200as
1530 1600	Australia, ABC/R Australia	11880pa
1530 1600 DRM	Belgium, The Disco Palace	15775as

1530 1600 h	Canada, Bible Voice Broadcasting	15275as
1530 1600 Sun	Clandestine, Sudan R Service	17745af
1530 1600 smtwa	Germany, AWR Europe	15255as
1530 1600 mtwas	Indonesia, AWR Asia/Pacific	15255as
1530 1600	Iran, VO Islamic Rep of Iran	11945va 13780va 13720al
1530 1600	Mongolia, Voice of Mongolia	12015as
1530 1600	Vatican City State, Vatican R	11850as 13765as 17520as
1530 1600 DRM	Vatican City State, Vatican R	17815as
1551 1600	New Zealand, R New Zealand Intl	7440pa
1551 1600 DRM	New Zealand, R New Zealand Intl	6170pa

1600 UTC - 12PM EDT / 11AM CDT / 9AM PDT

1600 1627	Iran, VO Islamic Rep of Iran	11945va 13780va 13720al
1600 1630	Australia, ABC/R Australia	9540as
1600 1630 DRM	Belgium, The Disco Palace	15775as
1600 1630	Vietnam, VO Vietnam/Overseas Svc	7220me 9550me 9730eu
1600 1657	North Korea, VO Korea	3560eu 9990va 11545va
1600 1700	Anguilla, University Network	11775na
1600 1700	Australia, ABC NT Alice Springs	2310do
1600 1700	Australia, ABC NT Katherine	2485do
1600 1700	Australia, ABC/R Australia	5940as 5995pa 7240pa 9475as 11660as 11880pa
1600 1700	Bahrain, R Bahrain	6010me
1600 1700	Canada, CFRX Toronto ON	6070na
1600 1700	Canada, CFVP Calgary AB	6030na
1600 1700	Canada, CKZN St Johns NF	6160na
1600 1700	Canada, CKZU Vancouver BC	6160na
1600 1700	China, China R International	6060as 7235as 7420af 9570af 11900af 11940eu 11965eu 13760eu
1600 1700	Egypt, R Cairo	15345af
1600 1700	Eqt Guinea, Pan American BC/R Africa	15190af
1600 1700	Ethiopia, R Ethiopia	7235va 9560va
1600 1700 Sat/Sun	Germany, Mighty KBC Radio	6095eu
1600 1700	Malaysia, RTM Kajang/Traxx FM	7295do
1600 1700 DRM	New Zealand, R New Zealand Intl	6170pa
1600 1700	New Zealand, R New Zealand Intl	7440pa
1600 1700	Palau, T8WH/World Harvest R	15530as
1600 1700 DRM	Russia, VO Russia	6070as 7370eu
1600 1700	Russia, VO Russia	4975as 7285me 11985me
1600 1700	South Korea, KBS World R	9515eu 9640as
1600 1700	Taiwan, R Taiwan Intl	9435as 15485as
1600 1700	Uganda, Dunamis Shortwave	4750do
1600 1700	UK, BBC World Service	3255af 5845as 5975as 6190af 9410as 11890as 12095af 13820me 15400af 17795af 17830af 21470af
1600 1700	USA, Amer Forces Network/AFRTS	4319usb 5446usb 5765usb 7811usb 12133usb 12759usb 13362usb
1600 1700	USA, BBG/Voice of America	4930af 6080af 7465as 12080af 13570af 15470af 15580af
1600 1700	USA, FBN/WTJC Newport NC	9370na
1600 1700	USA, Overcomer Ministry	15425as
1600 1700	USA, WBCQ Monticello ME	9330am
1600 1700 Sat/Sun	USA, WBCQ Monticello ME	15420am
1600 1700	USA, WEWN/EWTN Irondale AL	15610eu
1600 1700 Sat/Sun	USA, WHRI Cypress Creek SC	9795am
1600 1700	USA, WHRI Cypress Creek SC	9840na 11630af
1600 1700	USA, WINB Red Lion PA	13570am
1600 1700	USA, WJHR Intl Milton FL	15550usb
1600 1700	USA, WTWW Lebanon TN	9479va
1600 1700	USA, WWCR Nashville TN	9980af 12160af 13845eu 15825eu
1600 1700	USA, WWRB Manchester TN	9385na
1600 1700	USA, WYFR/Family R Worldwide	11850as
1600 1700	Zambia, Christian Voice	6065af
1600 1700	Zambia, CVC Intl/1 Africa	13590af

1615 1630	Vatican City State, Vatican R	15595va
1630 1700	Clandestine, Sudan R Service	17745af
1630 1700	Indonesia, AWR Asia/Pacific	11740as
1630 1700	Turkey, Voice of Turkey	15520as
1630 1700	USA, BBG/Voice of America	9490af 11655af 13800af
1645 1700	Canada, Bible Voice Broadcasting	15215me

1700 UTC - 1PM EDT / 12PM CDT / 10AM PDT

1700 1710	Pakistan, Azad Kashmir R	3975do 4790do
1700 1710	Pakistan, PBC/R Pakistan	11575eu
1700 1715 mf	Canada, Bible Voice Broadcasting	15215me
1700 1720 h	Canada, Bible Voice Broadcasting	15215me
1700 1725	Turkey, Voice of Turkey	15520as
1700 1730	Australia, ABC/R Australia	11660as
1700 1730	USA, BBG/Voice of America	6080af 11795va 17895af
1700 1730	Vietnam, VO Vietnam/Overseas Svc	9625eu
1700 1750 DRM	New Zealand, R New Zealand Intl	6170pa
1700 1750	New Zealand, R New Zealand Intl	7440pa
1700 1755	South Africa, Channel Africa	15235af
1700 1756 DRM	Romania, R Romania Intl	9535eu
1700 1756	Romania, R Romania Intl	11740eu 11740eu
1700 1800	Anguilla, University Network	11775na
1700 1800	Australia, ABC NT Alice Springs	2310do
1700 1800	Australia, ABC NT Katherine	2485do
1700 1800	Australia, ABC/R Australia	5995pa 9475as 9500pa 9580pa 11880pa
1700 1800	Bahrain, R Bahrain	6010me
1700 1800asm	Canada, Bible Voice Broadcasting	15215me
1700 1800	Canada, CFRX Toronto ON	6070na
1700 1800	Canada, CFVP Calgary AB	6030na
1700 1800	Canada, CKZN St Johns NF	6160na
1700 1800	Canada, CKZU Vancouver BC	6160na
1700 1800	China, China R International	6090as 6140as 6145eu 6165me 7235as 7265af 7410as 7420as 9570af 9695eu 11900af 13760eu
1700 1800	Egypt, R Cairo	15345af
1700 1800	Eqt Guinea, Pan American BC/R Africa	15190af
1700 1800	Malaysia, RTM Kajang/Traxx FM	7295do
1700 1800	Poland, Polish R/External Svc	9955na
1700 1800 DRM	Russia, VO Russia	7370eu
1700 1800	Russia, VO Russia	4975va 7285va 11985af 12040eu
1700 1800	Swaziland, TWR Africa	3200af
1700 1800	Taiwan, R Taiwan Intl	15690af
1700 1800	UK, BBC World Service	3255af 5845as 5975as 6190af 9410as 11890as 12095af 15400af 15420af 17640af 17795af 17830af
1700 1800	USA, Amer Forces Network/AFRTS	4319usb 5446usb 5765usb 7811usb 12133usb 12759usb 13362usb
1700 1800	USA, BBG/Voice of America	11795af 15580af
1700 1800	USA, FBN/WTJC Newport NC	9370na
1700 1800	USA, Overcomer Ministry	15425as
1700 1800	USA, WBCQ Monticello ME	9330am 15420am
1700 1800	USA, WEWN/EWTN Irondale AL	15610eu
1700 1800	USA, WHRI Cypress Creek SC	9840na 21630af
1700 1800	USA, WINB Red Lion PA	13570am
1700 1800	USA, WJHR Intl Milton FL	15550usb
1700 1800	USA, WTWW Lebanon TN	9479va
1700 1800	USA, WWCR Nashville TN	9980af 12160af 13845eu 15825eu
1700 1800	USA, WWRB Manchester TN	9385na
1700 1800	USA, WYFR/Family R Worldwide	17545af 7395af
1700 1800	Zambia, Christian Voice	4965as
1700 1800	Zambia, CVC Intl/1 Africa	13590af
1720 1740 Sat/Sun	USA, BBG/Voice of America/Studio	74930af 7210af 9725af
1730 1745 h	Canada, Bible Voice Broadcasting	15215me
1730 1745	India, AIR/Bhopal	4810do 7430do

1730 1745	India, AIR/Chennai	4920do	
1730 1745	India, AIR/Guwahati	4940do	
1730 1745	India, AIR/Hyderabad	4800do	
1730 1745	India, AIR/Imphal	4775do	
1730 1745	India, AIR/Jaipur 4910do	7325do	
1730 1745	India, AIR/Kuresong	4895do	
1730 1745	India, AIR/Lucknow	4880do	7440do
1730 1745	India, AIR/R Kashmir	4950do	
1730 1745	India, AIR/Shimla	4965do	6020do
1730 1745	India, AIR/Thiruvananthapuram	5010do	
1730 1800	Australia, ABC/R Australia	6080pa	
1730 1800 Sun	Italy, IRRS SW	7290va	
1730 1800 m	South Africa, R Mirror Intl	3230af	
1730 1800	USA, BBG/Voice of America	6080af	
	12015va	17895af	
1730 1800 mtwh	USA, BBG/Voice of America/Studio 7	4930af	
	7210af	9725af	
1730 1800	Vatican City State, Vatican R1	11625af	13765af
	15570af		
1745 1800 Sat	Canada, Bible Voice Broadcasting	17515af	
1745 1800 DRM	India, AIR/External Svc	9950eu	
1745 1800	India, AIR/External Svc	7400af	7550eu
	9415af	11580af	11670as
	13695af		11935af
1751 1800	New Zealand, R New Zealand Intl	9615pa	
1751 1800 DRM	New Zealand, R New Zealand Intl	7440pa	

1800 UTC - 2PM EDT / 1PM CDT / 11AM PDT

1800 1830 w	Austria, AWR Europe	15325af	
1800 1830	Japan, R Japan NHK World	15720af	
1800 1830	South Africa, AWR Africa	3215af	3345af
1800 1830 m	South Africa, R Mirror Intl	3230af	
1800 1830	Tanzania, Zanzibar BC/VO Tanzania		11735do
1800 1830	UK, BBC World Service	5850as	5975as
1800 1830	USA, BBG/Voice of America	6080af	
	17895af		
1800 1830 Sat/Sun	USA, BBG/Voice of America	4930af	
1800 1830	USA, BBG/Voice of America	9850af	
1800 1836 DRM	New Zealand, R New Zealand Intl	7440pa	
1800 1836	New Zealand, R New Zealand Intl	9615pa	
1800 1857	North Korea, VO Korea	13760eu	15245eu
1800 1900	Anguilla, University Network		11775na
1800 1900 mtwhf	Argentina, RAE	15345eu	
1800 1900	Australia, ABC NT Alice Springs	2310do	
1800 1900	Australia, ABC NT Katherine	2485do	
1800 1900	Australia, ABC/R Australia	6080pa	9500pa
	9580pa	9710pa	11880pa
1800 1900	Bahrain, R Bahrain	6010me	
1800 1900 Sat	Canada, Bible Voice Broadcasting	9430me	
1800 1900 Sun	Canada, Bible Voice Broadcasting	6130eu	
	15215me		
1800 1900	Canada, CFRX Toronto ON	6070na	
1800 1900	Canada, CFVP Calgary AB	6030na	
1800 1900	Canada, CKZN St Johns NF	6160na	
1800 1900	Canada, CKZU Vancouver BC	6160na	
1800 1900	China, China R International	6175eu	
	9600eu	13760eu	
1800 1900 mtwhfa	Ecuador, HCJB/LV de los Andes	3995eu	
1800 1900	Eq Guinea, Pan American BC/R Africa		
	15190af		
1800 1900 DRM	India, AIR/External Svc	9950eu	
1800 1900	India, AIR/External Svc	7400af	7550as
	9415af	9445af	11580af
	11935af	13695af	11670eu
1800 1900 fa	Italy, IRRS SW	7290va	
1800 1900	Kuwait, R Kuwait	15540eu	
1800 1900	Malaysia, RTM Kajang/Traxx FM		7295do
1800 1900 DRM	Russia, VO Russia	7370eu	9880eu
1800 1900	Russia, VO Russia	4975me	9900va
	12040eu		
1800 1900	South Korea, KBS World R	7275eu	
1800 1900	Swaziland, TWR Africa	3200af	9500af
1800 1900	Taiwan, R Taiwan Intl	6155eu	
1800 1900	UK, BBC World Service	3255af	5875me
	5950as	6190af	11810af
	15400af	15420af	17795af

1800 1900	USA, Amer Forces Network/AFRTS	4319usb	
	5446usb	5765usb	7811usb
	12759usb	13362usb	12133usb
1800 1900	USA, BBG/Voice of America	12015af	
	15580af		
1800 1900	USA, FBN/WTJC Newport NC	9370na	
1800 1900	USA, KJES Vado NM	15385na	
1800 1900	USA, WBCQ Monticello ME	9330am	15420am
1800 1900	USA, WEWN/EWTN Irondale AL	15610af	
1800 1900	USA, WHRI Cypress Creek SC	9840na	
	21630af		
1800 1900	USA, WINB Red Lion PA	13570am	
1800 1900	USA, WJHR Intl Milton FL	15550usb	
1800 1900	USA, WTWV Lebanon TN	9479va	
1800 1900	USA, WWCR Nashville TN	9980af	12160af
	13845eu	15825eu	
1800 1900	USA, WWRB Manchester TN	9385na	
1800 1900	USA, WYFR/Family R Worldwide	5905af	
	9610af	9925af	13750af
1800 1900	Zambia, Christian Voice	4965af	
1800 1900	Zambia, CVC Intl/1 Africa	13590af	
1815 1845 Sun	Canada, Bible Voice Broadcasting	6130eu	
	9430me		
1830 1900 f	Canada, Bible Voice Broadcasting	17515af	
1830 1900 Sun	Italy, IRRS SW	7290va	
1830 1900 mtwhf	Moldova, R PMR/Pridnestrovye	9665eu	
1830 1900 DRM/mtwhf	Nigeria, VO Nigeria	15120af	
1830 1900	Serbia, International R Serbia		6100eu
1830 1900	South Africa, AWR Africa	11840af	
1830 1900	Turkey, Voice of Turkey	9785va	
1830 1900	UK, BBC World Service	9410af	
1830 1900	USA, BBG/Voice of America	4930af	
	6080af	9850af	
1837 1900	New Zealand, R New Zealand Intl	9615pa	
1837 1900 DRM	New Zealand, R New Zealand Intl	9890pa	

1900 UTC - 3PM EDT / 2PM CDT / 12PM PDT

1900 1925	Turkey, Voice of Turkey	9785va	
1900 1927	Germany, Deutsche Welle	9735af	
1900 1930 f	Canada, Bible Voice Broadcasting	17515af	
1900 1930	Germany, Deutsche Welle	7365af	11800af
1900 1930	USA, BBG/Voice of America	9850af	
1900 1930	Vietnam, VO Vietnam/Overseas Svc	7280eu	
	9730eu		
1900 1945 DRM	India, AIR/External Svc	9950eu	
1900 1945	India, AIR/External Svc	7400af	7550eu
	9415af	9445af	11580af
	11935af	13695af	11670eu
1900 1950 DRM	New Zealand, R New Zealand Intl	9890pa	
1900 1950	New Zealand, R New Zealand Intl	9615pa	
1900 1957	North Korea, VO Korea	3560eu	7210af
	9975va	11535va	11910af
1900 2000	Anguilla, University Network		11775na
1900 2000	Australia, ABC NT Alice Springs	2310do	
1900 2000	Australia, ABC NT Katherine	2485do	
1900 2000	Australia, ABC/R Australia	6080pa	9475as
	9500pa	9580pa	9710pa
	11880pa		11660pa
1900 2000	Bahrain, R Bahrain	6010me	
1900 2000	Canada, CFRX Toronto ON	6070na	
1900 2000	Canada, CFVP Calgary AB	6030na	
1900 2000	Canada, CKZN St Johns NF	6160na	
1900 2000	Canada, CKZU Vancouver BC	6160na	
1900 2000	China, China R International	7295va	
	9435af	9440af	
1900 2000	Cuba, R Havana Cuba	11760am	
1900 2000	Egypt, R Cairo	15290af	
1900 2000	Eq Guinea, Pan American BC/R Africa		
	15190af		
1900 2000	Indonesia, VO Indonesia	9526va	
1900 2000	Kuwait, R Kuwait	15540eu	
1900 2000	Malaysia, RTM Kajang/Traxx FM	7295do	
1900 2000	Micronesia, V6MP/Cross R/Pohnpei		4755as
1900 2000 DRM/mtwhf	Nigeria, VO Nigeria	15120af	
1900 2000 DRM	Russia, VO Russia	6155eu	
1900 2000	Russia, VO Russia	12040eu	
1900 2000 mtwhf	Spain, R Exterior de Espana	9665af	11620af

1900 2000	Swaziland, TWR Africa	3200af	
1900 2000	Thailand, R Thailand World Svc	7205eu	
1900 2000	UK, BBC World Service	3255af	5875me
	5950as	6005af	6190af
	11810af	12095af	15400af
1900 2000	USA, Amer Forces Network/AFRTS	4319usb	
	5446usb	5765usb	7811usb
	12759usb	13362usb	12133usb
1900 2000	USA, BBG/Voice of America	4930af	
	4940af	6080af	7485me
	15580af		9490me
1900 2000	USA, FBN/WTJC Newport NC	9370na	
1900 2000	USA, Overcomer Ministry	9400eu	
1900 2000	USA, WBCQ Monticello ME	9330am	15420am
1900 2000	USA, WEWN/EWTN Irondale AL	15610af	
1900 2000	USA, WHRI Cypress Creek SC	9840na	
	21630af		
1900 2000	USA, WINB Red Lion PA	13570am	
1900 2000	USA, WJHR Intl Milton FL	15550usb	
1900 2000	USA, WTWV Lebanon TN	9479va	
1900 2000	USA, WWCR Nashville TN	9980af	12160af
	13845eu	15825eu	
1900 2000	USA, WWRB Manchester TN	9385na	
1900 2000	USA, WYFR/Family R Worldwide	9775af	
	9925af		
1900 2000	Zambia, Christian Voice	4965af	
1900 2000	Zambia, CVC Intl/1 Africa	13590af	
1905 1920 Sat	Mali, ORTM/R Mali	9635do	
1930 1957	Germany, Deutsche Welle	7365af	
1930 2000	Eqt Guinea, Pan American BC/R Africa	9515af	
1930 2000	Germany, Deutsche Welle	11800af	
1930 2000	Iran, VO Islamic Rep of Iran	9540eu	9800eu
	11750af	11885af	
1930 2000 Sat	USA, Pan Amer Broadcasting	9515af	
1951 2000	New Zealand, R New Zealand Intl	11725pa	
1951 2000 DRM	New Zealand, R New Zealand Intl	15720pa	

2000 UTC - 4PM EDT / 3PM CDT / 1PM PDT

2000 2027	Iran, VO Islamic Rep of Iran	9540eu	9800eu
	11750af	11885af	
2000 2030 mtwhfa	Albania, R Tirana	7465eu	
2000 2030	Australia, ABC/R Australia	6080pa	9500pa
2000 2030	Egypt, R Cairo	15290af	
2000 2030	Eqt Guinea, Pan American BC/R Africa	9515af	
2000 2030 Sat	Swaziland, TWR Africa	3200af	
2000 2030	USA, BBG/Voice of America	4930af	
	6080af		
2000 2030	Vatican City State, Vatican R	9755af	11625af
2000 2057	Germany, Deutsche Welle	9490af	
2000 2100	Anguilla, University Network	11775na	
2000 2100	Australia, ABC NT Alice Springs	2310do	
2000 2100	Australia, ABC NT Katherine	2485do	
2000 2100	Australia, ABC NT Tennant Creek	2325do	
2000 2100	Australia, ABC/R Australia	9580pa	11650pa
	11660pa	12080pa	15515pa
2000 2100	Bahrain, R Bahrain	6010me	
2000 2100	Belarus, R Belarus	7255eu	11730eu
2000 2100 DRM	Belgium, The Disco Palace	17875na	
2000 2100	Canada, CFRX Toronto ON	6070na	
2000 2100	Canada, CFVP Calgary AB	6030na	
2000 2100	Canada, CKZN St Johns NF	6160na	
2000 2100	Canada, CKZU Vancouver BC	6160na	
2000 2100	China, China R International	5960eu	
	5985af	7285eu	7295va
	9440af	9600eu	7415eu
2000 2100 f	Clandestine, JSR/Shiokaze/Sea Breeze	5910as	
2000 2100	Eqt Guinea, Pan American BC/R Africa	15190af	
2000 2100	Germany, Deutsche Welle	6150af	11800af
2000 2100	Kuwait, R Kuwait	15540eu	
2000 2100	Malaysia, RTM Kajang/Traxx FM	7295do	
2000 2100	Micronesia, V6MP/Cross R/Pohnpei	4755as	
2000 2100 DRM	New Zealand, R New Zealand Intl	15720pa	
2000 2100	New Zealand, R New Zealand Intl	11725pa	

2000 2100 DRM	Russia, VO Russia	6155eu	
2000 2100	Russia, VO Russia	12040eu	
2000 2100	South Africa, CVC 1 Africa R	9505af	
	13590af		
2000 2100	UK, BBC World Service	3255af	6005af
	6190af	9410af	9855af
	12095af	15400af	11810af
2000 2100	USA, Amer Forces Network/AFRTS	4319usb	
	5446usb	5765usb	7811usb
	12759usb	13362usb	12133usb
2000 2100	USA, BBG/Voice of America	4930af	
	7485me	15580af	
2000 2100 mtwhf	USA, BBG/Voice of America	9480me	
2000 2100	USA, FBN/WTJC Newport NC	9370na	
2000 2100	USA, Overcomer Ministry	9400eu	
2000 2100	USA, WBCQ Monticello ME	7490am	9330am
	15420am		
2000 2100	USA, WEWN/EWTN Irondale AL	15610af	
2000 2100 mtwhfa	USA, WHRI Cypress Creek SC	21630af	
2000 2100	USA, WHRI Cypress Creek SC	9840na	17510va
2000 2100	USA, WINB Red Lion PA	13570am	
2000 2100	USA, WJHR Intl Milton FL	15550usb	
2000 2100	USA, WTWV Lebanon TN	9479va	
2000 2100	USA, WWCR Nashville TN	9980af	12160af
	13845eu	15825eu	
2000 2100	USA, WWRB Manchester TN	9385na	
2000 2100	USA, WYFR/Family R Worldwide	15195af	
2000 2100	Zambia, Christian Voice	4965af	
2000 2100	Zambia, CVC Intl/1 Africa	9505as	
2030 2045	Thailand, R Thailand World Svc	9680eu	
2030 2056 DRM	Romania, R Romania Intl	9700eu	
2030 2056	Romania, R Romania Intl	11880na	13800na
	15220na		
2030 2100	Australia, ABC/R Australia	9500pa	11695as
	12080pa		
2030 2100 mtwhf	Moldova, R PMR/Pridnestrovyje	9665eu	
2030 2100	Turkey, Voice of Turkey	7205va	
2030 2100	USA, BBG/Voice of America	6080af	
	7555as		
2030 2100 Sat/Sun	USA, BBG/Voice of America	4940af	
2030 2100	Vietnam, VO Vietnam/Overseas Svc	7220me	
	7280eu	9730me	9730eu
2045 2100	India, AIR/External Svc	7550eu	9445eu
	9910pa	11620pa	11670eu
2045 2100 DRM	India, AIR/External Svc	9950eu	11715pa

2100 UTC - 5PM EDT / 4PM CDT / 2PM PDT

2100 2125	Turkey, Voice of Turkey	7205va	
2100 2130	Australia, ABC NT Alice Springs	2310do	
2100 2130	Australia, ABC NT Katherine	2485do	
2100 2130	Australia, ABC NT Tennant Creek	2325do	
2100 2130	Austria, AWR Europe	11955af	
2100 2130	Serbia, International R Serbia	6100eu	
2100 2130	South Korea, KBS World R	3955eu	
2100 2150	New Zealand, R New Zealand Intl	11725pa	
2100 2150 DRM	New Zealand, R New Zealand Intl	15720pa	
2100 2157	North Korea, VO Korea	13760eu	15245eu
2100 2200	Angola, Angolan National R	7217af	
2100 2200	Anguilla, University Network	11775na	
2100 2200	Australia, ABC/R Australia	9500pa	11695as
	13630pa	15515pa	11650pa
	21740pa		
2100 2200	Bahrain, R Bahrain	6010me	
2100 2200	Belarus, R Belarus	7255eu	11730eu
2100 2200	Canada, CFRX Toronto ON	6070na	
2100 2200	Canada, CFVP Calgary AB	6030na	
2100 2200	Canada, CKZN St Johns NF	6160na	
2100 2200	Canada, CKZU Vancouver BC	6160na	
2100 2200	China, China R International	5960eu	
	7205af	7285eu	7325af
	9600eu		7415eu
2100 2200	Eqt Guinea, Pan American BC/R Africa	15190af	
2100 2200	Germany, Deutsche Welle	11800af	11830af
	11865af		
2100 2200	India, AIR/External Svc	7550eu	9445eu
	9910pa	11620pa	11670eu
			11715pa

2100 2200 DRM	India, AIR/External Svc	9950eu	
2100 2200	Malaysia, RTM Kajang/Traxx FM	7295do	
2100 2200	Micronesia, V6MP/Cross R/Pohnpei	4755as	
2100 2200 DRM	Russia, VO Russia	6155eu	
2100 2200	South Africa, CVC 1 Africa R	9505af	
	13590af		
2100 2200 Sat/Sun	Spain, R Exterior de Espana	9650eu	
2100 2200	Syria, R Damascus	9330va	
2100 2200	UK, BBC World Service	3255af	3915as
	5875as	5905af	6005af
	6195va	9410af	12095af
2100 2200	USA, Amer Forces Network/AFRTS	4319usb	
	5446usb	5765usb	7811usb
	12759usb	13362usb	
2100 2200	USA, BBG/Voice of America	6080af	
	7555as	15580af	
2100 2200	USA, FBN/WTJC Newport NC	9370na	
2100 2200	USA, Overcomer Ministry	9400eu	
2100 2200	USA, WBCQ Monticello ME7490am	9330am	
2100 2200	USA, WEWN/EWTN Irondale AL	15610af	
2100 2200	USA, WHRI Cypress Creek SC	17510va	
2100 2200	USA, WINB Red Lion PA	9265am	
2100 2200	USA, WJHR Intl Milton FL	15550usb	
2100 2200	USA, WTWW Lebanon TN	9479va	
2100 2200	USA, WWCR Nashville TN	6875eu	9350af
	9980af	13845eu	
2100 2200	USA, WWRB Manchester TN	9385na	
2100 2200	USA, WYFR/Family R Worldwide	12070af	
2100 2200	Zambia, Christian Voice	4965af	
2100 2200	Zambia, CVC Intl/1 Africa	9505as	
2115 2200	Egypt, R Cairo	11890eu	
2130 2200	Australia, ABC NT Alice Springs	4835do	
2130 2200	Australia, ABC NT Katherine	5025do	
2145 2200	India, AIR/R Kashmir	4950do	
2151 2200	New Zealand, R New Zealand Intl	15720pa	
2151 2200 DRM	New Zealand, R New Zealand Intl	17675pa	

2200 UTC - 6PM EDT / 5PM CDT / 3PM PDT

2200 2230	India, AIR/External Svc	7550eu	9445eu
	9910pa	11620pa	11670eu
2200 2230 DRM	India, AIR/External Svc	9950as	
2200 2245	Egypt, R Cairo	11890eu	
2200 2255	Turkey, Voice of Turkey	9830va	
2200 2256	Romania, R Romania Intl	7435eu	9540eu
	9790eu	11940eu	
2200 2300	Anguilla, University Network	6090na	
2200 2300	Australia, ABC NT Alice Springs	4835do	
2200 2300	Australia, ABC NT Katherine	5025do	
2200 2300	Australia, ABC/R Australia	9855as	12080pa
	13630pa	15230pa	15240as
	15515pa	21740pa	
2200 2300	Bahrain, R Bahrain	6010me	
2200 2300	Canada, CFRX Toronto ON	6070na	
2200 2300	Canada, CFVP Calgary AB	6030na	
2200 2300	Canada, CKZN St Johns NF6160na		
2200 2300	Canada, CKZU Vancouver BC	6160na	
2200 2300	China, China R International	9590as	
2200 2300	Eqt Guinea, Pan American BC/R Africa	15190af	
2200 2300	Malaysia, RTM Kajang/Traxx FM	7295do	
2200 2300	Micronesia, V6MP/Cross R/Pohnpei	4755as	
2200 2300	New Zealand, R New Zealand Intl	15720pa	
2200 2300 DRM	New Zealand, R New Zealand Intl	17675pa	
2200 2300 Sat	Palau, T8WH/World Harvest R	9930as	
2200 2300	Russia, VO Russia	9800va	
2200 2300	UK, BBC World Service	3915as	5875as
	5905as	6195as	7490as
	9730af	9740as	12095af
2200 2300	USA, Amer Forces Network/AFRTS	4319usb	
	5446usb	5765usb	7811usb
	12759usb	13362usb	
2200 2300	USA, BBG/Voice of America	5755as	
2200 2300 mtwhs	USA, BBG/Voice of America	5895as	
	5915as	7480as	7575as
2200 2300	USA, FBN/WTJC Newport NC	9370na	
2200 2300	USA, Overcomer Ministry	9400as	
2200 2300	USA, WBCQ Monticello ME7490am	9330am	

2200 2300	USA, WEWN/EWTN Irondale AL	15610me	
2200 2300	USA, WHRI Cypress Creek SC	11775va	
	13620na	17510va	
2200 2300 twhfas	USA, WINB Red Lion PA	9265am	
2200 2300	USA, WTWW Lebanon TN	9479va	
2200 2300	USA, WWCR Nashville TN	6875eu	9350af
	9980af	13845eu	
2200 2300	USA, WWRB Manchester TN	9385na	
2200 2300	Zambia, Christian Voice	4965af	
2215 2300	USA, WYFR/Family R Worldwide	6145va	
2230 2300	China, Xizang PBS	4905do	
2230 2300	Indonesia, AWR Asia/Pacific	9730as	
2230 2300 mtwhf	Moldova, R PMR/Pridnestrovye	9665eu	
2230 2300	USA, BBG/Voice of America	7460as	
	9570as	11840as	15340as
2230 2300	USA, WYFR/Family R Worldwide	6145na	
	11580af	15255af	
2245 2300	India, AIR/External Svc	6055as	9705as
	9950as	11670as	13605as
2245 2300 DRM	India, AIR/External Svc	11645as	
2245 2300	India, AIR/R Kashmir	4950do	

2300 UTC - 7PM EDT / 6PM CDT / 4PM PDT

2300 0000	Anguilla, University Network	6090na	
2300 0000	Australia, ABC NT Alice Springs	4835do	
2300 0000	Australia, ABC NT Katherine	5025do	
2300 0000	Australia, ABC/R Australia	9855as	12080pa
	13630pa	15230pa	15415pa
	17795pa	19000pa	21740pa
2300 0000	Bahrain, R Bahrain	6010me	
2300 0000	Canada, CFRX Toronto ON	6070na	
2300 0000	Canada, CFVP Calgary AB	6030na	
2300 0000	Canada, CKZN St Johns NF6160na		
2300 0000	Canada, CKZU Vancouver BC	6160na	
2300 0000	China, China R International	9590as	
	5990ca	6145na	7350eu
	9610as	11690as	11790as
2300 0000	Cuba, R Havana Cuba	5040va	
2300 0000	Egypt, R Cairo	9965na	
2300 0000	India, AIR/External Svc	6055as	9705as
	9950as	11670as	13605as
2300 0000 DRM	India, AIR/External Svc	11645as	
2300 0000	Malaysia, RTM Kajang/Traxx FM	7295do	
2300 0000	Micronesia, V6MP/Cross R/Pohnpei	4755as	
2300 0000	New Zealand, R New Zealand Intl	15720pa	
2300 0000 DRM	New Zealand, R New Zealand Intl	17675pa	
2300 0000	Russia, VO Russia	9665va	9800va
2300 0000	Spain, R Exterior de Espana	6055na	
2300 0000	UK, BBC World Service	3915as	6195as
	7490as	9580as	9740as
	11850as	12010as	
2300 0000	USA, Amer Forces Network/AFRTS	4319usb	
	5446usb	5765usb	7811usb
	12759usb	13362usb	
2300 0000	USA, BBG/Voice of America	5895as	
	5910as	7460as	7555as
	9570as	11840as	12150as
2300 0000	USA, FBN/WTJC Newport NC	9370na	
2300 0000	USA, WBCQ Monticello ME7490am	9330am	
2300 0000 Sat/Sun	USA, WBCQ Monticello ME5110am		
2300 0000	USA, WEWN/EWTN Irondale AL	15610me	
2300 0000	USA, WHRI Cypress Creek SC	13620na	
	17510va		
2300 0000 Sun	USA, WHRI Cypress Creek SC	11775va	
2300 0000 mtwhfs	USA, WHRI Cypress Creek SC	7315ca	
2300 0000	USA, WINB Red Lion PA	9265am	
2300 0000	USA, WTWW Lebanon TN	9479va	
2300 0000	USA, WWCR Nashville TN	6875eu	9350af
	9980af	13845eu	
2300 0000	USA, WWRB Manchester TN	9385na	
2300 0000	USA, WYFR/Family R Worldwide	6145na	
	15255sa	11580sa	
2300 0000	Zambia, Christian Voice	4965af	
2300 2330	Australia, ABC/R Australia	15240as	
2330 0000	Australia, ABC/R Australia	17750as	
2330 0000	Vietnam, VO Vietnam/Overseas Svc	9840as	
	12020as		



MTXTRA

Shortwave Broadcast Guide

SPANISH

The following language schedule is extracted from our new MTXtra Shortwave Broadcast Guide pdf which is a free download to all MTXpress subscribers. This new online Shortwave Broadcast Guide has more than 9,100 station entries that include all languages being broadcasts via shortwave radio worldwide, sorted by time and updated monthly.

0400 UTC - 12AM EDT / 11PM CDT / 9PM PDT

0400 0430	Japan, R Japan NHK World	6195sa
0400 0430	Vietnam, VO Vietnam/Overseas Svc	6175na
0400 0500 fa	Bolivia, R Fides	6155do
0400 0500	Colombia, La Voz de tu Conciencia	6010do
0400 0500	Colombia, R Alcaravan	5910do
0400 0500	Colombia, Salem Stereo	14950do
0400 0500	Cuba, R Havana Cuba	5040va 6060na
	6120ca 9810ca	11760am
0400 0500	Cuba, R Rebelde 5025na	
0400 0500	Ecuador, HCJB/LV de los Andes	6050sa
0400 0500	Honduras, HRMI/ R Misiones Intl	3340do
0400 0500	Mexico, R Educacion	6185do
0400 0500	Mexico, R Mil Onda Corta	6010do
0400 0500	Mexico, R Transcontinental de America	4800do
0400 0500	Mexico, R Universidad	6045do
0400 0500	Peru, R Tawantinsuyo	6174do
0400 0500	Peru, R Union	6115do
0400 0500	Peru, R Victoria	6020do 9720do
0400 0500	Peru, R Vision	4790do
0400 0500	Spain, R Exterior de Espana	3350ca 5995sa
	6055na 6125ca	9535ca 9620sa
	9630na	
0400 0500	Taiwan, R Taiwan Intl	7570ca
0400 0500 twhf	USA, BBG/R Marti	6030ca 7405ca
0400 0500	USA, WEWN/EWTN Irontdale AL	5810ca
	11870sa	
0400 0500	USA, WYFR/Family R Worldwide	11740ca

0500 UTC - 1AM EDT / 12AM CDT / 10PM PDT

0500 0530	Japan, R Japan NHK World	6080ca
0500 0557	North Korea, Korean Central BC Sta	11735ca
	13760sa	15180sa
0500 0600	Colombia, La Voz de tu Conciencia	6010do
0500 0600	Colombia, R Alcaravan	5910do
0500 0600	Colombia, Salem Stereo	14950do
0500 0600	Cuba, R Havana Cuba	9810ca
0500 0600	Cuba, R Rebelde 5025na	
0500 0600	Eqt Guinea, R Nacional/Bata	5005do
0500 0600	Eqt Guinea, R Nacional/Malabo	6250do
0500 0600	Mexico, R Educacion	6185do
0500 0600	Mexico, R Mil Onda Corta	6010do
0500 0600	Mexico, R Transcontinental de America	4800do
0500 0600 DRM	North Korea, Voice of Korea	3560as
0500 0600	Peru, R Tawantinsuyo	6174do
0500 0600	Peru, R Union	6115do
0500 0600	Peru, R Victoria	6020do 9720do
0500 0600	Peru, R Vision	4790do
0500 0600	Spain, R Exterior de Espana	3350ca 5965sa
	6055na 9630na	11890me 12035eu
0500 0600 DRM	Spain, R Exterior de Espana	9780eu
0500 0600 twhf	USA, BBG/R Marti	6030ca 7405ca
0500 0600	USA, WEWN/EWTN Irontdale AL	7555ca
	11870sa	
0530 0600	Iran, VO Islamic Rep of Iran	15530eu 17530sa
0530 0600	USA, WRMI/R Prague relay	9955ca

0600 UTC - 2AM EDT / 1AM CDT / 11PM PDT

0600 0625	Colombia, Salem Stereo	14950do
-----------	------------------------	---------

0600 0627	Iran, VO Islamic Rep of Iran	15530eu 17530sa
0600 0700	China, China R International	17680eu
0600 0700	Colombia, La Voz de tu Conciencia	6010do
0600 0700	Colombia, R Alcaravan	5910do
0600 0700	Cuba, R Rebelde 5025na	
0600 0700	Eqt Guinea, R Nacional/Bata	5005do
0600 0700	Eqt Guinea, R Nacional/Malabo	6250do
0600 0700	Mexico, R Educacion	6185do
0600 0700	Mexico, R Mil Onda Corta	6010do
0600 0700	Mexico, R Transcontinental de America	4800do
0600 0700	Peru, R Tawantinsuyo	6174do
0600 0700	Peru, R Union	6115do
0600 0700	Peru, R Victoria	6020do 9720do
0600 0700	Peru, R Vision	4790do
0600 0700	South Korea, KBS World R	6045eu
0600 0700	Spain, R Exterior de Espana	5965sa 11890me
	12035eu	
0600 0700 DRM	Spain, R Exterior de Espana	9780eu
0600 0700	Taiwan, R Taiwan Intl	7570ca
0600 0700 twhf	USA, BBG/R Marti	6030ca 7405ca
0600 0700	USA, WEWN/EWTN Irontdale AL	7555ca
	11870sa	
0605 0620 Sun	USA, FBN/WTJC Newport NC	9370na

0700 UTC - 3AM EDT / 2AM CDT / 12AM PDT

0700 0800	China, China R International	17680eu
0700 0800	Colombia, La Voz de tu Conciencia	6010do
0700 0800	Colombia, R Alcaravan	5910do
0700 0800	Cuba, R Rebelde 5025na	
0700 0800 Sun	Ecuador, HCJB/LV de los Andes	3995eu
0700 0800	Eqt Guinea, R Nacional/Bata	5005do
0700 0800	Eqt Guinea, R Nacional/Malabo	6250do
0700 0800	Mexico, R Mil Onda Corta	6010do
0700 0800	Mexico, R Transcontinental de America	4800do
0700 0800	Peru, R Tawantinsuyo	6174do
0700 0800	Peru, R Union	6115do
0700 0800	Peru, R Victoria	6020do 9720do
0700 0800	Peru, R Vision	4790do
0700 0800	Spain, R Exterior de Espana	5965sa 12035eu
0700 0800 DRM	Spain, R Exterior de Espana	9780eu
0700 0800 twhf	USA, BBG/R Marti	5980ca 6030ca
0700 0800	USA, WEWN/EWTN Irontdale AL	7555ca
	11870sa	

0800 UTC - 4AM EDT / 3AM CDT / 1AM PDT

0800 0900 fa	Bolivia, R Fides	6155do
0800 0900	Colombia, La Voz de tu Conciencia	6010do
0800 0900	Colombia, R Alcaravan	5910do
0800 0900	Cuba, R Rebelde 5025na	
0800 0900	Eqt Guinea, R Nacional/Bata	5005do
0800 0900	Eqt Guinea, R Nacional/Malabo	6250do
0800 0900	Mexico, R Mil Onda Corta	6010do
0800 0900	Mexico, R Transcontinental de America	4800do
0800 0900	Peru, R JPI del Peru	3355do
0800 0900	Peru, R Tawantinsuyo	6174do
0800 0900	Peru, R Union	6115do
0800 0900	Peru, R Victoria	6020do 9720do
0800 0900	Peru, R Vision	4790do

0800 0900 Spain, R Exterior de Espana 12035eu
 0800 0900 DRM Spain, R Exterior de Espana 9780eu
 0800 0900 twhfas USA, BBG/R Marti 5980ca 6030ca
 0800 0900 USA, WEWN/EWTN Irontdale AL 7555ca
 11870sa
 0830 0900 USA, WRMI/R Prague relay 9955ca

0900 UTC - 5AM EDT / 4AM CDT / 2AM PDT

0900 1000 Bolivia, R Fides 6155do
 0900 1000 Bolivia, R Logos 4865do
 0900 1000 Bolivia, R Mosoj Chaski 3310do
 0900 1000 Bolivia, R Santa Ana 4451do
 0900 1000 Colombia, La Voz de tu Conciencia 6010do
 0900 1000 Colombia, R Alcaravan 5910do
 0900 1000 Cuba, R Rebelde 5025na
 0900 1000 Dominican Rep, R Amanecer Intl 6025do
 0900 1000 Ecuador, La Voz del Napo 3280do
 0900 1000 Ecuador, R Quito 4919do
 0900 1000 Eqt Guinea, R Nacional/Bata 5005do
 0900 1000 Eqt Guinea, R Nacional/Malabo 6250do
 0900 1000 Mexico, R Mil Onda Corta 6010do
 0900 1000 Mexico, R Transcontinental de America 4800do
 0900 1000 Peru, R Andina 4995do
 0900 1000 Peru, R JPI del Peru 3355do
 0900 1000 Peru, R Manantial 4987do
 0900 1000 Peru, R Municipal 3173do
 0900 1000 Peru, R Tawantinsuyo 6174do
 0900 1000 Peru, R Union 6115do
 0900 1000 Peru, R Victoria 6020do 9720do
 0900 1000 Peru, R Vision 4790do
 0900 1000 Spain, R Exterior de Espana 15585eu 21540af
 0900 1000 twhfas USA, BBG/R Marti 6030ca 9805ca
 0900 1000 USA, WEWN/EWTN Irontdale AL 7555ca
 11870sa
 0930 1000 Bolivia, R Illimani/R Patria Nueva 6025do
 0930 1000 Bolivia, R Panamericana 5765do 6105do
 0930 1000 Bolivia, R Virgen de los Remedios 4111do
 0930 1000 Bolivia, Yatun Ayllu Yura/R Yura 4717do
 4715al
 0930 1000 Japan, R Japan NHK World 6195sa
 0930 1000 Peru, R Cusco 4780do
 0930 1000 mtwhfa USA, WRMI/R Slovakia Intl relay 9955ca
 0945 1000 Bolivia, R Pio XII 5952do 5955al

1000 UTC - 6AM EDT / 5AM CDT / 3AM PDT

1000 1100 Bolivia, R Eco 4409do
 1000 1100 Bolivia, R Em Camargo 3390do
 1000 1100 Bolivia, R Fides 6155do
 1000 1100 Bolivia, R Illimani/R Patria Nueva 6025do
 1000 1100 Bolivia, R Lipez 4796do
 1000 1100 Bolivia, R Logos 4865do 6165do
 1000 1100 Bolivia, R Mosoj Chaski 3310do
 1000 1100 Bolivia, R Panamericana 5765do 6105do
 1000 1100 Bolivia, R Pio XII 5952do 5955al
 1000 1100 Bolivia, R Santa Ana 4451do
 1000 1100 Bolivia, R Tacana 4782do
 1000 1100 Bolivia, R Virgen de los Remedios 4111do
 1000 1100 Bolivia, Yatun Ayllu Yura/R Yura 4717do
 4715al
 1000 1100 Colombia, La Voz de tu Conciencia 6010do
 1000 1100 Colombia, La Voz del Guaviare 6035do
 1000 1100 Colombia, R Alcaravan 5910do
 1000 1100 Cuba, R Rebelde 5025na
 1000 1100 Dominican Rep, R Amanecer Intl 6025do
 1000 1100 Ecuador, La Voz del Napo 3280do
 1000 1100 Ecuador, R El Buen Pastor 4815do
 1000 1100 Ecuador, R Quito 4919do
 1000 1100 Eqt Guinea, R Nacional/Bata 5005do
 1000 1100 Eqt Guinea, R Nacional/Malabo 6250do
 1000 1100 Mexico, R Mil Onda Corta 6010do
 1000 1100 Mexico, R Transcontinental de America 4800do
 1000 1100 Peru, La Voz de la Selva 4824do
 1000 1100 Peru, R Altura 5014do
 1000 1100 Peru, R Ancash 4990do 4992al

1000 1100 Peru, R Andina 4995do
 1000 1100 Peru, R Cultural Amauta 4955do
 1000 1100 Peru, R Cusco 4780do
 1000 1100 Peru, R Genesis 4850do
 1000 1100 Peru, R JPI del Peru 3355do
 1000 1100 Peru, R Libertad de Junin 5039do
 1000 1100 Peru, R Madre de Dios 4950do
 1000 1100 Peru, R Manantial 4987do
 1000 1100 Peru, R Melodia 5939do
 1000 1100 Peru, R Municipal 3173do
 1000 1100 Peru, R Ondas del Sur Oriente 5120do
 1000 1100 Peru, R Quillabamba 5025do
 1000 1100 Peru, R Reina de la Selva 5487do
 1000 1100 Peru, R Santa Rosa 6047do
 1000 1100 Peru, R Tawantinsuyo 6174do
 1000 1100 Peru, R Union 6115do
 1000 1100 Peru, R Victoria 6020do 9720do
 1000 1100 Peru, R Virgen del Carmen 4887do 4895al
 1000 1100 Peru, R Vision 4790do
 1000 1100 Spain, R Exterior de Espana 15585eu 21540af
 1000 1100 USA, BBG/R Marti 6030ca 9805ca
 1000 1100 USA, WEWN/EWTN Irontdale AL 7555ca
 12050sa
 1030 1100 Bolivia, R Cultural Juan XXIII 6054do
 1030 1100 Bolivia, R San Miguel 4699do
 1030 1100 Peru, Ondas del Huallaga 3330do
 1030 1100 Peru, R Sicuani 4826do
 1045 1100 Peru, La Voz de las Huarinjas 5059do
 1045 1100 Peru, R Bethel 5921do

1100 UTC - 7AM EDT / 6AM CDT / 4AM PDT

1100 1115 Ecuador, La Voz del Napo 3280do
 1100 1200 Bolivia, R Cultural Juan XXIII 6054do
 1100 1200 Bolivia, R Eco 4409do
 1100 1200 Bolivia, R Em Camargo 3390do
 1100 1200 Bolivia, R Fides 6155do
 1100 1200 Bolivia, R Illimani/R Patria Nueva 6025do
 1100 1200 Bolivia, R Lipez 4796do
 1100 1200 Bolivia, R Logos 4865do 6165do
 1100 1200 Bolivia, R Mosoj Chaski 3310do
 1100 1200 Bolivia, R Panamericana 5765do 6105do
 1100 1200 Bolivia, R Pio XII 5952do 5955al
 1100 1200 Bolivia, R San Jose 5580do
 1100 1200 Bolivia, R San Miguel 4699do
 1100 1200 Bolivia, R Santa Ana 4451do
 1100 1200 Bolivia, R Santa Cruz 6135do
 1100 1200 Bolivia, R Tacana 4782do
 1100 1200 Bolivia, R Virgen de los Remedios 4111do
 1100 1200 Bolivia, Yatun Ayllu Yura/R Yura 4717do
 4715al
 1100 1200 Colombia, La Voz de tu Conciencia 6010do
 1100 1200 Colombia, La Voz del Guaviare 6035do
 1100 1200 Colombia, R Alcaravan 5910do
 1100 1200 Cuba, R Havana Cuba 6150am 9540ca
 9550na 9850na 11690ca 11760na
 11860na 15230sa 17730sa 17580sa
 1100 1200 Cuba, R Rebelde 5025na
 1100 1200 mtwhf Ecuador, HCJB/LV de los Andes 6050sa
 1100 1200 Ecuador, R El Buen Pastor 4815do
 1100 1200 Ecuador, R Quito 4919do
 1100 1200 Eqt Guinea, R Nacional/Bata 5005do
 1100 1200 Eqt Guinea, R Nacional/Malabo 6250do
 1100 1200 Honduras, HRMI/ R Misiones Intl 3340do
 1100 1200 Honduras, R Luz y Vida 3250do
 1100 1200 Mexico, R Mil Onda Corta 6010do
 1100 1200 Mexico, R Transcontinental de America 4800do
 1100 1200 mtwhf Netherlands, R Netherlands Worldwide 9895ca
 1100 1200 Peru, La Voz de la Selva 4824do
 1100 1200 Peru, La Voz de las Huarinjas 5059do
 1100 1200 Peru, Ondas del Huallaga 3330do
 1100 1200 Peru, R Ancash 4990do 4992al
 1100 1200 Peru, R Andina 4995do
 1100 1200 Peru, R Bethel 5921do
 1100 1200 Peru, R Cultural Amauta 4955do

1100	1200	Peru, R Cusco	4780do	
1100	1200	Peru, R Genesis	4850do	
1100	1200	Peru, R Horizonte	5020do	
1100	1200	Peru, R Huanta 2000	4747do	4755al
1100	1200	Peru, R JPJ del Peru	3355do	
1100	1200	Peru, R Libertad de Junin	5039do	
1100	1200	Peru, R Madre de Dios	4950do	
1100	1200	Peru, R Manantial	4987do	
1100	1200	Peru, R Maranon	4835do	
1100	1200	Peru, R Ondas del Sur Oriente		5120do
1100	1200	Peru, R Quillabamba	5025do	
1100	1200	Peru, R Reina de la Selva	5487do	
1100	1200	Peru, R Santa Rosa	6047do	
1100	1200	Peru, R Sicuani	4826do	
1100	1200	Peru, R Tarma	4775do	
1100	1200	Peru, R Tawantinsuyo		6174do
1100	1200	Peru, R Union	6115do	
1100	1200	Peru, R Victoria	6020do	9720do
1100	1200	Peru, R Virgen del Carmen	4887do	4895al
1100	1200	Peru, R Vision	4790do	
1100	1200	South Korea, KBS World R	11795sa	
1100	1200	Spain, R Exterior de Espana	15585eu	21540af 21610me
1100	1200	Uruguay, R Sarandi	6044do	
1100	1200	USA, BBG/R Marti	6030ca	9805ca
1100	1200	USA, WEWN/EWTN Irontdale AL	7555ca	12050sa
1130	1200	Ecuador, HCJB/LV de los Andes	6050sa	
1157	1200	Colombia, Salem Stereo	14950do	

1200 UTC - 8AM EDT / 7AM CDT / 5AM PDT

1200	1245	Colombia, Salem Stereo	14950do	
1200	1258	Clandestine, VO Resistence	6070sa	
1200	1300	Argentina, RAE	11710am	mtwhf
1200	1300	Bolivia, R Cultural Juan XXIII	6054do	
1200	1300	Bolivia, R Eco	4409do	
1200	1300	Bolivia, R Em Camargo	3390do	
1200	1300	Bolivia, R Fides	6155do	
1200	1300	Bolivia, R Illimani/R Patria Nueva		6025do
1200	1300	Bolivia, R Lipetz	4796do	
1200	1300	Bolivia, R Logos	4865do	6165do
1200	1300	Bolivia, R Mosoj Chaski	3310do	
1200	1300	Bolivia, R Panamericana	5765do	6105do
1200	1300	Bolivia, R Pio XII	5952do	5955al
1200	1300	Bolivia, R San Jose	5580do	
1200	1300	Bolivia, R San Miguel	4699do	
1200	1300	Bolivia, R Santa Ana	4451do	
1200	1300	Bolivia, R Santa Cruz	6135do	
1200	1300	Bolivia, R Tacana	4782do	
1200	1300	Colombia, La Voz de tu Conciencia		6010do
1200	1300	Colombia, La Voz del Guaviare		6035do
1200	1300	Colombia, R Alcaravan	5910do	
1200	1300	Cuba, R Havana Cuba	6150am	9540ca 9550na 9850na 11690ca 11760na 11860na 15230sa 17730sa 17580sa
1200	1300	Cuba, R Rebelde	5025na	
1200	1300	Dominican Rep, R Amanecer Intl		6025do
1200	1300	Ecuador, HCJB/LV de los Andes		6050sa
1200	1300	Ecuador, R El Buen Pastor	4815do	
1200	1300	Eqt Guinea, R Nacional/Bata		5005do
1200	1300	Eqt Guinea, R Nacional/Malabo		6250do
1200	1300	Honduras, HRMI/ R Misiones Intl		3340do
1200	1300	Honduras, R Luz y Vida	3250do	
1200	1300	Mexico, R Mil Onda Corta	6010do	
1200	1300	Mexico, R Transcontinental de America		4800do
1200	1300	Peru, La Voz de la Selva	4824do	
1200	1300	Peru, La Voz de las Huarinjas		5059do
1200	1300	Peru, Ondas del Huallaga	3330do	
1200	1300	Peru, R Bethel	5921do	
1200	1300	Peru, R Cultural Amauta	4955do	
1200	1300	Peru, R Cusco	4780do	
1200	1300	Peru, R Horizonte	5020do	
1200	1300	Peru, R Huanta 2000	4747do	4755al
1200	1300	Peru, R JPJ del Peru	3355do	
1200	1300	Peru, R Libertad de Junin	5039do	

1200	1300	Peru, R Madre de Dios	4950do	
1200	1300	Peru, R Manantial	4987do	
1200	1300	Peru, R Maranon	4835do	
1200	1300	Peru, R Ondas del Sur Oriente		5120do
1200	1300	Peru, R Quillabamba	5025do	
1200	1300	Peru, R Santa Rosa	6047do	
1200	1300	Peru, R Sicuani	4826do	
1200	1300	Peru, R Tarma	4775do	
1200	1300	Peru, R Tawantinsuyo		6174do
1200	1300	Peru, R Union	6115do	
1200	1300	Peru, R Victoria	6020do	9720do
1200	1300	Peru, R Vision	4790do	
1200	1300	Spain, R Exterior de Espana	5970ca	11815sa 11880na
1200	1300	Spain, R Exterior de Espana	11910as	15585eu 21540af 21610me
1200	1300	Spain, R Exterior de Espana	13720eu	DRM
1200	1300	Uruguay, LV de Artigas	6076do	
1200	1300	USA, BBG/R Marti	6030ca	7405ca 9805ca
1200	1300	USA, BBG/Voice of America		9885ca 13750sa 15590sa
1200	1300	USA, WEWN/EWTN Irontdale AL		7555ca 12050sa

1300 UTC - 9AM EDT / 8AM CDT / 6AM PDT

1300	1400	Argentina, RAE	11710am	mtwhf
1300	1400	Bolivia, R Cultural Juan XXIII	6054do	
1300	1400	Bolivia, R Eco	4409do	
1300	1400	Bolivia, R Fides	6155do	
1300	1400	Bolivia, R Illimani/R Patria Nueva		6025do
1300	1400	Bolivia, R Lipetz	4796do	
1300	1400	Bolivia, R Logos	4865do	6165do
1300	1400	Bolivia, R Pio XII	5952do	5955al
1300	1400	Bolivia, R Pio XII	5952do	5955al
1300	1400	Bolivia, R San Jose	5580do	
1300	1400	Bolivia, R San Miguel	4699do	
1300	1400	Bolivia, R Santa Ana	4451do	
1300	1400	Bolivia, R Santa Cruz	6135do	
1300	1400	Bolivia, R Tacana	4782do	
1300	1400	Colombia, La Voz de tu Conciencia		6010do
1300	1400	Colombia, La Voz del Guaviare		6035do
1300	1400	Colombia, R Alcaravan	5910do	
1300	1400	Cuba, R Havana Cuba	6150am	9540ca 11750ca 11760am 11860na 11690ca 13780na 15230sa 15380na 17730sa 17580sa
1300	1400	Cuba, R Rebelde	5025na	
1300	1400	Dominican Rep, R Amanecer Intl		6025do
1300	1400	Ecuador, HCJB/LV de los Andes		6050sa
1300	1400	Ecuador, La Voz del Napo	3280do	
1300	1400	Ecuador, R El Buen Pastor	4815do	
1300	1400	Eqt Guinea, R Nacional/Bata		5005do
1300	1400	Eqt Guinea, R Nacional/Malabo		6250do
1300	1400	Honduras, HRMI/ R Misiones Intl		3340do
1300	1400	Honduras, R Luz y Vida	3250do	
1300	1400	Mexico, R Mil Onda Corta	6010do	
1300	1400	Mexico, R Transcontinental de America		4800do
1300	1400	Mexico, R Universidad	6045do	
1300	1400	Peru, Ondas del Huallaga	3330do	
1300	1400	Peru, R Bethel	5921do	
1300	1400	Peru, R Cultural Amauta	4955do	
1300	1400	Peru, R Cusco	4780do	
1300	1400	Peru, R Horizonte	5020do	
1300	1400	Peru, R Huanta 2000	4747do	4755al
1300	1400	Peru, R Libertad de Junin	5039do	
1300	1400	Peru, R Madre de Dios	4950do	
1300	1400	Peru, R Manantial	4987do	
1300	1400	Peru, R Maranon	4835do	
1300	1400	Peru, R Ondas del Sur Oriente		5120do
1300	1400	Peru, R Quillabamba	5025do	
1300	1400	Peru, R Santa Rosa	6047do	
1300	1400	Peru, R Sicuani	4826do	
1300	1400	Peru, R Tarma	4775do	
1300	1400	Peru, R Tawantinsuyo		6174do
1300	1400	Peru, R Union	6115do	

1300 1400	Peru, R Victoria	6020do	9720do	
1300 1400	Peru, R Vision	4790do		
1300 1400	Spain, R Exterior de Espana	11910as	15585eu	
	21540af	21610me		
1300 1400 mtwhf	Spain, R Exterior de Espana	17595na		
1300 1400 smtwhf	Spain, R Exterior de Espana	5970ca	11815sa	
	11880na			
1300 1400 DRM	Spain, R Exterior de Espana	13720eu		
1300 1400	USA, BBG/R Marti	7405ca	11845ca	
	13820ca			
1300 1400	USA, WEWN/EWTN Irondale AL		11550ca	
	12050sa			
1330 1400 whf	USA, WRMI/R Slovakia Intl relay		9955ca	

1400 UTC - 10AM EDT / 9AM CDT / 7AM PDT

1400 1430	Serbia, International R Serbia		9635eu	
1400 1500	Bolivia, R Cultural Juan XXIII	6054do		
1400 1500	Bolivia, R Eco	4409do		
1400 1500	Bolivia, R Fides	6155do		
1400 1500	Bolivia, R Illimani/R Patria Nueva		6025do	
1400 1500	Bolivia, R Lipez	4796do		
1400 1500	Bolivia, R Logos	4865do	6165do	
1400 1500	Bolivia, R San Jose		5580do	
1400 1500	Bolivia, R San Miguel		4699do	
1400 1500	Bolivia, R Santa Ana		4451do	
1400 1500	Bolivia, R Santa Cruz		6135do	
1400 1500	Bolivia, R Tacana	4782do		
1400 1500	Colombia, La Voz de tu Conciencia		6010do	
1400 1500	Colombia, La Voz del Guaviare		6035do	
1400 1500	Colombia, R Alcaravan	5910do		
1400 1500	Cuba, R Havana Cuba	6150am	9540ca	
	11750ca	11760am	13780na	15230sa
	15340na	17730sa	17580sa	
1400 1500 Sun	Cuba, R Havana Cuba	11690ca	13680ca	
	15340na	17590sa	17750sa	
1400 1500	Cuba, R Rebelde	5025na		
1400 1500 mtwhf	Dominican Rep, R Amanecer Intl		6025do	
	Ecuador, HCJB/LV de los Andes		6050sa	
1400 1500	Ecuador, R El Buen Pastor	4815do		
1400 1500	Eqt Guinea, R Nacional/Bata		5005do	
1400 1500	Eqt Guinea, R Nacional/Malabo		6250do	
1400 1500	Honduras, HRMI/ R Misiones Intl		3340do	
1400 1500	Honduras, R Luz y Vida	3250do		
1400 1500	Mexico, R Mil Onda Corta	6010do		
1400 1500	Mexico, R Transcontinental de America	4800do		
1400 1500	Mexico, R Universidad	6045do		
1400 1500	Peru, La Voz de las Huarinjas		5059do	
1400 1500	Peru, R Bethel	5921do		
1400 1500	Peru, R Cusco	4780do		
1400 1500	Peru, R del Pacifico		4975do	9675do
1400 1500	Peru, R Horizonte	5020do		
1400 1500	Peru, R Huanta 2000		4747do	4755al
1400 1500	Peru, R Madre de Dios		4950do	
1400 1500	Peru, R Manantial		4987do	
1400 1500	Peru, R Maranon	4835do		
1400 1500	Peru, R Ondas del Sur Oriente		5120do	
1400 1500	Peru, R Quillabamba	5025do		
1400 1500	Peru, R Santa Rosa	6047do		
1400 1500	Peru, R Sicuani	4826do		
1400 1500	Peru, R Tarma	4775do		
1400 1500	Peru, R Tawantinsuyo		6174do	
1400 1500	Peru, R Union	6115do		
1400 1500	Peru, R Victoria	6020do	9720do	
1400 1500	Peru, R Vision	4790do		
1400 1500 mtwhf	Spain, R Exterior de Espana	17595na		
1400 1500 smtwhf	Spain, R Exterior de Espana	5970ca	11815sa	
	11880na	21540af		
1400 1500 Sun	Spain, R Exterior de Espana	17715sa		
1400 1500 Sat/Sun	Spain, R Exterior de Espana	17755af		
1400 1500	Spain, R Exterior de Espana	15585eu	21610me	
1400 1500	USA, BBG/R Marti	11845ca	11930ca	
	13820ca			
1400 1500	USA, KJES Vado NM		11715na	
1400 1500	USA, WEWN/EWTN Irondale AL		11550ca	
	12050sa			

1500 UTC - 11AM EDT / 10AM CDT / 8AM PDT

1500 1600	Bolivia, R Cultural Juan XXIII	6054do		
1500 1600	Bolivia, R Eco	4409do		
1500 1600	Bolivia, R Fides	6155do		
1500 1600	Bolivia, R Illimani/R Patria Nueva		6025do	
1500 1600	Bolivia, R Lipez	4796do		
1500 1600	Bolivia, R Logos	4865do	6165do	
1500 1600	Bolivia, R San Jose		5580do	
1500 1600	Bolivia, R San Miguel		4699do	
1500 1600	Bolivia, R Santa Ana		4451do	
1500 1600	Bolivia, R Santa Cruz		6135do	
1500 1600	Bolivia, R Tacana	4782do		
1500 1600	Colombia, La Voz de tu Conciencia		6010do	
1500 1600	Colombia, La Voz del Guaviare		6035do	
1500 1600	Colombia, R Alcaravan	5910do		
1500 1600	Colombia, Salem Stereo		14950do	
1500 1600 Sun	Cuba, R Havana Cuba	11690ca	13680ca	
	15340na	17590sa	17750sa	
1500 1600	Cuba, R Rebelde	5025na		
1500 1600	Dominican Rep, R Amanecer Intl		6025do	
1500 1600	Ecuador, R El Buen Pastor	4815do		
1500 1600	Eqt Guinea, R Nacional/Bata		5005do	
1500 1600	Eqt Guinea, R Nacional/Malabo		6250do	
1500 1600	Honduras, HRMI/ R Misiones Intl		3340do	
1500 1600	Honduras, R Luz y Vida	3250do		
1500 1600	Mexico, R Mil Onda Corta	6010do		
1500 1600	Mexico, R Transcontinental de America	4800do		
1500 1600	Mexico, R Universidad	6045do		
1500 1600	Peru, La Voz de las Huarinjas		5059do	
1500 1600	Peru, Ondas del Huallaga		3330do	
1500 1600	Peru, R Bethel	5921do		
1500 1600	Peru, R Cusco	4780do		
1500 1600	Peru, R del Pacifico		4975do	9675do
1500 1600	Peru, R Horizonte	5020do		
1500 1600	Peru, R Huanta 2000		4747do	4755al
1500 1600	Peru, R Madre de Dios		4950do	
1500 1600	Peru, R Manantial		4987do	
1500 1600	Peru, R Maranon	4835do		
1500 1600	Peru, R Ondas del Sur Oriente		5120do	
1500 1600	Peru, R Quillabamba	5025do		
1500 1600	Peru, R Santa Rosa	6047do		
1500 1600	Peru, R Sicuani	4826do		
1500 1600	Peru, R Tarma	4775do		
1500 1600	Peru, R Tawantinsuyo		6174do	
1500 1600	Peru, R Union	6115do		
1500 1600	Peru, R Victoria	6020do	9720do	
1500 1600	Peru, R Vision	4790do		
1500 1600 mtwhf	Spain, R Exterior de Espana	15585eu	21610me	
1500 1600 Sat	Spain, R Exterior de Espana	15385af	17715sa	
1500 1600 Sun	Spain, R Exterior de Espana	9765ca	11815sa	17715sa
	17850na			
1500 1600 Sat/Sun	Spain, R Exterior de Espana	17755af		
1500 1600	USA, BBG/R Marti	11845ca	11930ca	
	13820ca			
1500 1600	USA, WEWN/EWTN Irondale AL		11550ca	
	12050sa			

1600 UTC - 12PM EDT / 11AM CDT / 9AM PDT

1600 1700	Bolivia, R Cultural Juan XXIII	6054do		
1600 1700	Bolivia, R Eco	4409do		
1600 1700	Bolivia, R Fides	6155do		
1600 1700	Bolivia, R Illimani/R Patria Nueva		6025do	
1600 1700	Bolivia, R Lipez	4796do		
1600 1700	Bolivia, R Logos	4865do	6165do	
1600 1700	Bolivia, R San Jose		5580do	
1600 1700	Bolivia, R San Miguel		4699do	
1600 1700	Bolivia, R Santa Ana		4451do	
1600 1700	Bolivia, R Santa Cruz		6135do	
1600 1700	Bolivia, R Tacana	4782do		
1600 1700	Colombia, La Voz de tu Conciencia		6010do	
1600 1700	Colombia, La Voz del Guaviare		6035do	
1600 1700	Colombia, R Alcaravan	5910do		
1600 1700	Colombia, Salem Stereo		14950do	

1600 1700 Sun	Cuba, R Havana Cuba	11690ca	13680ca
	15340na	17590sa	17750sa
1600 1700	Cuba, R Rebelde 5025na		
1600 1700	Dominican Rep, R Amanecer Intl	6025do	
1600 1700	Eqt Guinea, R Nacional/Bata	5005do	
1600 1700	Eqt Guinea, R Nacional/Malabo	6250do	
1600 1700	Honduras, HRMI/ R Misiones Intl	3340do	
1600 1700	Mexico, R Mil Onda Corta	6010do	
1600 1700	Mexico, R Transcontinental de America	4800do	
1600 1700	Mexico, R Universidad	6045do	
1600 1700	Peru, La Voz de las Huarinjas	5059do	
1600 1700	Peru, Ondas del Huallaga	3330do	
1600 1700	Peru, R Bethel	5921do	
1600 1700	Peru, R Cusco	4780do	
1600 1700	Peru, R del Pacifico	4975do	9675do
1600 1700	Peru, R Horizonte5020do		
1600 1700	Peru, R Huanta 2000	4747do	4755al
1600 1700	Peru, R Madre de Dios	4950do	
1600 1700	Peru, R Manantial	4987do	

1600 1700	Peru, R Maranon	4835do	
1600 1700	Peru, R Ondas del Sur Oriente		5120do
1600 1700	Peru, R Quillabamba	5025do	
1600 1700	Peru, R Santa Rosa	6047do	
1600 1700	Peru, R Sicuani	4826do	
1600 1700	Peru, R Tarma	4775do	
1600 1700	Peru, R Tawantinsuyo		6174do
1600 1700	Peru, R Union	6115do	
1600 1700	Peru, R Victoria	6020do	9720do
1600 1700	Peru, R Vision	4790do	
1600 1700 mtwhf	Spain, R Exterior de Espana	15385af	17715sa
1600 1700	Spain, R Exterior de Espana	15585eu	21610me
1600 1700 Sat	Spain, R Exterior de Espana	9765ca	11815sa
1600 1700 Sun	Spain, R Exterior de Espana	11815sa	17715sa
1600 1700 Sat/Sun	Spain, R Exterior de Espana	17755af	17850na
1600 1700	USA, BBG/R Marti	11845ca	11930ca
	13820ca		
1600 1700	USA, WEWN/EWTN Irontdale AL		11550ca
	12050sa		
1630 1700	Turkey, Voice of Turkey		11930va

MT SHORTWAVE STATION RESOURCE GUIDE

Afghanistan, RTV Afghanistan.....	www.rta.org.af
Albania, R Tirana.....	http://rtsh.sil.at/
Angola, Angolan National R.....	www.rna.ao/
Anguilla, University Network.....	www.worldwideuniversitynetwork.com/
Argentina, RAE.....	www.radionacional.gov.ar
Australia, ABC NT Alice Springs.....	www.abc.net.au/radio/
Australia, ABC NT Katherine.....	www.abc.net.au/radio/
Australia, ABC NT Tennant Creek.....	www.abc.net.au/radio/
Australia, ABC/R Australia.....	www.radioaustralia.net.au
Australia, HCJB Global Australia.....	www.hcjb.org.au
Austria, AWR Europe.....	www.awr2.org
Austria, TWR Europe.....	www.twr.org
Bahrain, R Bahrain.....	www.radiobahrain.fm
Belgium, TDP Radio.....	www.airtime.be/schedule.html
Canada, Bible Voice Broadcasting.....	www.biblevoice.org/
Canada, CFRX Toronto ON.....	www.cfrb.com
Canada, CFVP Calgary AB.....	www.classiccountryam1060.com
Canada, CKZN St Johns NF.....	www.cbc.ca/listen/index.html
Canada, CKZU Vancouver BC.....	www.cbc.ca/bc
China, China R International.....	www.cri.cn
China, Haixa zhi Sheng/VO Strait.....	www.vos.com.cn
Clandestine, JSR/Shiokaze/Sea Breeze.....	www.chosa-kai.jp
Clandestine, Sudan R Service.....	www.sudanradio.org
Cuba, R Havana Cuba.....	www.radiohc.cu/
Ecuador, HCJB/LV de los Andes.....	www.radiohcjb.org
Egypt, R Cairo.....	www.ertu.org
Eqt Guinea, Pan Am BC/R Africa.....	www.radiopanam.com/
Ethiopia, R Ethiopia.....	www.erta.gov.com
Ethiopia, R Ethiopia/Natl Pgm.....	www.erta.gov.com
France, R France International.....	www.rfi.fr/
Germany, AWR Europe.....	www.awr2.org/
Germany, Deutsche Welle.....	www.dw.de
Germany, Mighty KBC Radio.....	www.kbcradio.eu/
Germany, TWR Europe.....	www.twr.org
Guam, KTWR/TWR Asia.....	http://nea.ktwr.net/
India, AIR/Aizawl.....	www.allindiaradio.org/
India, AIR/Bhopal.....	www.allindiaradio.org/
India, AIR/Chennai.....	www.allindiaradio.org/
India, AIR/Gangkok.....	www.allindiaradio.org/
India, AIR/Guwahati.....	www.allindiaradio.org/
India, AIR/Hyderabad.....	www.allindiaradio.org/
India, AIR/Imphal.....	www.allindiaradio.org/
India, AIR/Itanagar.....	www.allindiaradio.org/
India, AIR/Jaipur.....	www.allindiaradio.org/
India, AIR/Jeyapore.....	www.allindiaradio.org/
India, AIR/Kolkata.....	www.allindiaradio.org/
India, AIR/Kuresong.....	www.allindiaradio.org/
India, AIR/Lucknow.....	www.allindiaradio.org/
India, AIR/Mumbai.....	www.allindiaradio.org/
India, AIR/Port Blair/Andaman & Nicobar.....	www.allindiaradio.org/
India, AIR/Shillong.....	www.allindiaradio.org/
India, AIR/Shimla.....	www.allindiaradio.org/
India, AIR/Thiruvananthapuram.....	www.allindiaradio.org/
India, AIR/External Service.....	www.allindiaradio.org/
India, AIR/R Kashmir.....	www.allindiaradio.org/
Indonesia, AWR Asia/Pacific.....	www.awr2.org/
Indonesia, VO Indonesia.....	www.voi.co.id

Iran, VO Islamic Rep of Iran.....	www.irib.ir/English/
Israel, Kol Israel.....	www.intkolisrael.com
Italy, IRRS SW.....	www.nexus.org
Japan, R Japan NHK World.....	www.nhk.or.jp/english/
Kuwait, R Kuwait.....	www.media.gov.kw/
Mali, ORTM/R Mali.....	www.ortm.ml
Micronesia, V6MP/Cross R/Pohnpei.....	www.pmapacific.org/
Moldova, R PMR/Pridnestrovye.....	www.radiopmr.org
Nepal, R Nepal.....	www.radionepal.org/
Netherlands, XVRB Radio.....	www.twr.org
New Zealand, R New Zealand Intl.....	www.rnzi.com
Nigeria, Voice of Nigeria.....	www.voiceofnigeria.org
North Korea, Voice of Korea.....	www.vok.rep.kp
Oman, R Sultanate of Oman.....	www.oman-tv.gov.om
Pakistan, PBC/R Pakistan.....	www.radio.gov.pk
Palau, T8WH/World Harvest R.....	www.whr.org/
Philippines, R Pilipinas Overseas.....	www.pbs.gov.ph/
Poland, Polish Radio/External Svc.....	www.polskieradio.pl
Romania, R Romania Intl.....	www.rri.ro/
Russia, Voice of Russia.....	http://english.ruvr.ru/
Saudi Arabia, BSKSA/External Svc.....	www.saudiradio.net/
Serbia, International R Serbia.....	http://www.voiceofserbia.org
South Africa, AWR Africa.....	www.awr2.org/
South Africa, Channel Africa.....	www.channelafrica.org
South Africa, CVC 1 Africa R.....	www.1africa.tv
South Korea, KBS World R.....	www.worldkbs.co.kr
Spain, R Exterior de Espana.....	www.ree.rne.es/
Sri Lanka, SLBC.....	www.slbc.lk
Swaziland, TWR Africa.....	www.twrafrica.org/
Syria, R Damascus.....	www.rtv.gov.sy/
Taiwan, R Taiwan Intl.....	http://english.rti.org.tw/
Thailand, R Thailand World Svc.....	www.hsk9.org/
Turkey, Voice of Turkey.....	www.trt-world.com
Uganda, Dunamis Shortwave.....	www.biblevoice.org/stations/east-africa
UK, BBC World Service.....	www.bbc.co.uk/worldservice/
USA, Amer Forces Network/AFRTS.....	http://www.voafn.dodmedia.osd.mil/
USA, BBG/Voice of America.....	www.voanews.com
USA, BBG/Voice of America/Studio 7.....	www.voanews.com
USA, FBN/WTJC Newport NC.....	www.fbnradio.com/
USA, KNLS Anchor Point AK.....	www.knls.org/
USA, Overcomer Ministry.....	www.overcomerministry.org
USA, Pan Amer Broadcasting.....	www.radiopanam.com/
USA, WBCQ Monticello ME.....	www.wbcq.com/
USA, WEWN/EWTN Irontdale AL.....	www.ewtn.com/
USA, WHRI Cypress Creek SC.....	www.whr.org/
USA, WINB Red Lion PA.....	www.winb.com
USA, WRMI/R Prague relay.....	www.wrmi.net/
USA, WRMI/R Slovakia Intl relay.....	www.wrmi.net/
USA, WTWW Lebanon TN.....	www.wtww.us/
USA, WWCR Nashville TN.....	www.wwcr.com
USA, WWRB Manchester TN.....	www.wwrb.org/
USA, WYFR/Family R Worldwide.....	www.familyradio.com/
Vatican City State, Vatican R.....	www.vaticanradio.org/
Vietnam, VO Vietnam/Overseas Svc.....	www.vov.org.vn
Zambia, Christian Voice.....	www.voiceafrica.net
Zambia, CVC Intl/1 Africa.....	www.1africa.tv



Milcom HF Aero 'OR' Band Scan Survey

In 1992, a World Administrative Radio Conference (WARC) was conducted by the International Telecommunications Union (ITU) in Malaga, Spain. Diplomats from around the world gathered at this conference to establish rules and regulations that govern the radio frequency spectrum.

Some of you about right now are probably saying, "Hey Larry, that was quite some time ago and they hold these conferences every four years or so. What was so important about WARC-92 that we are talking about it 20 years later?"

If you are new to the world of HF utility band listening, learning about some spectrum basics will help you find some fascinating frequencies to monitor. The aeronautical frequency bands located in the HF spectrum are divided into two distinct sub-bands.

The first sub-band is the one most familiar to HF aviation buffs – the 'R' or routed frequencies. This sub-band carries communications associated with aircraft (civilian and military) that are flying on established aeronautical routes anywhere in the world.

Communications on these frequencies consist of air traffic control, weather information (VOLMET), and private airline companies traffic (LDOC). In these sub-bands you will also find the bulk of the frequencies associated with the HF DL.

High Frequency Data Link (HF DL) is an ACARS communications media used to exchange data messages between aircraft end-systems and the corresponding 15 ground-based HF DL stations. Using the unique propagation

characteristics of high-frequency radio waves, the ground stations provide data link communications to properly equipped aircraft operating anywhere in the world. The result is that pilots can always communicate with someone on the ground.

The "routed" aeronautical mobile sub-band was re-channelized to a 3-kHz spacing standard several years before the WARC-92 conference convened. The frequencies associated with these "routed" sub-bands follows: 2850-3025, 3400-3500, 4650-4700, 5450-5680, 6525-6685, 8815-8965, 10005-10100, 11275-11400, 13260-13360, and 17900-17970 kHz.

The other aeronautical mobile sub-band traditionally has been a bit more obscure to all but military monitors. Dedicated readers to the yearly Klingenfuss *Guide to Utility Station* publications will recognize the term 'OR,' which stands for off-route. Military listeners have prowled the 'OR' sub-bands for years listening to the heavy concentration of military aeronautical traffic that occurs there. The military does a lot more off-route flying than the civilian aviation population.

In one of the final acts of WARC-92, Appendix 26, the aeronautical mobile 'OR' was channelized and standardized to a frequency spacing of 3-kHz like its routed sub-band cousins. Administrations had until December 15, 1997, to implement this major frequency shift. But, in the middle of November 1994, something happened to change all that and the chaos that resulted was nothing short of breathtaking.

One source that I talked to said that NATO

and European military officials decided to implement the change three years early. The results of only one ITU region implementing the change were chaotic, forcing the rest of the world to rush to implement their changes to reduce the frequency conflicts and interference that ITU Region One caused.

By the time 1995 rolled around, the Department of Defense had finally caught up and most of the changes had been made to the channel spacing. The frequencies associated with these "off-routed" sub-bands follow:

3023 - 155	43 frequencies plus 3023 that is used for worldwide common use, not just 'OR.'
3900 - 3950	16 frequencies (yes, in the 80 meter amateur radio band in Region 2). This is an ITU Region 1 only assignment.
4700 - 4750	16 frequencies
5680 - 5730	15 frequencies plus 5680 that is used for worldwide common use, not just 'OR.'
6685 - 6765	26 frequencies
8965 - 9040	25 frequencies
11175 - 11275	33 frequencies
13200 - 13260	20 frequencies
15010 - 15100	30 frequencies
17970 - 18030	20 frequencies

Over the years in my old *MT Utility World* column and this column, I have profiled users on each of the 256 'OR' frequencies that the WARC-92 conference created. Now for the first time in several years, I will present extensive band scans for each of the 'OR' sub-bands listed above in this and future *Milcom* columns. These scans will include the DoD/Canadian military department assigned to each frequency and all the activity we have heard on each frequency worldwide.

In this issue I will take a closer look at the most popular 'OR' sub-band of the all 11175-11275 kHz in Table One. The information presented in our exclusive frequency list is based on many hours of monitoring and analyzing field monitor reports from around the world.

❖ Milair Nationwide Frequency Updates

Here are the latest milair frequency changes from the Federal Aviation Administration (FAA) and the Department of Defense (DoD). All frequencies are in MHz and mode is AM unless otherwise noted.

32.1000 Fort Rucker / Runkle Stagefield, Alabama, new FM discrete



U.S. Air Force KC-135 tankers such as this one from the 100ARW at RAF Mildenhall, England, are frequent visitors on HF Aero 'OR' frequencies. (USAF Photo)

118.600 Jacksonville, Florida, Approach/departure control (ex-118.175)
 119.525 Moody AFB, Georgia, Approach control has been deleted from service.
 119.550 South Alabama Regional, Alabama (K79J), Common Traffic Advisory Frequency (CTAF)
 119.700 Dan Jones International, Texas (T51) Approach/departure control paired with 281.400 has been deleted from service.
 120.125 Barnstable Muni-Boardman / Polando Field (Hyannis), Massachusetts (KHYA) Approach/departure control
 121.900 Southwest Florida International, Florida (KRSW) Ground control
 122.000 Terrace Airport, Canada (CYXT) CTAF
 122.300 Sandspit Airport, Canada (CYPZ) CTAF
 122.700 Burns Lake Airport, Canada (CYPZ) CTAF
 122.800 Bella Bella/Campbell Island Airport, Canada (CBBC) / Bella Coola Airport, Canada (CYBD) CTAF
 123.000 Powell River Airport, Canada (CYPW) CTAF
 123.200 Atlin Airport, Canada (CYSQ) / Carmacks Airport, Canada (CEX4) / Chapman Airport, Canada (CEZ2) / Dease Lake, Canada (CYDL) Haines Junction, Canada (CYHT) / Ross River Airport, Canada (CYDM) / Silver City Airport, Canada (CFQ5) / Stewart Airport, Canada (CZST) / Telegraph Creek Airport, Canada (CBM5) / Woodcock Airport, Canada (CBQ8) CTAF
 126.700 Puntzi Mountain Airport, Canada (CYPW) CTAF
 128.750 Southwest Florida International, Florida (KRSW) Local control (ex-121.000)
 141.100 Beale AFB, California (KBAB) Pilot-to-Dispatcher (PTD) (ex-140.875)
 142.300 JNGB McEntire, South Carolina (KMMT) Pilot-to-Dispatcher (PTD) (ex-149.625)
 281.400 Dan Jones International, Texas (T51) Approach/departure control paired with 119.700 has been deleted from service.
 308.200 NAS Jacksonville, Florida (KNIP) Departure control has been deleted from service.
 345.500 Fort Rucker/Cairns AAF, Alabama (KOZR) Toth control tower south
 360.200 MCAS New River, North Carolina (KNCA) Unicom
 377.050 NAS Jacksonville, Florida (KNIP) Approach/departure control has been deleted from service.
 379.900 NAS Jacksonville, Florida (KNIP) Departure control has been deleted from service.

And that will do it for this month. Until next time, 73 and good hunting.

TABLE 1: 11 MHZ 'OR' AERONAUTICAL SUB-BAND BAND SCAN

Note: All frequencies are in kHz and the mode is Upper Sideband (USB) unless otherwise indicated. An * indicates a frequency that is not part of the 'OR' band plan.

11175.0 USAF Assignment: One of the most listened to frequencies in the HF radio spectrum. This is the primary frequency for the Department of Defense (DoD)/Joint Chiefs of Staff (JCS) HF Global Communications System (HFGCS).
 11178.0 USAF Assignment: Dutch Navy Anti-Submarine Warfare (ASW) tactical; Norwegian Navy Air Reporting and Control Network (ARCN); New Zealand Air Force Air Operations Communication Center (AOCCAK) network; U.S. Air Force Air Mobility Command (AMC) HFGCS global discrete.
 11181.0 USAF Assignment: AMC HFGCS Global

Red - SIPRNet (Secure Internet Protocol Router Network).
 11184.0 USN Assignment: ARINC HFDL Reykjavik, Iceland, Slot 3; Belgium Air Force; U.S. Navy Atlantic/Pacific fleet ship/air operations; NAS Jacksonville, Florida, Tactical Support Center (TSC) flight following - Atlantic (Fiddle call sign).
 11184.5* Mexican Navy (Tadiran beep and USB voice)
 11185.0* Colombian Navy HF Automatic Link Establishment (ALE) network (ALE/USB)
 11186.0* Unknown station sending Stanag 4481 - NATO-75 (RTTY) 850/75 with KG-84 encryption.
 11187.0 CanForce/USN Assignment: Australian Defense Force Modernized High Frequency Communications System (MHFCS) network; Belgium Air Force; Canadian Forces (CanForce) Military Aeronautical Communications System (MACS) Search and Rescue discrete; NATO or DoD Link-11 (TADIL-A) data signal (Mil-Std-188-203-1A); U.S. Navy Atlantic/Pacific fleet ship/air operations; NAS Whidbey Island, Washington, TSC flight following - Pacific (Habitat call sign); U.S. Navy Stratcom Wing One command post - Tinker AFB, Oklahoma.
 11190.0 USN Assignment: SDJ-Stockholm, Sweden, aero common carrier; U.S. Navy Atlantic/Pacific fleet ship/air operations.
 11193.0 USN Assignment: Aeroflot Airlines Moscow, Russia, Long Distance Operational Control (LDOC); U.S. Navy Atlantic fleet ship/air operations.
 11196.0 USCG Assignment: U.S. Coast Guard air/ground communications for air stations and detachments with fixed and/or rotary wing aircraft.
 11199.0 USCG Assignment: U.S. Coast Guard air/ground communications for air stations and detachments with rotary wing aircraft.
 11200.0* South East Asian Airlines - Clark, Philippines (SeaAir call sign)
 11202.0 USCG Assignment: U.S. Coast Guard air/ground communications for air stations and detachments with fixed and/or rotary wing aircraft.
 11205.0 CanForce/USN Assignment: Australian Defense Force MHFCS HF ALE network; CanForce MACS discrete; United Kingdom Defense HF Communication Service (DHFCS) Terrestrial Air Sea. Communications (TASCOMM) voice network; Key West, Florida, Southcom Flight Monitoring Facility (FMF) (Smasher call sign); U.S. Navy Atlantic/Pacific fleet ship/air operations.
 11208.0 CanForce/USN Assignment: U.K. DHFCS TASCOMM ALE network; St. Augustine, Florida, Grumman Flight Test (Echo Base call sign); NAS Jacksonville, Florida, Tactical Support Center (TSC) flight following - Atlantic (Fiddle call sign); NAS Whidbey Island, Washington, TSC flight following - Pacific (Habitat call sign); U.S. Navy Atlantic/Pacific fleet ship/air operations.
 11209.0* Iraqi Army HF ALE command network (ALE/USB)
 11211.0 USN Assignment: Belgium Air Force; Spanish Air Force; U.S. Navy Atlantic/Pacific fleet ship/air operations.
 11213.0* U.K. Royal Air Force (RAF) secure broadcast Stanag 4481 - NATO-75 RTTY 70/75 with KG-84C encryption.
 11214.0 CanForce/USAF Assignment: CanForce MACS discrete; French Navy ARCN; U.S. Air Force Air Mobility Command (AMC) HFGCS global discrete; U.S. Air Force air defense/AWACS network.
 11217.0 CanForce/USAF Assignment: Danish Air Force HF voice network; U.K. DHFCS TASCOMM ALE network; German Air Force air transport command network; U.S. Department of Homeland Security (DHS) Shared Resources

(SHARES) ALE network; U.S. Air Force Air Mobility Command (AMC) HFGCS global discrete.
 11220.0 CanForce/USAF Assignment: U.S. Air Force Air Mobility Command (AMC) HFGCS global voice/data discrete (airborne command post data duplex frequency).
 11223.0 CanForce/USAF Assignment: U.K. DHFCS TASCOMM ALE network; U.S. Air Force Air Mobility Command (AMC) HFGCS global discrete.
 11225.0 NATO or DoD Link-11 (TADIL-A) data signal (Mil-Std-188-203-1A)
 11226.0 USAF Assignment: Japanese Defense Force voice network; U.S. Air Force AMC HFGCS Scope Command ALE HF network
 11227.2* Iran's Islamic Revolution Guards Corps - PACTOR 1/200/200 encrypted with Farsi voice traffic.
 11229.0 CanForce/USAF Assignment: German Air Force air transport command network; U.S. Air Force Air Mobility Command (AMC) HFGCS global discrete.
 11230.5* Unknown station - Tadiran HF 4 FSK Autocall/125/1200.
 11232.0 CanForce/USAF Assignment: CanForce MACS voice network; U.S. Air Force AMC HFGCS Scope Command ALE HF network.
 11235.0 CanForce/USAF Assignment: U.K. DHFCS TASCOMM discrete; Italian Air Force 46 Aerial Brigade voice network; New Zealand Air Force Air Operations Communication Center (AOCCAK) network; Spanish Air Force; U.S. Air Force Air Mobility Command (AMC) HFGCS global discrete.
 11237.0* South African Navy ZSC Silvermine - Saab Grintek MHF 50 robust MFSK-33 waveform at 54.3 Baud.
 11238.0 CanForce/USAF Assignment: U.S. Air Force Air Mobility Command (AMC) HFGCS global discrete; U.S. Air Force Mystic Star network.
 11240.0* Israeli Air Force HF ALE network.
 11241.0 USAF Assignment: U.K. DHFCS TASCOMM ALE network; U.S. Air Force Air Mobility Command (AMC) HFGCS global discrete.
 11244.0 CanForce/USAF Assignment: Danish Air Force HF voice network; U.S. Air Force Air Mobility Command (AMC) HFGCS global discrete. US Strategic Command EAM restoral frequency.
 11246.0* Israeli Air Force HF ALE network.
 11247.0 CanForce/USAF Assignment: CanForce MACS discrete; U.K. DHFCS TASCOMM voice network primary frequency; U.S. DHS Customs and Border Protection (CBP) Customs Over the Horizon Network (COTHEN); U.S. Air Force Air Mobility Command (AMC) HFGCS global discrete.
 11250.0 CanForce/USAF Assignment: CanForce MACS discrete; Italian Navy ARCN; U.S. Air Force Air Mobility Command (AMC) HFGCS global discrete.
 11253.0 USN Assignment: U.K. Royal Air Force VOLMET Swanwick (Inskip); U.S. Navy Atlantic/Pacific fleet ship/air operations.
 11256.0 USN Assignment: ETK4 - Ethiopian Airlines LDOC; U.S. Navy Atlantic fleet ship/air operations.
 11259.0 USN Assignment: U.S. Navy Atlantic/Pacific fleet ship/air operations.
 11259.0 USN Assignment: U.S. Navy Atlantic/Pacific fleet ship/air operations.
 11262.0 CanForce/USN Assignment: Spanish Air Force voice network; U.S. Navy Atlantic fleet ship/air operations.
 11265.0 CanForce/USN Assignment: CanForce MACS discrete; German Air Force air transport command network; U.S. Navy Atlantic/Pacific fleet ship/air operations.
 11268.0 USN Assignment: U.S. Navy Atlantic/Pacific fleet ship/air operations.
 11271.0 CanForce/USAF Assignment: CanForce MACS discrete.



Digital Radio in Mexico

Back in 2008, Mexico announced IBOC/HD Radio would be authorized for use by stations within 320 km (200 miles) of the U.S. border. The country's digital radio policy has changed, bringing HD to a wider swath of the country. I know DXers on both sides of the border will be concerned with this development; maybe they shouldn't be, as it doesn't appear rollout is going to happen very quickly...

Mexico's IBOC policy is similar to that in the U.S. The same iBiquity standard is mandated, for both AM and FM use. Transition to digital is voluntary, stations are not required to switch to digital. Stations wishing to go digital must obtain permission from the Comisión Federal de Telecomunicaciones (COFETEL), the government agency responsible for broadcast regulation.

Stations are required to use the hybrid mode, broadcasting the digital signal on the same channel as the analog. As in the U.S., the HD1 main channel must simulcast the station's analog signal. Unlike the FCC's policy, in Mexico, IBOC stations wishing to use HD2/HD3/HD4 subchannels must notify COFETEL at least 30 days in advance.

A list of stations authorized to use IBOC has been released. There are only 42 stations on this list, ten of them on AM. Most are in border states like Chihuahua and Baja California Norte, although there are seven Mexico City stations on the list, and a few others in the country's interior. Of the 42 authorized stations, only four were actually operating in digital as of April; two in Tijuana and two in Mexico City. All four are FM. See the sidebars for a list of those stations already operating or under construction, and of the AM stations authorized to go digital.

❖ And in the U.S....

I mentioned above that Mexican IBOC policy requires stations to operate in "hybrid mode," broadcasting digital and analog signals simultaneously on the same frequency. The same policy applies in the U.S. A second "full digital mode" is defined in the IBOC standard. This mode has no analog signal. Full digital mode would allow much better digital coverage, as the full power of the station could be devoted to the digital signal. A 5,000-watt hybrid mode AM station can use no more than 50 watts of digital power. A 5,000-watt digital-only station would have 5,000 watts of digital power.

Full digital mode would also reduce interference to adjacent stations. In hybrid mode, the digital signal must be transmitted at the edges of the channel to leave room for the analog signal. In fact, on AM the digital "spills out" into adjacent channels. In full-digital mode, it's no longer necessary to leave room for an analog signal; the digital no longer needs to "spill out".

However, that digital-only station would have no analog signal. Since few digital radios have been sold (understatement!), any digital-only station would have almost no audience. The FCC doesn't allow digital-only mode – and as you might guess, nobody has asked them to lift that ban!

A June article in *Radio World* says three broadcast groups have committed to a full-digital test. The idea is to find an existing station that isn't doing very well in the marketplace, and convert it to digital-only for testing. An underperforming station is necessary, as the test station is going to lose its entire audience! We'll keep you informed if anything happens on this front.

The following Mexican FM stations are in the process of installing IBOC/HD Radio digital equipment:

BN Tijuana	99.7	XHTY-FM*
BN Tijuana	102.5	XHUAN-FM
BN Tijuana	107.3	XHFG-FM*
CI Cd. Juarez	106.7	XHUAR-FM
DF Mexico	90.5	XHDA-FM*
DF Mexico	94.5	XHIMER-FM
DF Mexico	98.5	XHDI-FM*
DF Mexico	105.7	XHOF-FM
DF Mexico	107.9	XHIMR-FM
OX Salina Cruz	96.3	XHSCO-FM

* These four stations are already broadcasting with IBOC/HD Radio.

cover the city that the station is authorized to serve. By May 31st, each station must inform the government whether its permanent digital operation will be on its interim digital channel, or if the station will revert to its old analog channel. And by November 26th, the analog signal must be removed from the air.

Note that I didn't specify January 31st of which year. That depends on which group of cities you're talking about. Cities near the U.S. border, Mexicali, Cd. Juarez, Monterrey, etc., must convert during 2013. Another list of cities, largely in the center and east coast of Mexico, must convert during 2014. This includes Mexico City, Veracruz, and Guadalajara among many others. Finally, a third list of cities must convert during 2015. This list includes Chihuahua, Durango, and Acapulco. Tijuana is a special case; a pilot digital conversion project will remove that city's analog stations from the air on April 16th, 2013. San Diego TV DXers will probably appreciate the opportunity to log skip DX on channel 6 next year.

Some relay stations *are not required to convert*. As in Canada, some Mexican stations may continue in analog indefinitely. In Canada, many of these no-conversion-required stations are being shut down as equipment wears out. I suspect the same will happen in Mexico.

Mexican policy strongly suggests something that has been suspected but not officially stated in the U.S., that wireless mobile operators expect to receive even more ex-TV spectrum than they already have in the digital transition. Channels 52-83 have already been lost to TV. The Mexican DTV policy statement now discourages use of channels 38-51. It also discourages use of low-band VHF channels 2-6. These channels have had very poor results in the U.S. and one Canadian station on channel 6 is in the process of moving to a UHF assignment.

A few other interesting points:

- Stations are encouraged to broadcast more than one program ("subchannels").

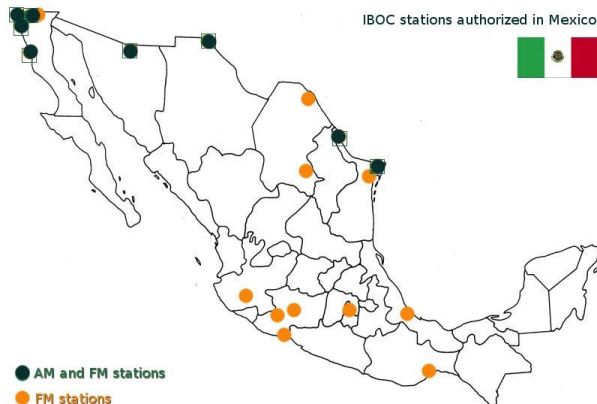

42 Mexican stations are authorized for IBOC digital broadcasts. (Courtesy: Author)

❖ How about digital TV?

Mexico's COFETEL has also amended the country's digital TV transition policy. For many of the country's TV stations, the end of 2015 is now the "drop-dead" date for analog broadcasts. There are a few interesting twists in Mexico's DTV transition, keep reading!

The country has been divided into three groups of cities. By January 31st each station in each group must begin broadcasting a digital signal strong enough to

Mexican IBOC guidelines allow the following AM stations to adopt HD:

BN Mexicali	1150	XERM
BN Rosarito	950	XEKAM
BN San Quintin	1160	XEQIN
BN Tijuana	540	XESURF
CI Cd. Juarez	1460	XEYX
SO Nogales	1370	XEHF
TM Matamoros	970	XEO
TM Nvo. Laredo	1000	XENLT
TM Rio Bravo	590	XEFD
TM Rio Bravo	1110	XEOQ

- Stations which only broadcast one program *must* broadcast that program in HD.

- Stations must inform the government if subchannels or Mobile DTV are to be used.

- Applications for *new* stations are *not* frozen. Applications for new digital stations will be accepted; applications for new *analog* stations will be accepted in areas where conversion is not required.

And maybe the most interesting, at least for us engineers, is that Mexican stations are allowed to use H.264 video encoding. Digital stations in many countries, including the U.S. and Canada, use MPEG-2 video. H.264 is a newer and more efficient system; it's being used in several European countries. Some Mexican stations have already been reported using this coding, and several ION stations in the U.S. have experimented with using H.264 to broadcast several channels of Hispanic programming.

H.264 is not compatible with existing U.S. market TV sets. However, Mexico is a large enough market for TV sets that I expect the set makers will be very willing to build receivers that support this improved coding. And once they do, those receivers will probably also be sold in the U.S.

❖ New TV Stations

You may also remember an item a couple of years ago, where a firm resurrected a long-forgotten law from the 1970s and claimed it required the FCC to allow them to move two TV stations from Wyoming and Nevada to New Jersey and Delaware. The FCC didn't buy PMCM's precise argument, but they did agree the law required them to assign VHF channels to those states. Channel 4 was assigned to Atlantic City, and channel 5 to Seaford, which, ironically, is 20 miles from Delaware's seacoast. An auction was held, and Western Pacific Broadcast LLC won both channels.

The Atlantic City station, WACP, is now on the air. A DXer in upstate New York noticed an unidentifiable digital signal on channel 4 at 7:00 on the morning of June 7th. Trip Ericson, operator of the RabbitEars.info website, was able to confirm WACP on the air around 3:30pm. Four and a half hours later, veteran TV DXer Jeff Kadet in western Illinois received the station via sporadic-E skip. I think this may set a new record for shortest time between a new station going on the air, and that station being DXed!

Call letters WMDE have been assigned to Western Pacific's Delaware station. However, as of late July this station is not yet on the air.

WACP4

A new station is on the air in Atlantic City. (Courtesy: WACP-TV)

❖ 540 & 1550 kHz

Last time I reported the CBC had asked to move their French-language station in Windsor, Ontario from its 540 kHz assignment to the 1550 kHz frequency recently abandoned by their English station. The towers at the 540 site were in bad shape; it was felt to be more economical to move to the 1550 site, rather than repairing 540. At press time, there had not yet been any action on that request.

I suggested DXers might monitor the 1550 frequency, to catch whatever might be available while the CBC transmitter is still silent. Bryan W8LN forwarded information on one station that may be DXed on 1550. WLOR Huntsville, Alabama operates on the frequency with 50,000 watts daytime and 44 watts at night. He notes the station has had problems with the automatic power switching which is not unusual. WLOR is simulcast on W251AC, 98.1FM. Programming is oldies.

Bryan says the station was once owned by the Smith family of Huntsville. At the time, the call letters were WAAY, it was co-owned with WAAY-TV 31, and was one of the most popular stations in Huntsville. The station was sold – but not the land. The Smith family still owns the property, which is now a self-storage operation.

❖ English ou Française?

The saga of 690 and 940 in Montreal continues. We've reported that English language all-sports station CKGM-990 has been granted permission to move to the 690 kHz channel. This channel had, since it first went on the air, broadcast in French. First, it operated as CBF, with the CBC's French-language service; then, as CINF, a French all-news operation. I expressed some surprise the Canadian government would allow this prime channel to switch languages.

Now, it looks like 690 may remain a French channel after all. Along with the frequency change from 990 to 690, CKGM has now requested permission to switch languages. They want to operate as "RDS Radio"; RDS (Réseau des Sports) is a French-language cable TV sports channel. At press time, the CRTC has not decided whether to grant this request.

❖ Until next time...

Have you logged any interesting DX from Mexico? Please write, at 7540 Highway 64 West, Brasstown NC 28902-0098, or by email to dougsmith@monitoringtimes.com. Good DX!

STATION REPORT

NEW STATIONS:

New stations on the air:		
Agana, Guam	1350	KUSG
	250/250 ND	
Sparks, Nevada	1060	KFOY
	10,000/250 DA-2	

Permits granted for new stations:		
Grants Pass, Oregon	830	5,000/1,000
	DA-N	

Applications for new stations:		
Sanger, California	1040	250/1,000 DA-2

St. Catharines, Ontario	1220	
	10,000/10,000	
Montreal, Quebec	600	10,000/5,000

DELETIONS:

Stations deleted:		
Beaver Dam, Kentucky	1600	WAIA
Winkler, Manitoba	1570	CKMW (going to 103.7 FM)
Yellowknife, N.W.T.	1340	CFYK (going to 98.9 FM)
Portsmouth, Ohio	1400	WPAY
Brownsville, Penna.	1130	WASP
Connellsville, Penna.	1340	WBGJ

ND: non-directional
 ND-D: non-directional, only operates daytime
 DA-N: directional at night only
 DA-D: directional during daytime only
 DA-2: directional all hours, two different patterns
 DA-3: directional day, night and critical hours, three different patterns

URLS IN THIS MONTH'S COLUMN

- <http://americanbandscan.blogspot.com> My AM DX blog
- <http://abclocal.go.com/wls/video?id=8729614&pid=null&syndicate=syndicate§ion=Video> of the removal of the old WLS-TV analog antenna
- http://cft.portaldesarrollo.com/wp-content/uploads/2012/05/TDT_rev2012_1.pdf Mexican DTV policy (in Spanish)
- <http://www.hdradio.com/mexico> iBiquity's HD Radio page for Mexico
- <http://www.radioworld.com/article/all-digital-am-tests-on-the-table/214148> Radio World item on full-digital tests
- <http://www.rabbitsinfo.com> Trip Ericson's TV station website

PERSEUS SDR Direct Sampling HF-Receiver



The **Microtelecom Perseus** is a cutting-edge, multimode, software defined receiver covering 10 kHz to 30 MHz. Enjoy world class performance: 3rd order IP: +31 dBm, Sensitivity: -131 dBm, Dynamic Range: 104 dB (BW 500 Hz CW). An impressive full span lab-grade spectrum display function is featured. An almost magical spectrum record feature allows you to record up to an 800 kHz portion of radio spectrum for later tuning and decoding. The audio source is via your PC soundcard. The Perseus operates from 5 VDC and comes with an international AC power supply, AC plug converter, SO239 to BNC RF adapter, USB cable and CD with software and detailed manual. Made in Italy. Visit www.universal-radio.com for details!



Universal Radio
 6830 Americana Pkwy.
 Reynoldsburg, OH 43068
 ♦ Orders: 800 431-3939
 ♦ Info: 614 866-4267
www.universal-radio.com



Fall Listening

It's October and the first hints of cold weather are upon us here in southern Ontario. Canadian Thanksgiving is in mid-October and it signals the end of the busy pleasure boat season. The Rideau, Trent-Severn and Ottawa River canals will close for the year and many of the lighted aids in the smaller channels will be decommissioned for the winter season. The scanner traffic now is mainly commercial shipping and is quite interesting. We have already had a tug and barge tie up in Kingston, for towing winch repairs. We had a very dry summer so low water levels contributed to some interesting traffic on VHF and some calls to the local Coast Guard base.

Water levels reached all time lows in many areas and daily water level broadcasts on VHF were followed closely. Montreal harbor was at one time one foot below chart datum. The maximum depth in the St. Lawrence Seaway for ocean vessels was reduced by 3 inches in early July. Since we travelled the Ottawa River, the low levels were of critical importance to us. Up to the minute safety information is always valuable.

I have finished my five trips as mate on the Canadian Empress, along with a few days on the Island Belle. Fortunately, while on the Empress, we met the tow of the retired Canadian submarine HMCS *Ojibwa*. She became a permanent exhibit in Port Burwell this past September. An amateur radio station was installed aboard her.

While on the *Island Belle*, I made a trip in the harbour during a reenactment of the war of 1812. There were small craft everywhere and I had 150 people on board. Just as I was maneu-

vering so my people could see the firing cannons, a personal water craft flipped beside me and the man was lying in the water. He seemed winded so I called the local Coast Guard who were nearby and sent their Zodiac to attend to the person.

All the local tour boats and the Empress are now being readied for their winter lay-up. Yes, I have done the Indianapolis 500 pit stop level maintenance on my snow blower. After last year's mild winter and little ice, I expect we will make up this snow season. My antennas have been secured as well.

No doubt we will have some weather warnings, particularly in November. Gale and storm warnings are common on the Great Lakes at this time of year. The radio can get exciting during these events.

❖ Unusual Radio Monitoring

"Pan Pan, Pan Pan. This is Prescott Coast Guard Radio with a report of a capsized pleasure craft opposite the Marine Museum in Kingston." This is not an unusual broadcast except that I was sailing in the Beauharnois Canal near Lachine Quebec, when I heard this on channel 16. It was an exceptionally hot day and we had an inversion (ducting) of VHF signals. This usually signifies a hot period or a weather disturbance. Signals from Buffalo, New York Coast Guard and Quebec Traffic Centre were also heard on VHF. I had a similar event here at home just before I wrote this column. I heard long range VHF traffic and the AIS received signals from an extended range. I did my usual check for inversions by looking at the Weather Radio channels. All seven could be heard when I usually hear only three. I was out mobile that morning and tripped a repeater in Bath, New York with 5 watts of power through my mobile antenna. I also heard RCC Trenton on channel 82A. Usually, I just hear the aircraft calling them. Those of you in warm climates should always watch for these events.



The tour boat *Jaques Cartier* leaving the *Ste. Anne de Bellevue* lock on the Ottawa River. (Courtesy: Author)

I also had an unusual event on AM radio. I accidentally tuned the radio in my car to 1710 kHz and heard a weather radio-type report giving the high and low tide. There was interference so I did not get the station call before I got home but I believe the station was in New Jersey. I plan to listen later in the year when the days are shorter and the propagation is better on that frequency.

You may hear some different signals on the Canadian amateur bands this fall. Industry Canada has made some special licenses available so that some Canadian amateurs can experiment with some specific 5 MHz frequencies, similar to those in use in the United States. 5332, 5348, 5358.5, 5373 and 5405 kHz have been listed. We may also get 5329 for domestic Canadian use. This can also be changed before all amateurs can use the band in 2013. I had planned to apply for one of these licenses and build a 5 MHz antenna. However, we may receive permission sooner than expected so I was advised to wait. Those of us who monitor frequencies like 5696 and 5717 kHz for SAR calls will have a good idea of the propagation.

❖ HF RADIO

First of all, I have a correction to my July column. The HF frequencies I reported for Rochester, New York were applied for by the fast ferry that used to run between Rochester and Toronto. However, they were never used, according to mail I have received. With the shorter days, the lower frequencies should be much more active. Hopefully our SFI will increase as well.

It is great to hear from John Musgrave



HMCS *Ojibwa*, on a floating dry-dock being towed to Port Burwell for use as a permanent display. Photo taken above the Eisenhower Lock of the Seaway from the Canadian Empress. (Courtesy: Author)



Cement carrier Stephen B. Roman rising in lock seven of the Welland Canal. She regularly loads in Picton, near Kingston and is often heard on VHF here. (Courtesy: Author)

out of Oona River, British Columbia. John has a new sailboat and travels all over the west coast. He was even involved in a rescue of three fishermen who were ashore for ten days in the wilds. John actually made the CBC national news for his involvement. He also spotted a deployed life raft and was involved in another search. Communications was with Prince Rupert Radio and satellite phone.

He also searches the coast for items and has remarked about the millions of tons of wreckage that has drifted from Japan to Canada as a result of last year's tsunami. I can just imagine the radio traffic and what is found. We have already heard about a 180 foot fishing boat and a container that held a Harley Davidson motorcycle making it all the way across the Pacific.

John's radios are powered by a 90 watt solar panel and he uses an underwater hydro plant to power the shack on shore. He reported that 5717 and 6715 kHz are active frequencies in his area. He also monitors the weather broadcast on 4426 kHz at 0607 UTC. He listens to NAVTEX on 518 kHz to several stations including Tofino, British Columbia.

The beacon ZP on 368 kHz from Sandspit would be a great catch here on the east coast. The great Northern Boater's on 3870 at 0630 and 0730 PST is worth monitoring. Cruise ship traffic in his area has been sparse over the last couple of years.

The Caribbean should be coming alive with traffic as a result of the annual migration of yachts to the south for the winter. I remind listeners of the weather broadcast from ZBR Bermuda radio on 2582 kHz at 0035 UTC and every four hours thereafter.

A good list of the Caribbean stations on the marine band and amateur radio can be found at www.docksideradio.com. For a fee, mariners can subscribe to the Caribbean Weather Center. Their broadcasts use USB and times are UTC. Listen on 4045 at 1000 and 1200, 8137 at 1100, 8104 at 1130, 12350 at 1300, 6221 at 1330 and 8104 as needed.

Do not forget Herb's South bound II weather net at 1600 UTC on 12359 USB. The Cruiseheimer's Net at 1230 UTC uses 6516 as its primary frequency, with 6224, 6227 and 6230 as secondary frequencies for the winter. I am not sure when they change from their

summer frequencies of 8152 as primary or 8146 and 8164 as secondary. The BASRA weather net gives local Bahamas weather on 4003 at 1100 UTC.

Amateur radio has some good listening from this area. The Intracoastal Waterway net is on 7268 LSB at 1145 and their CW net is on 7047 at 1115. K2PG runs his Caribbean weather net on 7086 LSB at 1130 UTC. The Mississauga Maritime Net runs on 14121 USB at 1245. This is a good spot for Canadian Listeners. The Trans Atlantic net runs on 21400 USB at 1300 and the Florida Net runs at 1400 on 7292 LSB.

Hurricane season sees the Hurricane Watch Net on 114325 USB when needed. Remember the nets on 14300 USB daily. The Intercon Net is followed by the Maritime Mobile Service Net and the Pacific Seafarers Net. The MMSN gives east coast weather information on the half hour. All have good web sites for further information. Please check the August issue of *Monitoring Times* for the information on the National Hurricane Center in Miami and their station, WX4NHC. Canadian Coast Guard radio stations on the east coast will broadcast weather warnings on 2598 or 2749 kHz USB after announcing on 2182 kHz.

www.yachtcom.info/Marinessb gives a good listing of European MF marine stations and their broadcast times. 2226 kHz USB seems to be a good frequency for the United Kingdom while 2657 is listed for Portugal and the Azores. They also list the USCG USB weather broadcast times and frequencies. I often listen to 6501 and 8764 kHz in this area.

❖ Maritime Radio Historical Society

The MRHS in Point Reyes is a group of radio enthusiasts who keep the history of marine radio alive by maintaining the station and equipment. They have recently restored a fantastic transmitter and some Marconi Atalanta receivers. Their station KSM is usually on the air from 1700 to 2300 UTC every Saturday. They transmit CW on 426, 4350.5, 6474, 8438.3, 12993, 16914 and 22445.8 kHz and RTTY on 6328, 8433 and 12631 kHz. KSM uses Baudot and FEC for its RTTY broadcasts. Baudot is a 170 cps at 45 baud and the FEC is a 170 cps shift at 100 baud. Press / weather are transmitted on CW at 1700 and RTTY at 1800 UTC.

Their CW repeated message (the wheel in radio terms) can be heard and when a ship calls them they repeat the frequency to be used so you can hear the transmissions. Look for the ships on 500, 4184, 6276, 8368, 12552, 16736, and 22280.5 kHz. Their amateur station K6KPH is also on at this time and can be contacted. QSL cards from K6KPH or KSM can be obtained by writing the MMRS.

Check out their web site at www.marineradio.org for all the information. Be

sure to sign up for their newsletter to see what Richard Dillman and the gang are up to next.

❖ Local Activity

The Frontenac County Emergency Communications Group activated the retired icebreaker Alexander Henry for field day this year. We hope that many people got to work the station from the Marine Museum of the Great Lakes. We also set up our stations at some local lighthouses and islands. Next year the local group plans more of these events. It gives us a great chance to try out our emergency antennas etc.

I am personally taking charge of an event for 2014. It was in January 1914, that VBH Kingston began as a Marconi wireless station. It was later taken over by the Canadian Government and ran until the late 1970s when it became a remote facility of VDQ Cardinal and the VBR Prescott Coast Guard Radio.

We would like to get amateurs in other communities to commemorate HF marine radio on the lakes. Some of the stations began in 1912 but all the Canadian Great Lakes stations were on the air in 1914. It would be great to celebrate 100 years of marine radio! Stations in Thunder Bay, Sault Ste. Marie, Wiarton, Sarnia, Port Burwell, Toronto and Kingston were established.

Locally, we are applying for a special call sign using VBH and permission to operate on the original site of VBH. This property is now owned by the Department of National Defense. We are also applying for permission to use some marine frequencies and even have a spark gap transmitter which can be activated.

I would also appreciate any information and pictures off VBH which people might have. I know they operated radiotelephone on 1630 and CW weather broadcasts on 187 kHz in 1936.

I was really enjoying the radio traffic on the 100th anniversary of the Titanic sinking. I worked GR100MGY, VO1MGY, ZW7MGY, W0S and K3MGY in April. I could not help but think back to that tragic day. It was this disaster which sparked the marine radio stations on the Great Lakes.



Vintage china cup from the White Star Line of which the Titanic was part. (Courtesy: Author)

And, finally, I received an email from Brian N8UV in Traverse City Michigan. He worked at NMD Cleveland Ohio in the 1950s. He remembers hearing many of the Canadian Stations on 2182 kHz AM as well as the American Great Lakes stations. Sure would like to talk to him over a cup of coffee!



“Arrrr, There be Radio in Them 0s and 1s!”

By Loyd Van Horn W4LVH

As a life-long radio hobbyist, I have dipped my toes into just about every corner of the available spectrum that I could spin a dial for. I really gravitated to amateur, mediumwave and FM radio DXing, but at various times have also tried my hand at TV DX, shortwave, long-wave, public safety, air traffic, HF utilities and even pirate radio.

With the advent of Internet radio, I was able to bring many of my interests with me to the new medium. Mediumwave and FM radio stations from around the world are at my disposal online. Shortwave radio stations are moving online en masse. There are streaming receivers that allow you to tune in HF broadcasts from listening posts around the world, and online streaming scanners let you be in the middle of the action, even if your antenna can't reach those distant signals.

But what, then, of the pirates? I have had many great discussions with my fellow DXers over the death of shortwave radio due to the number of stations “jumping ship” to the Internet and how I thought the entire idea was being greatly over-exaggerated. There was one area, though, I was certain would see its demise through the Internet: pirate radio.

With the relative ease and low cost of starting an Internet radio station compared to operating a broadcast radio station, especially when you factor in the risk of operating a “pirate” station, Internet radio just seemed to be the obvious answer for those wanting to put their own station “on-the-air.”

Well, pirate radio isn't dead yet over the airwaves; there are still stations to be found. However, here too, we are starting to see a migration to the Internet.

I recently read an article detailing the online move of former Brooklyn, New York pirate radio broadcasters, Jim Nazium and Hank Hayes. Now operating the Hank and Jim Radio Network, what began as an illegal AM radio station broadcast back in the 1970s has now gone ‘legit’ through the power of the Internet.

It made me wonder, just how many former pirate stations are going online now? Just how easy would it be to start your own Internet radio station, if you wanted to tap into that inner rebel in yourself?

To answer the first question, there are obviously people making the move and that number will increase. Now, lest you begin to think it is entirely doom and gloom,

there are pockets of resistance where the hum of a transmitter is still preferred over the whirl of a computer's cooling fan.

Another article I came across recently discussed the increase in the number of pirate radio stations available in Australia. There is somewhat of a pirate radio renaissance happening “down under.” Many of these stations are helping to feed underground music genres and reach people that probably don't have much in the way of access to Internet radio stations.

So, just as with shortwave radio, there will always be a group of people out there skirting authority to broadcast their favorite songs and viewpoints through pirate radio broadcasts. Even

though I am firmly embracing the new technology available through the Internet, there is something warmly comforting in knowing that pirate radio – in its purest form – will never really die.

❖ Embracing your Inner Pirate

For those of us that don't take the threat of the hammer of the law coming down on our heads lightly, how realistic is it to think that we could start our own Internet radio station? It is not entirely out of the question, and it may be easier than you think. Just be careful, more on that in a bit.

For most of us, the equipment and software you need to get started are probably lying around our homes already. You need a computer that can connect to the Internet that will act as the ‘transmitter’ for your online station. You will need some sort of automation system that will play your music, voice-overs of you introducing songs, station liners, etc. You will need a microphone if you plan on doing any voice-over work for your station. If you are going to be a music station, you will need songs. That can be the tricky part.

You will definitely want to make sure you are licensed to play the songs you want to play online. There are services such as Live365 that will help you do this for a monthly fee. You will definitely want to make sure you do not overlook this step, as the record industry is all too willing to pursue those who aren't paying their dues.

If you want a lesson in the tricky nature of licensing, just ask the folks at WahWah.fm. This site and smartphone app started with a pretty ingenious premise that was quickly made relatively impossible due to licensing challenges.

The premise of WahWah.fm, was that users could build their own playlists of music, which they could then “broadcast” to their friends over the Internet through the smartphone app. In this way, WahWah was really trying to help people start their own online “pirate” radio stations.

However, once the nearly constant negotiations with record labels over licensing began, the WahWah.fm founders realized they were fighting an uphill battle at trying to instigate this new business model into the industry and ultimately, had to pack it up.

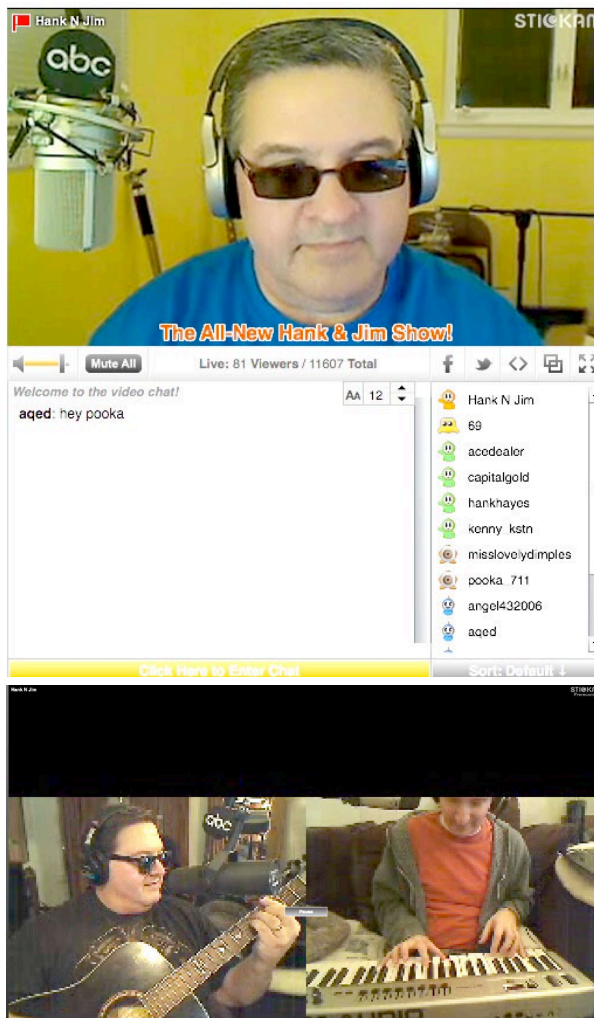

Once relegated to pirate radio, The Hank and Jim Radio Network have found a legitimate and legal home through Internet radio. (Source: Stickam.com)

Now, the particulars of starting your own station are a bit beyond the scope of this column. I have provided some links in the GlobalNet links table to help you at least get started with your research, if you are so inclined.

If you do start your own Internet radio station, give me a shout at globalnetmt@gmail.com and let me know how the process worked for you. I may just share your experience with our readers!

❖ For Those who would rather Listen

As tricky it can be to navigate the waters of starting an Internet radio station, the process by which you set up your Internet radio listening post is – thankfully – much easier.

You have a wide range of products and options at your disposal for tuning in your favorite Internet radio stations. You can go big and expensive, or cheap and small. It all depends on your budget, your needs and just how you want to listen to your Internet radio.

❖ The Dedicated WiFi Radio

This was my first entry into the Internet radio world, a radio device that is dedicated to Internet radio. I first dipped my toes in the water with my parents' bedside WiFi radio. It amazed me that I could tune in stations around the world as easily as I had stations like KMOX-AM 1120 in St. Louis when I was growing up.

Being somewhat of a gear-geek, I have now collected my fair share of WiFi radios. My main ones are a Logitech Squeezebox by the bedside, a C. Crane WiFi Radio in the home office and a Sangean WFR-1 in the living room. Each of these provides me with a different experience, and can demonstrate some of the things to consider when putting together your own arsenal of radios.

Starting with the Sangean, this is the conversation piece of the living room. The natural-wood finish and booming sound are a perfect fit for my living room. When I am entertaining guests, I simply turn on the Reciva-based radio to a station that provides good background music, and I am able to fill the room with audio, without it being overpowering or interfering with conversation. This one always gets quite a few comments and questions from visitors.

The Logitech Squeezebox is the perfect bedside radio. I am able to stream stations through the TuneIn service, set a sleep timer so that it will automatically turn off after an hour or so. The display has a large clock, so I can easily see the time, even when blearily-eyed upon first waking. Plus, the Squeezebox has a collection of "natural sounds" and the "Rain Outside" is the perfect way to drift away into a deep sleep.



Sangean WFR WiFi receiver. (Courtesy: Sangean)

The C.Crane was a perfect fit for my home office. It is small, so it doesn't take up much shelf space. This is important as I need to be able to get the most of the limited space I have available. Even sitting across the room from the radio, the volume is more than adequate for any listening I want to do. The included remote control means I can sit at my computer and control the volume without ever even having to turn around to the radio, which sits behind me.

Your needs and experience will obviously dictate which WiFi radio is a good fit for you. There are a number of different options from tabletop models like those I use, to component units that are designed for use in a home theater system, to portable units that can be taken outside or just around the house.

The number one thing to make sure you keep in mind when purchasing a WiFi radio is your WiFi signal strength. You will want to make sure you have a strong enough signal for your radio to be able to stream high quality audio without having to constantly stop for buffering.

❖ Smartphone Apps

The largest growing method people are using to access Internet radio is through their smartphone. The best part about using a smartphone to access Internet radio is the portability. I use my TuneIn or Pandora app while at work, in the car, out on a hike, anywhere I want to bring music with me. Then when I come home, my smartphone connects to my WiFi network to make sure I don't go over my allotment of data access through my cell provider.

That is a key concept to remember. Even those of us still on an "unlimited" data plan with our providers are starting to see caps in just how much data we can consume. Everyone else is on a data plan with a set limit of how much data can be used before extra fees kick-in. Before you start streaming Internet radio through your smartphone, educate yourself on just how much data usage is provided to you through your provider, an idea on how much you have been using, and what will happen should you exceed your allotment. Doing so will help reduce the risk of surprising large extra charges on your bill.

When combined with a docking station, such as those made by iHome, Bose and Sony, you can combine the portability of a smartphone with the audio quality of a dedicated WiFi radio. Some docking stations even have built in WiFi radios in them as well, giving you options in how you want to access your favorite Internet radio streams.

The future of Internet radio completely hinges on the continued growth of smartphone use. The portability of smartphones, combined with the options for home use, make them the end-all-be-all of WiFi radios.

❖ Oh Yeah, There is also Your Computer

Not to be forgotten, you can still access Internet radio directly through your computer. Both TuneIn and Reciva allow you to stream stations directly through their Web sites. Same goes for Slacker, Pandora and other Internet radio options.

With the advent of smartphones, many see streaming through a laptop or even a desktop to be a bit confining. However, combined with a decent computer audio system or some quality headphones, streaming through your computer can be an excellent option.

The bottom-line: Do your research, decide how you will be trying to access Internet radio streaming and use that to help make a decision on the best method for listening.

❖ GlobalNet Links

Former pirates move to the Internet - <http://rbr.com/former-pirates-move-to-the-internet/Wahwah.fm> killed by license costs - <http://gigaom.com/europe/learning-the-hard-way-music-service-wahwah-fm-killed-by-license-costs/>

Pirates plunder the high Cs - www.wyndhamweekly.com.au/news/national/national-general/pirates-plunder-the-high-cs/2638018.aspx?storypage=0

Starting your own Internet radio station - www.pcworld.com/article/190705/start_your_own_internet_radio_station_for_free.html
Live365 – Starting your own Internet radio station - www.live365.com/index.live

Creating your own online radio station - http://radio.about.com/od/createinternetradio/How_To_Create_Your_Own_Streaming_Internet_Radio_Station.htm

How to start an online radio show - www.ehow.com/how_2040362_start-online-radio-show.html

Sangean WiFi Radios

Now you can enjoy the excitement of accessing over 16000 Internet Radio Stations almost anywhere when you own a new Sangean Internet Radio and in addition enjoy any of your local standard FM broadcasts using the built in FM tuner with RDS (RCV56) or upload your favorite or any internet station to your Sangean's "My Station" allowing quick and easy future access. You no longer need to be glued to your computer to access your favorite Internet station nor do you even have to have your computer on. All you need is a broadband internet connection and a wired or wireless router. Add to your listening pleasure by creating your own Digital Music Library. Sangean WiFi radios offer the ultimate in Internet Radio listening.

GROVE

Order RCV56
\$279^{95*}

** plus \$19.95 UPS Ground shipping in the U.S.*

800-438-8155
828-837-9200 fax: 828-837-2216

www.grove-ent.com



BELOW 500 kHz

DXING THE BASEMENT BAND

Kevin Carey, WB2QMY
kevincarey@monitoringtimes.com

ID, Please?

Beacon hunters don't like the term "Unid." It's shorthand for "unidentified" and it means that the location of a station could not be determined. Some beacons stay in this status for quite a long time. Some prominent and recent Unids that come to mind are PYD, NEED, and TRY. There are usually several unidentified beacons on record at any given time. In my opinion, it's still worth logging these stations because it prompts others to listen for them, which may give some idea of location, based on signal strength, propagation traits, or direction finding. Most mystery beacons are eventually identified, though it may take years to reach a resolution in some cases.

Even if you're just a casual longwave listener, you need some way of identifying the stations you hear. This month we'll look at the many online resources for identifying beacons, plus one CD-based tool which I've begun using. Years ago, about the only option you had as a longwave DXer, was to obtain a printed copy of the excellent *Aero-Marine Beacon Guide* by Ken Stryker and Joe Woodlock (founding editor of this column), or to simply pour through lists of loggings from others in monthly publications. I had a copy of the *Aero-Marine Beacon Guide*, and treasured it as my main source of beacon information for several years.

Around 1994, I first came online with something known as the World Wide Web. Bits of information started to become available, mostly in the form of downloadable databases. Most of these were government lists, not intended for hobbyist use, but could nevertheless be helpful for those of us sifting through the basement band. Today, there are many excellent resources on the web, and best of all, they're free! Below are a few of my favorites, and I'd appreciate hearing from readers who have other online sites they recommend.

❖ World Aero Data

This site is aimed toward pilots and others in the aviation industry. To access it, simply go to <http://worldaerodata.com> and be sure to select "NavAids" (as opposed to Airports), and then you simply type in the ID you are searching for. By the way, the "Airports" tab can also be helpful for further research once you identify a beacon's location. It can help you understand the type of service the beacon is used for, and even provide a possible QSLing address.



❖ AirNav

AirNav is another excellent site that is easy to use. Log on to www.airnav.com to reach this site, and enter the ID that you are interested in. AirNav was one of the earliest online resources for beacons, and I recall speaking with the originator when I first discovered it, who found it surprising that people made a hobby out of DXing beacons! It was intended for pilots, of course. AirNav remains one of the most popular online tools for beacon chasers.



❖ North America Radio Beacons

William Hepburn's North America Radio Beacons site is focused on several types of utility stations, including weather, marine, and longwave beacons. Log on to www.dxinfocentre.com/ndb.htm to view the NDB listings. The site shows recent updates for new, decommissioned, or modified stations, which can be helpful if you're trying to get information on a new or missing station.

❖ PilotNav

While preparing this article, reader Todd Dockey KF6AWG (Alaska), wrote me to recommend the site at www.pilotnav.com, which he finds very helpful. I checked it out and had to agree that this one is worth having in my arsenal. A nice feature of the site is that you can either enter just an ID, or browse for navAids by geographic area, worldwide. In the case of browsing navAids in the United States, you get a selectable list of states. This could be especially useful for a DXer who is focusing on a particular area. You see everything that is available in a state and can get right to work trying to hear them.

❖ RNA Database

Quite likely the best NDB site today in both usability and completeness is the RNA Database

at www.classaxe.com/dx/ndb/rna. This site, created and maintained by Martin Francis (ON) has an amazing array of information available for beacon hunters in North America. You can enter either an ID or a frequency and get a listing of matching returns. You also see which other listeners have reported hearing a station and their geographic locations. The dates of last known loggings are also presented. A lot of work went into this site, and it is one of the first places I go when a question comes up about a North American beacon.

The RNA Database has become a favorite tool for many Beacon Chasers

❖ Going First Class

All of the online sites above are excellent resources, and I make use of them frequently. However, it is sometimes difficult to find lesser-known beacons, such as Locator Outer Marker (LOM) beacons that use a 2-letter ID. My local RO/400 kHz, is one such example. It is often omitted from general databases, though the RNA Database described above *does* show such stations.

For years, I had heard about a directory known as the *North American Non-Directional Beacon Handbook* (NANDBH) and had been meaning to pick one up. It's produced by beacon enthusiast Michael Oexner in Germany, and has a good reputation for accuracy and completeness. The guide is available in printed form or downloadable electronic format. Earlier this year I finally got around to ordering it. I decided to go with the electronic version, which can be obtained in a very short time by contacting Mr. Oexner and giving him the location of your listening station. He then prepares a customized

guide based on your actual location, which shows the compass heading and distance to every station on the list.

The NANDBH is not an inexpensive tool (my electronic version cost \$33; a printed copy would have been \$45, plus a \$2 PayPal fee), but it offers so many features for the DXer that I believe it is well worth the expense. I know of no other place to get a fully searchable directory centered on my location, which also includes pictures of NDBs, sound samples, maps, and lists of software. Over 5800 beacons are included in the North American version, and versions for Europe and other parts of the world are also available. Complete ordering information for this guide is available online at www.ndblast.info/beacons/NDBpublications2012.pdf.

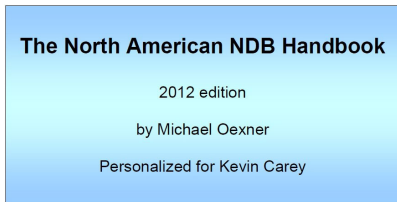

The North American NDB Handbook is personalized to your location for both distance and bearing information

❖ Loggings

Our loggings this month are courtesy of Richard Palmer W7KAM (Missouri) and Mario Filippi N2HUN (New Jersey). Table 1 shows a selection of loggings from both contributors. Richard uses an Icom R-75 receiver with an active antenna and a Timewave DSP599zx digital processor. Mario uses a Ten Tec RX-320d, and a Yaesu FT101ZD receiver with a Palomar VLF converter and a 43-foot vertical antenna.

Mario began his listening session on the 13th of July, and had this to say about his intercepts and background in longwave: "Well, Friday the 13th was not a bad luck day for me as I got several new catches: BA, HBD, CGE, YXL, PIX, YGV, YLD, and CH! Not bad for summertime listening. I liked your last column on why folks enjoy the low band. I always liked it because of its rich history, with ship traffic, beacons (both marine and aero), European longwave, and Lower experimenters. It's also the 'odd man out' as there are not many folks who know what goes on there.

"Longwave is also a very wide band and things are spaced out well. I had at one time a Third Class FCC commercial license and had to know about the international distress channel on 500 kc. On the quarter and three quarter hour all radio traffic had to cease for a few minutes so that seagoing ops and shore stations could listen for distress calls. That is gone now, but something still pulls me down there. Even as a kid I can remember that with certain transistor radios, if you tuned to the bottom of the AM band you might hear some Morse Code, and if not, I'd fiddle with the tuning capacitor to adjust it to hear that stuff. Keep up the great column!"

SELECTED BEACON LOGGINGS

kHz	ID	ST/PR/ITU	CITY	BY
206	QI	NS	Yarmouth	R.P. (MO)
223	YKA	BC	Kamloops	R.P. (MO)
227	TNZ	AR	Walnut Ridge	R.P. (MO)
233	BR	MB	Brandon	R.P. (MO)
239	HKF	OH	Middletown	R.P. (MO)
242	MMI	TN	Athens	R.P. (MO)
245	FS	SD	Sioux Falls	R.P. (MO)
248	PQF	TX	Mesquite	R.P. (MO)
253	GB	MN	Marshall	R.P. (MO)
254	BOZ	IL	Sterling	R.P. (MO)
257	SQT	FL	Melbourne	R.P. (MO)
260	AP	CO	Denver	R.P. (MO)
260	AVZ	TX	Terrell	R.P. (MO)
260	BVQ	KY	Glasgow	R.P. (MO)
263	GR	MI	Grand Rapids	R.P. (MO)
269	SWT	NE	Seward	R.P. (MO)
278	EOE	SC	Newberry	R.P. (MO)
284	VIV	LA	Vivian	R.P. (MO)
311	DVK	KY	Danville	R.P. (MO)
314	VTN	NE	Valentine	R.P. (MO)
323	OUK	GA	Calhoun	R.P. (MO)
329	CH	SC	Charleston	M.F. (NJ)
332	CAO	NM	Clayton	R.P. (MO)
332	FIS	FL	Key West	R.P. (MO)
335	YLD	ON	Chapleau	M.F. (NJ)
340	YY	QC	Mont-Joli	M.F. (NJ)

344	BKU	MT	Baker	R.P. (MO)
344	PIX	PA	Picture Rocks	M.F. (NJ)
344	TKH	LA	Tallulah	R.P. (MO)
344	YGV	QC	Havre-St Pierre	M.F. (NJ)
346	THJ	MS	Laurel	R.P. (MO)
346	YXL	ON	Sioux Lookout	M.F. (NJ)
350	OKT	TX	Yoakum	R.P. (MO)
351	YKQ	QC	Ft. Rupert	M.F. (NJ)
355	CGE	MD	Cambridge	M.F. (NJ)
360	PN	QC	Charlevoix	M.F. (NJ)
363	RNB	NJ	Millville	M.F. (NJ)
367	PRI	MO	Farmington	R.P. (MO)
369	TT	NJ	Trenton	M.F. (NJ)
378	RJ	QC	Roberval	M.F. (NJ)
379	BRA	NC	Asheville	R.P. (MO)
390	JT	NL	Stephenville	M.F. (NJ)
391	DDP	PR	San Juan	R.P. (MO)
391	DDP	PR	San Juan	M.F. (NJ)
391	GXD	TX	Nacogdoches	R.P. (MO)
392	ML	QC	Charlevoix	M.F. (NJ)
392	ML	QC	Charlevoix	M.F. (NJ)
396	NEL	NJ	Lakehurst	M.F. (NJ)
397	CIR	IL	Cairo	R.P. (MO)
400	CI	MI	Sault St. Marie	R.P. (MO)
400	UWI	GA	Dalton	R.P. (MO)
404	YSL	NB	Ft. Leonard	M.F. (NJ)
407	AQ	WI	Appleton	R.P. (MO)
407	FR	NY	Farmingdale	M.F. (NJ)
408	HBD	OH	Hubbard	M.F. (NJ)
409	YTA	ON	Pembroke	M.F. (NJ)
410	BA	IN	Columbus	M.F. (NJ)
410	GDV	MT	Glendive	R.P. (MO)
414	OGY	NY	NYC	M.F. (NJ)
415	CBC	CYM	Cayman Brac	R.P. (MO)
417	SLP	NC	Shelby	M.F. (NJ)
419	RYS	MI	Detroit	M.F. (NJ)
420	TU	MS	Tupelo	R.P. (MO)
428	SYW	TX	Greenville	R.P. (MO)
432	IZN	NC	Lincolnton	M.F. (NJ)
526	ZLS	BAH	Stella Maris	R.P. (MO)

Note: An online list of ITU codes is available at <http://tinyurl.com/ITU-Codes>

NOW AVAILABLE

Radio hobbyists interested in receiving and identifying radio stations in the HF/VHF/UHF radio spectrums now have a new whopping 1414 page CD-ROM publication to aid them.



International Callsign Handbook is a concise world directory of various types of radio station identifications covering the military, government, maritime, aeronautical, and fixed radio stations on CD-ROM. Thousands of callsigns and other types of identifiers have been collected from our own personal log book, official sources and dedicated hobbyists who contributed their material.

World QSL Book - Radio hobbyists interested in receiving verifications from radio station now have a new CD-ROM publication to aid them in the art of QSLing. This 528-page eBook covers every aspect of collecting QSL cards and other acknowledgments from stations heard in the HF spectrum.

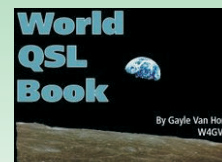

"I'm impressed. This is a comprehensive collection of worldwide radio identifiers likely (and even some less likely) to be heard on the air. Over the years the Van Horns have earned the well-deserved respect of the monitoring community. Accurately assembling a collection like this is a mammoth undertaking. Congratulations on a job well done."
Bob Grove - December 2008 What's New Column, Monitoring Times magazine

Both books may be ordered directly from Teak Publishing via email at teakpub@brmemc.net or via our two main dealers, Grove Enterprises, www.grove-int.com, and Universal Radio, www.universal-radio.com.

TEAK
Publishing
PO Box 297
Brasstown, NC 28902
teakpub@brmemc.net

From Teak Publishing either book is \$19.95 plus \$3.00 (US) and \$5.00 (Int'l) first class mail. Paypal, Cash, Check or Money Order accepted. NC residents add state sales tax.
Dealer inquiries/orders welcomed.



RADIO RESTORATIONS

BRINGING OLD RADIOS BACK TO LIFE

Marc Ellis, N9EWJ

marcellis@monitoringtimes.com

The Howard 430—A Brand New Project

A few weeks ago, a friend of mine with a really extensive collection of communication receivers announced that he was thinning out his holdings a bit. When I heard that some Howard receivers were slated to go, I perked up my ears. I had wanted to get my hands on one ever since I saw my first example. I liked the rounded top corners of the cabinets on most models, as well as the neat slide-rule dials with their tricky semi-circular inserts for the bandspread and band indicators. Style features such as these are rare among other communication sets of the era (late 1930s).

But it's not easy to find a good Howard radio! All Howard models are listed as very scarce in Fred Osterman's *Shortwave Receivers Past and Present*. Not only that, but many of the ones that do turn up are afflicted with the same discouraging disease: extensive rusting of the metal plate carrying the calibrations and other dial markings--obliterating much of the information. Apparently the flaw was caused by something amiss in the chemical composition of the metal dial or its coatings.

I was pleased to find that the ones in my friend's collection had somehow escaped this nasty fate, and I picked out a Model 430, which happens to be the smallest in the line. This 6-tube set is one of the few Howard Models having a series of shiny parallel metal strips wrapping around the top and sides of the cabinet, really enhancing its nostalgic Art Deco look.

❖ Howard History and Products

Before we begin examining my acquisition, let's talk about the Howard Company and its radios. Much of what I've been able to find in print about the firm comes from radio historian Alan Douglas. In his biography of the Howard Company in *Radio Manufacturers of the 1920s, Volume 2*, Douglas reports that, by 1927, founder Austin Howard had a thriving business selling Neutrodyne-licensed broadcast radios. In mid 1927, he obtained an RCA license that was going to require him to pay a minimum royalty of \$100,000 per year. This was a very large commitment for the medium-sized firm, and Howard responded by substantially increasing both his output of sets and the variety of his models.

With the onset of the Depression in 1929, sales slumped and Howard lost control of his company but regained it in 1932 when he transferred operations to the McMurdo Silver plant. (Silver was a manufacturer of radio parts as well

as broadcast and all-wave receivers.) Thanks to Howard's RCA license, he was able to supplement his income by building radios for smaller firms that were not licensed, including Hallcrafters and Silver. Though Silver had moved out by 1934, Howard stayed on at the same Chicago location continuing to manufacture communication and broadcast receivers until at least 1948.

Howard was unusual in being one of the few, perhaps the only, major manufacturer of communication receivers with a serious line of broadcast sets. But right now our major interest is in the communications models. Raymond Moore's *The Vacuum Tube Era: 1932-1981* shows 14 of them: the 430 (6 tubes); 435 (6 tubes); 435-A (7 tubes); 436 (7 tubes); 436-A (8 tubes); 437 (9 tubes); 437-A (9 tubes); 438 (8 tubes); 440 (9 tubes); 445 (6 tubes); 450 (12 tubes); 450-A (12 tubes) 460 (10 tubes) and the behemoth 490 with 14 tubes. All of these receivers share the same dial design as the 430,

with the exception of the 440, 450, 450-A, and 490. Those have a more utilitarian, businesslike appearance in keeping with their more advanced circuitry.

Looking over the production dates in the Moore book, it's interesting to note that these sets first appeared in 1938 and no less than six of the models were on the market by 1939. Five more had appeared by 1941 and the rest by 1942. All this was going on concurrently with what seemed to be a complete line of consumer broadcast sets. The Howard plant must certainly have been a beehive of activity during those productive years!

❖ About the Howard 430

The Howard 430 is a basic 6-tube superheterodyne shortwave receiver similar electrically to the more recent Hallicrafters S-38 and National SW-54, both of which were introduced after World War II. However unlike the latter two, which are AC-DC and have five tubes, the 430 has a transformer power supply and six tubes. The extra tube is a beat frequency oscillator, not required in the other sets, in which BFO action was obtained by controlled introduction of feedback in the IF stage.

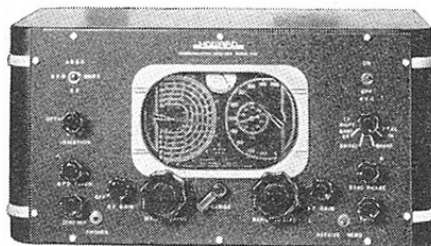

Detail from a Howard ad, showing, from bottom, models 430, 438, and 450-A.



The Howard 430 as received.

The radio is compactly built, housed in a heavy-gauge steel cabinet, and has a substantial feel that suggests high quality construction. The 430's tube complement is as follows: 6K8 oscillator-mixer, 6K7 IF amplifier, 6Q7 detector/1st audio/AVC, 6C5 BFO, 41 audio output and 5W4 rectifier. The tuning range is 0.55 - 42 MHz in four bands: 0.55-1.7, 1.7-5.5, 5.6-18, and 16-42 MHz.

On the front panel are knobs controlling main tuning, tuning range, bandspread, volume and BFO pitch. Four slide switches control the set's power, turn the BFO and AVC on and off,

and mute the receiver while sending. On the rear apron are antenna and ground terminals, a 4-prong socket for supplying external power and connecting an accessory S-meter, a headphone jack and terminals for an external speaker. The presence of the 4-prong socket makes this set a 430 Series 2. The earlier model without the socket does not have a series designation.

❖ Getting Inside the 430

As received, this radio was as nice cosmetically as any set I've ever worked on. Even the line cord looked OK, which is a rarity. About the only problems visible from the outside of the cabinet were slippage in the tuning dial drive and the need for a replacement band indicator dial cord. It did look like the crackle finish on the back panel had been rejuvenated by rubbing in paint of a shade that doesn't quite match, but the job was nicely done and hardly noticeable.

It was now time to get inside the 430, which turned out to be a bit of a trick. I wasn't going to be sliding the chassis out the front or back of the cabinet because the cabinet was all in one piece, open only at the bottom. So the chassis would have to be dropped out. I removed the knobs, which would obviously have to come off, but wasn't sure how their shafts would clear the cabinet front, not to mention all the slide switches, which seemed to be attached to the front panel.

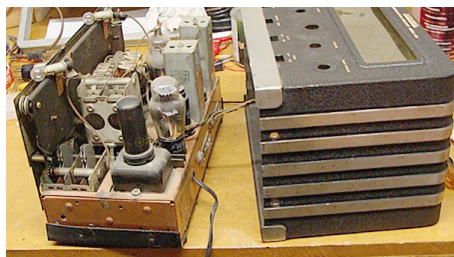

The 430 as removed from its cabinet. Dark strip in lower foreground of chassis is part of the mounting bracket.

After a little bit of experimentation, here's what I discovered. The cabinet bottom plate, on which are mounted the radio's rubber feet, is attached to the bottom of the chassis with two screws. The "plate" is actually part of a U-shaped bracket that secures the chassis to the cabinet. This is done via two screws in each side of the cabinet, near the bottom, that mate with threaded holes in the bottom plate/bracket.

To remove the chassis, one leaves the radio right-side up on the bench and removes the four side screws. The bottom screws are to be left in place. The chassis, with bracket attached, is now free of the cabinet. There is enough clearance between the chassis rear apron and the back of the cabinet so that the cabinet can be slid forward enough to clear the control shafts. It also clears the slide switches which, it turns out, are actually attached to the chassis with their actuators protruding through holes in the front panel.

The cabinet, which includes the top-mounted speaker, can now be lifted free of the chassis. It can be set aside once the speaker is unplugged.

Getting my first good look at the chassis, I was quite impressed. Some of the Internet comments I've read about this radio had led me to expect lackluster performance. But if the excellent construction practices used in the radio count for anything, I'm expecting the 430 to be a hot little receiver. The quality components were carefully laid out on the copper-plated chassis and rigidly mounted where it was important. This was not a set where corners had been cut, mechanically or electrically. I'm really looking forward to trying it out!

❖ Preliminary Inspection and Testing

Examining the radio above and below the chassis, I was pleased to find no evidence of overheated or burned components. I did notice a 1-volt Mallory bias cell associated with the first audio tube and made a mental note to either rejuvenate it if possible or come up with a substitute.

As always, I check out the power transformer very early in any restoration. It's very difficult, and expensive, to find a transformer that exactly fits the electrical and physical requirements for a given set. To avoid sending DC into the circuitry while checking the transformer, I removed the rectifier tube from its socket. As soon as I plugged the radio in and turned it on, the two vintage spherical dial lamps immediately lit up with a warm glow, as did the heaters of the two glass envelope tube still in the radio. (The others had been replaced by metal versions somewhere along the line). So the power transformer's 6.3-volt heater winding was OK.

With the radio still powered up, I measured 600 volts across the plate pins of the rectifier tube socket and 300 volts from each pin to ground. And, I found the expected 5 volts across the filament pins. Now I knew that the transformer was functioning as it should. While I had my multimeter out, I checked the speaker voice coil and field coil windings by measuring the resistance across the appropriate pins of the speaker plug. Proper readings were observed for both.

Finally, I removed all of the tubes, checked to make sure that the correct types had been plugged into the sockets (they were) and tested each tube. During the testing, I noted that the 6K8 (one of the two glass types) had a loose grid cap. However the vacuum seal was still intact because the tube tested OK. The 41 audio output tube tested strangely. The expected meter reading was about 40 (about 1/3 scale), but instead the meter was pinned, so I had to let go of the test button instantly. An internal short might have caused this problem, but nothing had shown up in the shorts test. I'll have to locate another 41 and try it out to determine if I am dealing with a bad tube, a misprint in the tube chart, or a problem with the tube tester. Next month I'll dig a little deeper into this interesting radio.

❖ From the Readers

Lynn Kelly commented on several points in my item, "Don't Plug These Sets In," in the August issue. He mentions that 110-volt DC

radios were not only used in the areas of big cities still served by 110-volt power but also in ships built prior to the 1960s and in 110-volt wind and Delco systems.

32-volt wind systems were more commonly used in marine and railroad applications than on farms, which were much more apt to have the 6-volt "radio chargers" that were sold by the millions. The railroads used countless 32-volt systems to power signal lights at remote crossings. As for my comment that some farmers installing 32-volt systems used 110-volt wiring devices to be ready for rural electrification power when it came, Lynn comments that this dangerous practice was forbidden by the National Electrical Code.

Jim Austin KE7MVO, formerly W9GDU, had a school buddy whose family home had a 32-volt Delco system which was later changed over to 110 volts AC. Much later, since the plug fit, someone decided to fire up one of the 32 volt radios on the 110-volt system. Jim's friend showed him the fried results.

Our recent series on the Arvin 444A took Jim on a trip down memory lane. He had one as a kid, in fact it was his first radio. Eventually the bypass capacitor on the floating ground shorted out so that the metal cabinet was connected to one side of the line. Since he liked to listen to Jack Armstrong and Tom Mix while sitting near a grounded hot air register, he was occasionally knocked back on his rear. He says his eyes still flicker when he thinks about it.

Don Jensen has been following my column for many years and thought it was about time to say hello. Glad you did, Don! He has several metal midget sets similar to the Arvin whose restoration was completed in the last issue and has recapped them all. Like me, he prefers not to disturb original connections when recapping. Jim cuts off the leads of a component being replaced a short distance from their connections. He then prepares the replacement capacitor by coiling its leads around a straightened paper clip. The prepared leads can now be slipped over the old leads and soldered in place.

Join the AWA

ANTIQUÉ WIRELESS ASSOCIATION
THE ORIGINAL AND LARGEST HISTORICAL RADIO-COLLECTOR GROUP

- Publishes *AWA Journal* with:
 - Battery and AC receiver restoration
 - Vacuum-tube history and collecting
 - Old-time amateur-radio contests
 - Communications receivers
 - Free want-sell-swap ads
 - Early television
 - Horn loudspeakers
 - Reviews of current books
 - Keys and land-line telegraphy
 - News of U.S. and foreign clubs
 - Information on public radio museums
- Maintains unique radio-TV museum.
- Produces the annual Rochester meet.
- Co-sponsors local meets.
- Publishes the annual *AWA Review*.



Membership is only \$25 per year U.S.A. (\$30 per year elsewhere). Write to:

AWA Membership Director
PO Box 421, Bloomfield, NY 14469-0421

www.antiquewireless.org



A Flock of Other Amateur Radio Satellites - Part II

In previous columns, I've been sharing information about the mainstays of our amateur radio satellite fleet and how you can receive their signals or, if properly licensed, actually work through those that have transponders. In this installment, I'll continue the discussion I started in the August issue about a number of other amateur satellites (called "CubeSats") that have been launched in the last few years. I'll then once again bring you up-to-date on some of the latest happenings in the amateur satellite world.

So, let's begin by shining the spotlight on a few more CubeSats that were still in orbit and operational at press time (late August, 2012). However, and as I've noted previously, because the lifetimes of these satellites are all relatively short, they may (or may not) still be operating by the time you read this.

❖ RAX-2

Weighing in at just over 3 Kg, RAX-2 (short for "Radio Aurora Explorer") is a 3U Cubesat that was successfully launched on 28 October 2011 from Vandenberg AFB, California, into a 810 x 330 Km, 101 degree inclined (polar) orbit.

The primary mission objective for the RAX-2 mission is to study the formation of so-called "Field Aligned Irregularities" (FAI) in the lower portion of the polar ionosphere. To seek out these anomalies, a ground-based radar transmitter is used in conjunction with the space-based receiver onboard RAX-2 to measure FAI intensity, altitude distribution, and degree of alignment to the Earth's magnetic field. This ground-based radar (called the Poker Flats Incoherent Scatter Radar, or PFISR) transmits RF pulses into the ionosphere to be scattered off the

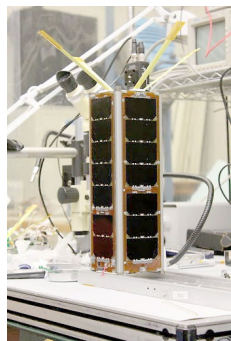

The flight model RAX-2 satellite is shown here just before launch. Note the carpenter's rule, steel tape antennas. (Courtesy: University of Michigan)

FAI structures. The received signal magnitude and phase is then recorded and processed by the satellite and later downloaded for analysis by the mission science teams.



Brian Klofas KF6ZEO shows off a "PeaPod" CubeSat launcher at a recent AMSAT-NA Space Symposium. (Courtesy: Author)

❖ SwissCube

SwissCube is the first satellite built entirely in Switzerland. It was developed at the Ecole Polytechnique Fédérale de Lausanne (EPFL) in collaboration with several Swiss engineering schools, universities, and private firms. The motivation to build and operate SwissCube is primarily to educate Swiss students in space technologies and space system engineering. The satellite launched in September 2009 and had a design lifetime of 3 years, although that goal has now been exceeded.

Built as a 1U CubeSat, SwissCube was successfully launched on 28 September 2009 from the Satish Dawan Space Center in India into a 752 X 726 Km, 98-degree (i.e. polar) orbit. Power is supplied by a 1.5Watt solar array with two 1.2Ah lithium-ion polymer batteries. Attitude determination and control is achieved with 6 sun sensors, a three-axis magnetometer, a gyro, and numerous temperature sensors.

SwissCube's onboard science mission is to observe the "airglow" phenomenon, defined

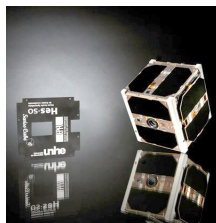

A cutaway view of one of the circuit boards carried aboard the SwissCube satellite along with a photo of the completed flight model spacecraft. (Courtesy: EPFL)

OF CUBESATS AND PEA PODS

Sometimes called "nanosatellites," these tiny little satellites have generated a whole new satellite nomenclature all their own. For example, you will sometimes hear these satellites referred to as "1U", "2U" or "3U" CubeSats. A 1U CubeSat is the smallest of the lot, measuring only about 4 inches on a side. A 3U Cubesat structure consists of three, 1U-sized CubeSats stacked one on top of another. Some of the larger CubeSats (of the "3U" variety) may also sport deployable solar panels, thus giving them extra power for communications, for onboard experiments, or (more importantly) to keep their batteries warm during eclipse.

However, because they *are* so tiny, several of these satellites can be launched from a single rocket's upper stage, usually by means of an innovative launch mechanism called a "Pea Pod." In many ways this launcher approach resembles one of those spring-loaded cloth "snakes in a can" we used to buy from a joke shop that quickly spring out when an unsuspecting victim opens the lid.

Likewise, before launch, the CubeSats are all pushed into one or more of these spring-loaded PeaPods mounted on the upper stage of a rocket. There's usually room for three, 1U CubeSats or a single 3U version in each PeaPod and multiple Pea Pods can be carried on a single rocket's upper stage.

Prior to launch, the spring-loaded "trap door" on the front of the Pea Pod is closed and firmly latched using a small, electromechanical deployment mechanism. Later, when the upper stage of the rocket achieves orbit, the spring-loaded "trap door" is opened, and out pop the satellites, one by one, into their own orbits.

as the photoluminescence of the atmosphere that occurs at approximately 100 km altitude. SwissCube carries a tiny (767-nm!) telescope that captures images with a resolution of 188 x 120 pixels. Unfortunately, soon after launch, SwissCube was rotating at a high spin rate, which prevented use of the camera. However, this spin rate has since slowed enough for SwissCube's ground handlers to turn the camera on and start taking pictures of the Earth's upper atmosphere.

The SwissCube project's live tracking website (swisscube-live.ch/Home/OfficialData) shows real-time telemetry gathered from ground

control and amateur radio stations and also provides other links to the SwissCube project.

❖ PRISM

PRISM is a project of the University of Tokyo Intelligent Space Systems Laboratory (ISSL). PRISM is an acronym for "Pico-satellite for Remote-sensing and Innovative Space Missions." Its nickname, hitomi, means "eyes" in Japanese.

PRISM was successfully launched on 23 January 2009 from the Tanegashima Space Center in southern Japan. PRISM was initially planned to have a 6-month mission and an expected 1- to 2-year lifespan, both of which have now been exceeded. The primary mission of PRISM is to capture images of Earth using an extendable optical system. A secondary mission provides amateur radio frequency communications for education purposes. Both objectives have since been met many times over.

PRISM obtains its 10-m resolution images using a color CMOS area imager (1280x1024 pixel image size). This relatively high resolution from a small satellite was achieved by deploying the lens on an extendable boom mechanism that was successfully deployed on 27 February 2009. A second CMOS area imager, with a nearly 1000-Km² field of view, captures images over a wider area and is used to determine where to point the narrow field imager. Power is supplied to the satellite by a Gallium Arsenide solar array charging lithium-ion polymer batteries. Attitude determination and control is achieved

with magnetometers, gyros, a small magnetic torquer, and a sun sensor. At press time, only the 50 WPM CW telemetry beacon was operational. More information about the PRISM mission is at: www.space.t.u-tokyo.ac.jp/prism/en/main.html.

❖ Project FOX Update

In my August column, I brought you up-to-date on AMSAT-North America's next big project...a CubeSat design of our own we call "FOX." As you may recall, back in February 2012, FOX-1 was awarded a berth on an upcoming NASA ELANA (Educatoinal Launch of Nanosatellites) mission.

Over the last few months, FOX-1 experimenters have been very busy "building stuff" to use the words of AMSAT-NA's Engineering Vice President Tony Monteiro AA2TX. Tony reports that members of the FOX-1 Team are also now making good progress prototyping and populating circuit boards as well as putting the finishing touches on the final spacecraft structural design.

During the past academic year, senior engineering students at Penn State University were also designing FOX-1's sole experimental payload; to see if the use of ordinary MEMs (short for "MicroElectroMechanical Systems) gyro sensors can be used to directly measure both the spin and "wobble" rate of the satellite in orbit. MEMS components consist of tiny mechanical devices built into micrometer-sized semiconductor chips that are most often used here on Earth as vibration sensors as well as for

accelerometers in vehicle airbags, pacemakers and video games.

Tony reports that all the Penn State engineering students working on the project have successfully graduated and have turned over their handiwork to AMSAT's experimenters. The FOX Team is now in the process of also integrating the Penn State designs into the flight model spacecraft.

AMSAT's Fox-1 project timeline is still anticipating a launch sometime in the second half of 2013. However, NASA has yet to determine on which specific flight each of the Project ELANA CubeSats will be carried to orbit. So, as I noted earlier, the launch timeline for FOX-1 could very well slip...or be accelerated... depending on NASA's other launch needs. In the meantime, the latest on FOX-1's status can always be found on the FOX-1 Web page at: www.amsat.org/amsat-new/fox.

❖ Looking Ahead

That's all for this time. I trust you are still having fun tracking the beacons and downloading some of the telemetry of these tiny orbital wonders, as well as listening for (or communicating through) our other transponder-equipped amateur satellites.

In future columns, I'll continue to bring you up-to-date on the progress of the FOX-1 effort as well as the status of some of our other amateur satellites still in orbit.

See you then!



WORLD CLASS PRODUCTS

"BLAST OFF!"

M² offers a complete line of top quality amateur, commercial and military grade antennas, positioners and accessories.

We produce the finest off-the-shelf and custom radio frequency products available anywhere.

For high frequency, VHF, UHF and microwave, we are your one stop shop for all of your high performance RF needs.

M² also offers a diverse range of heavy duty, high accuracy antenna positioning systems.

Whether your communication needs are across town, around the world or beyond, M² has World Class Products to suit your needs.



M² products are proudly 'Made in the USA'

4402 N. Selland Ave.
Fresno, CA 93722
Phone (559) 432-8873
<http://www.m2inc.com>
sales@m2inc.com

ANTENNAS POSITIONERS ACCESSORIES



DIY Computers

Remember when we had to make our own computers? In the early days of personal computers (circa 1980), it was common to build a Heathkit computer, or cobble one together by buying a case, motherboard, memory, video interface and so on. Interfacing the computer's limited I/O to your radio equipment often meant hours of work building the necessary circuits. Software was hard to come by, so you often had to learn to program and write your own!

Seeing that a revolution was underway, many companies, some now extinct, rose to the occasion, offering expensive solutions that, over time, got bigger and better. Well, some would argue otherwise, but we're speaking in generalities here! The big industry shakeout in the late 1980s left only a few big companies standing. With the high volume of PC sales worldwide and declining prices, it seems like there might be little point today in "rolling your own." Or is there?

I wanted to see just how hard, or easy, it could be to make your own computer today and how much it might cost compared to pre-built versions. I had a few basic requirements:

The parts had to be standardized so that I could buy from multiple sources; upgrades and replacement parts would still fit. I didn't want to have to write a purchase order to buy anything; no sales reps, just stuff that's easy to buy, preferably online, but I also wanted to see if there were any computer retailers left.

I wanted portability without having to buy a laptop. Since that means external monitors, keyboards and mice, I wanted an easy way to transport all that and I wanted more sound card performance than I could get with a laptop or the HD audio on a motherboard (which are inherently electrically noisy). I wanted it to run on the same 12V supply I use for my radio equipment.

❖ Standardization

The PC motherboard is the heart of the modern computer. Intel and AMD have dominated the chip market for years and their products form the core of the product. Peripheral chips have made it easy for many companies to offer boards and the form factors have become standardized. Connectors have also been standardized, allowing many companies to provide power supplies, fans and other needed components.

Figure 1 shows the various configurations of PC motherboard that have been created. I chose the "Mini-ITX" form factor as a nice

compromise between a full-blown model with many extra slots that I didn't need, and smaller architectures, such as PC-104, which are harder to get. So much high-performance I/O is now built in to most motherboards that the days of needing a lot of slots are dwindling.

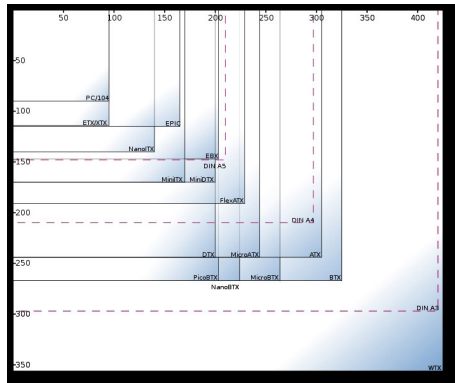

Various sizes of motherboard

Power supplies have been a consistent size for some time, but they are all 120/240V AC models designed to handle way more than the typical radio shack needs. Luckily, there is a solution; high efficiency switchers not much bigger than the power connector that they plug into. Figure 2 shows one such model made by Mini-Box (www.mini-box.com).

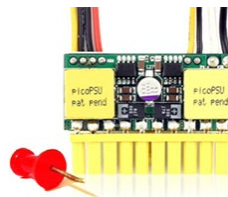

Mini-box DC-DC converter for mini-ITX motherboards

Since I wanted the whole thing to run from DC, and much of my ham radio equipment uses Anderson Power Pole (APP) connectors, I thought it would be useful to put APP connectors on the rear panel and allow them to be daisy-chained to other equipment. That would also bring in the power which could be connected to an ammeter and voltmeter circuit for display on the Panel Pilot.

Normally, for the ammeter to work properly, current must flow through sense resistor in only one direction. With this unique circuit, the otherwise unused second half of U1 can be used to detect current in the other direction and whichever op-amp is actually generating a voltage will then feed that voltage out to the display. The other op-amp would not generate an output, keeping the associated transistor turned off and

allowing Q1 and Q2 to be wired. I also added a jumper to allow the circuit to be powered from switched power (coming from the PC's peripheral power outputs) or raw unswitched power. I figured that I might or might not want to see the display active when everything else is turned off.

❖ Sources for Parts

There are many places online where you can get all the parts necessary to build your own PC. However, there are often as many unhappy buyers as happy ones; customer service is still hit-or-miss with many online retailers. My experiences have always been good, so I can recommend the ones listed here:

TigerDirect (www.tigerdirect.com) I ended up buying a Biostar TH61 motherboard, solid state hard drive (SSD), Intel i7 Quad Core 3.4GHz processor, 8GB of DDR3 1600Mhz memory, and an ASUS Sonar Essence STX high performance sound card and Microsoft Windows 7 Professional for about \$900. While I could have spent far less to get a very competent PC, the order process was painless and the order was delivered within two days.

Amazon (www.amazon.com). Amazon, as you may know, ships goods from all over the world from a huge variety of sellers. I bought a StarTechPCI Express "Riser" cable from them. Since I had ordered from Amazon before, it was a very quick matter to arrange for one-click purchasing.

Microcenter (www.microcenter.com). This is one of only a handful of stores left where you can still wander the aisles looking for just the right thing. I spent a lot of time in the DIY section, looking at fans, cables, motherboards, processors, cases, power supplies and more. I have to admit, I much prefer this to online purchasing. However, prices are generally higher and selection is not necessarily as good. Microcenter has stores in California, Colorado, Georgia, Illinois, Kansas, Massachusetts, Maryland, Michigan, Minnesota, Missouri, New Jersey, New York, Ohio, Pennsylvania, Texas and Virginia.

❖ Sound Cards

Motherboards typically have "24-bit" HD sound card capability built-in. But demanding amateur radio applications, especially DSP, require much more dynamic range than what you actually get on a motherboard. The board is

typically so electrically noisy that you can only get about 80-90dB of dynamic range, whereas a true 24-bit system is theoretically capable of 150dB, with over 120dB realistically achievable. I found a dedicated, shielded sound card made by ASUS, called the Xonar Essence STX, a PCI Express card that claims to have 124dB of signal-to-noise capability. In order to fit it in the chassis I selected (see next section), I also needed a “PCI Riser” cable (made by StarTech). This is an extension cable that allows cards to be situated somewhere else other than plugged vertically into a motherboard. This is often needed in “servers”, which are rack-mounted PCs that are often not tall enough to accommodate standard PCI-sized cards. See Figure 3.



ASUS Essence STX sound card and StarTech “Riser cable”

❖ Cases

Although motherboards and many peripherals have been standardized, cases have not. But there are many choices. In fact, there are some creative individuals who have built computers into replicas of unusual items such as toy cars, robots, and even toasters.

Manufacturers of assembled PCs must test the product for radio emissions and radio susceptibility. Anyone who has tried to use a poorly shielded computer too close to their radio knows the problem. VGA cables and monitors can radiate all over the shortwave spectrum. Simply moving the mouse can cause perceptible hash in a received radio signal.

When you build your own PC, you must take this into account. The FCC (and other worldwide regulatory agencies) cannot regulate emissions from a computer that you assemble for yourself. Most cases today are plastic, although most have conductive interior surfaces that attenuate radio emissions.

Perhaps the best bet would be an aluminum or steel enclosure, but they can be pricey, since they would not be sold by the millions, which would bring the price down. You can still buy aluminum project enclosures and prefabricated metal chassis from companies like Bud (www.budind.com), Buckeye Shapeform (www.buckeyeshapeform.com) and Equipto (www.equipto.com), but it will require more work on your part to drill mounting holes in just the right spots.

Fortunately, as a manufacturer of ham radio equipment, I had access to a spare DZKit Sienna chassis. By eliminating a couple of interior brackets, I was able to create a space large enough to hold a mini-ITX motherboard, an RFSpace SDR-IQ and a solid-state hard drive, with room to mount one PCI Express card sideways too. All I had to do was remove some captive standoffs and drill some new holes for new standoffs that would hold the motherboard.

Figure 5 (above) shows the motherboard, hard “disk” (not really appropriate to call it that since it’s got no moving parts!), SDR-IQ and ASUS 24-bit HD sound card mounted to the chassis. The front panel is not finished yet, but in the photo you can see the beginnings of a very cool design. I wanted to have a dual meter to display voltage and current, and I found a “PanelPilot” (www.panelpilot.com), which is a color LCD display with built-in voltmeters for two inputs. The scales are semi-customizable by running free software and downloading the chosen scales into the meter over a USB port. The SDR-IQ Receiver is shown at bottom right in this picture. Its USB port connects to one of the internal USB ports on the motherboard.

Figure 6 (below) shows the rear panel view of the PC chassis. This PC motherboard has 3 video ports (HDMI, VGA and DVI, 2 usable at a time), PS/2, HD audio, Gigabit Ethernet, 4 USB 2.0 and 2 USB 3.0 ports (plus additional ports inside). Note the storage compartment for a small wireless keyboard/mousepad and the sideways mounting of the ASUS soundcard via the PCI Express Riser cable.

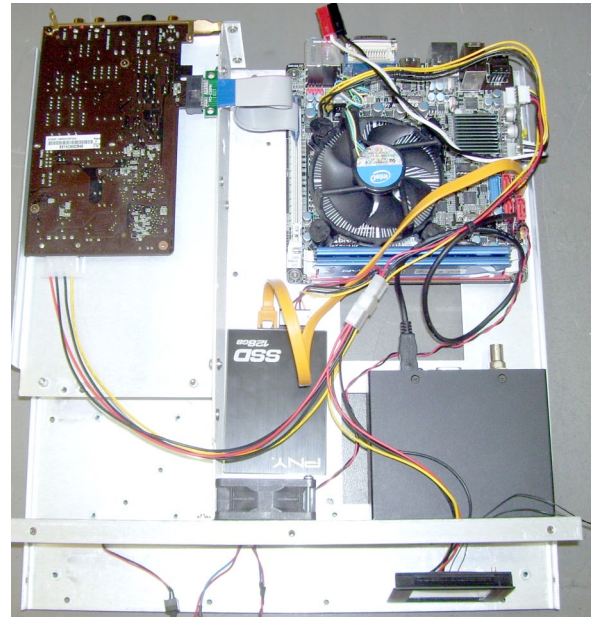

The Beginnings of a shielded metal case for the PC and related equipment using a modified DZKit Sienna chassis. The SDR-IQ Receiver is shown at bottom right in this picture. Its USB port connects to one of the internal USB ports on the motherboard.

❖ Firing it Up

I had to attach a USB DVD to install Windows, but it was very painless. The SSD allows Windows to boot in about 15 seconds, and it shuts down in about 5. If you use the PC for rig control applications and keep it off the Internet, you don’t really even need antivirus protection, which can slow down a PC greatly. The ASUS soundcard driver did not want to install, but an email to ASUS customer service resolved that quickly.

I attached two monitors to the video ports, but admit I had to “phone a friend” to figure out how to get them to work in the extended desktop. Turns out I also had to install drivers that were included with Windows 7, but this also did not take very long once I realized I had to do so!

Within about two hours after receiving everything, I was listening to music CDs through the ASUS sound card. The whole process was not bad at all. If you are willing to do some of the work yourself, you can create just the right PC for you.

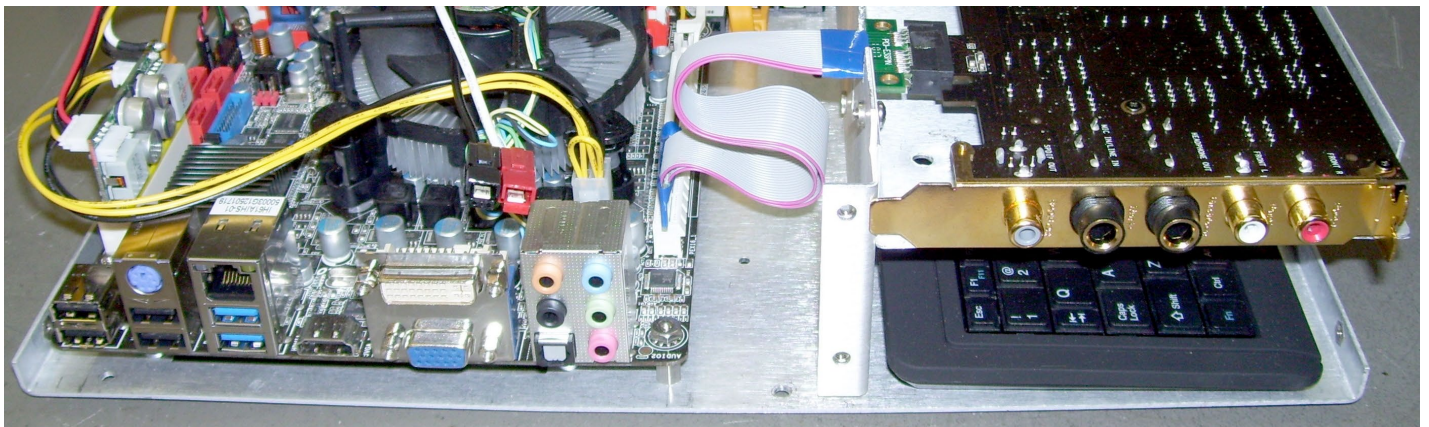

Newstar DR111 Digital Shortwave Receiver

By Ken Reitz KS4ZR (Photos courtesy the author)

Over the years *MT* has reviewed dozens of well-designed portable shortwave radios. They are usually inexpensive, under \$200, and have many features that have come to be standards among the genre. There has also been an industry movement towards Software Defined Radios (SDRs) that are typically much more expensive and require a considerable laptop or desktop to anchor the radio capabilities of these sets. One unique aspect of SDRs is that they can tune in Digital Radio Mondiale (DRM) transmissions, the European-based digital broadcast scheme. DRM promises clear, high-fidelity, stereo broadcasts on the shortwave bands and has the potential to revolutionize shortwave broadcasting. The Newstar DR111 would like to be an inexpensive shortwave radio with DRM reception capability.

❖ DRM's Glacial Progress

As North American shortwave listeners, we're been tantalized by the prospect of listening to DRM broadcasts for years. Yet, DRM seems no closer to most of us now than ever. Why? Partly this is due to the concentration of DRM progress on the European continent, partly it's due to the fact that digital broadcasting in the U.S. has meant HD-Radio; the scheme begun by iBiquity, a consortium of stateside broadcast interests launched ten years ago to bring digital radio to the American AM and FM bands. As you might expect, iBiquity's digital and DRM's digital transmissions are incompatible.

One of the biggest drawbacks to DRM broadcasting is that, like our digital TV transmissions, if you can't capture a big enough signal, the digital data that makes up the broadcast fails to produce any audio. On a typical shortwave frequency the signal is basically only viable for less than 1,000 miles which makes it perfect for European broadcasts but not so perfect outside Europe.

Earlier attempts to produce and sell a portable DRM-capable set in the U.S. have not fared well. Three years ago the Uniwave Di-Wave 100 debuted to dim sales and quietly disappeared a year later. If you wanted to tune into DRM broadcasts, you had to shell out for a Software Defined Radio.

❖ The Newstar DR111

One year ago the China-based Chengdu Newstar Electronics Corporation (CDNSE) introduced its Newstar DR111 digital shortwave radio at the April National Association

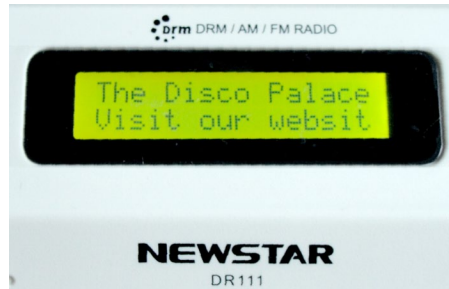

Disco Palace DRM reception demonstrates stereo audio capability.

of Broadcasters (NAB) convention. This year demonstration units for review were circulated by Newstar, one of which I received. The DR111 is deceptively simple looking. With only one small knob and one small button on the front panel, and a two-line LCD display, it looks a little like a stripped-down boom box. But, atop the radio are 17 buttons that actually comprise the rest of the controls you'll need for this radio.

You should expect designs to change with a radio this radically different and the DR111 attempts several new ideas. The first obvious idea is to have two speakers. Most portable shortwave radios don't need them but the DR111 makes use of them when tuning in local FM stereo stations and when tuning in DRM shortwave signals. When I first tuned in Disco Palace (15775 kHz)

I was startled to hear stereo on shortwave. Of course, the speakers are very small, don't deliver much in the way of audio fidelity and they are only six inches apart, center-to-center, so you can forget hearing much stereo separation. Still, it was nonetheless interesting to hear stereo coming out of a portable shortwave radio. Actually, portable is not really the right word. Though it looks as if it should be, it's not portable. There isn't a battery pack in these first units though I expect it will become more of a portable set if it lives long enough to get into full production.



Vatican Radio in DRM via RCI's 9800 kHz relay, flawless reception sounded like a local FM station.

Another departure from any other small shortwave set is the eccentric tuning system. It's a little confusing at first, but once you've figured it out it's not that hard to get around the bands. Primary tuning is done with the small tuning knob on the front which can be made to tune rapidly or slowly through the frequencies. Once you get a frequency you'd like to keep, you can mark it as a preset and return to it when you like. Press the tuning button and it's a volume control, press it again and it's a tuning knob. Functions such as clock settings are done with the top-mounted buttons that are so labeled.

❖ The DR111 in Action

I've had use of the DR111 for part of the spring and all of the summer which is not the optimum time to be testing a new shortwave receiver; atmospheric conditions are high and the solar cycle has been shaky. Still, I was quite impressed with being able to receive DRM broadcasts from RCI's Sackville relay station (while it was still functioning) tuning into Vatican Radio broadcasts that sounded for all the world like a local FM station. This reception was with the 42 inch telescoping whip antenna only and the

DRM111 SPECIFICATIONS

(As provided by the manufacturer)

FM – 87.5 MHz-108 MHz

DRM Tuning (digital)

LW: 150-288 kHz

MW: 522-1720 kHz

SW: 2.3-27 MHz

AM Tuning (analog)

LW: 150-288 kHz

MW: 522-1720 kHz

SW: 2.3-27 MHz

Clock: Real time; Radio Alarm; Buzzer Alarm and Sleep Timer

Audio Out: 8 ohm Mini plug

Features: Stereo speakers and earbuds; 48 memory presets; 16 character 2 line LCD display, adjustable tuning speeds, SD card for firmware updates and to play prerecorded music, external antenna jack, USB slot.

Power: 5 volts DC at 1000 mA

Size: 10.9 (W) x 4.69 (H) x 3.5 (D)

Weight: 29.9 oz.



DR111 RDS FM display shows WCVE-FM Richmond.

radio sitting on the dining room table. Attaching an external antenna at my desk to the DR111, the Disco Palace came through nicely.

One of the advantages of a firmware-driven digital receiver is being able to update the firmware as improvements are made. To do this you'll need an SD card (I found that the card in one of our digital cameras was perfect for the task) and a laptop that can download to such a card (my desktop computer doesn't have an SD slot). Once you've successfully downloaded the data to the SD card, simply slip the card into the handy card slot on the left side of the receiver (with the power off) and power up the radio. It detects the card, reads it and replaces the old firmware with the new version.

During the time I've had the receiver CDNSE made three firmware updates available that improved AM tuning, supported DRM reception logging, improved the volume control,



Top-mounted tuning and function buttons are a little peculiar, but easy to use once you get used to them.

AGC tracking, and much more.

Using the Uniwave Di-Wave 100 two years ago and today using the DR111, I've found that DRM reception on the east coast is spotty. With only a handful of stations in Europe transmitting, only the best band conditions allow DRM signals to travel very far. With the Di-Wave 100 I was able to pick up the DRM signal from as far away as Romania. But, conditions were better that year. With the DR111, I've not been able to hear any European DRM stations though I understand that west coast listeners have been able to receive Radio New Zealand's DRM signal. But, with 9800 kHz now defunct and only occasional broadcasts from Disco Palace, you have to ask, what's the point? DRM appears to be moving backwards.

❖ The Bottom Line

AM and FM reception on the DR111 is about what you'd expect from any small portable radio. While analog shortwave reception was not up to the level of the Kaito 1103, for example, the DR111's big point is DRM reception, but only being able to tune in two DRM stations will make this radio a non-starter in the U.S. at any price. Even if it does make it to full production, I expect it to quietly disappear as did the Di-Wave 100.

DRM is actually doing quite nicely in Europe where it's making digital inroads on not only the shortwave bands but AM and FM bands as well. No such luck here. With FCC-mandated HD-Radio's stranglehold on domestic AM and FM digital broadcasting, there's little interest in DRM for domestic shortwave broadcasting. The reason is simple: money. It's very expensive to convert any transmitter to DRM broadcast standards and U.S. shortwave services are strapped enough for cash to give it much thought.

So, for U.S. audiences it's the old chicken-and-egg deal: How are you going to sell DRM capable radios to an audience that can't receive the signals? Why bother trying to transmit DRM to the U.S. if there aren't enough receivers to make up an audience?

The Newstar DR111 is not FCC approved for sale in the U.S. at this time and there is no word from the company as to whether or not it will even attempt FCC certification. There's no actual manufacturer's suggested retail price, but should they choose one, it will have to be under \$100 to attract the attention of any future U.S. buyers.

Take Charge Power Strips

AMAZING PROTECTION FOR GREAT PRICES!



Order PWR19
Only \$19.95*

*plus \$3.95 USPS shipping in the U.S.



Order PWR20
Only \$24.95*

*plus \$9.95 USPS shipping in the U.S.



Order PWR21
Only \$24.95*

*plus \$9.95 USPS shipping in the U.S.

The Take Charge Power Saver captured Best in Class for the New Product World Award and received Honorable Mention – Best in Class – Housewares from Home Business World at the 2012 National Hardware Show in Las Vegas, NV

GROVE

800-438-8155

828-837-9200 fax: 828-837-2216

order@grove-ent.com

7540 Highway 64 West Brasstown, NC 28902

ORDER NOW!

WWW.GROVE-ENT.COM

Tablerock “Shortwave Daddy” Receiver Kit

By Bob Grove W8JHD

In the olden golden days of radio, experimenters would contrive simple receivers commonly called “breadboard” radios, reflecting the use of broad pieces of wood (often actual breadboards) used to screw down parts and wiring.

The closest thing we have now to breadboards are printed circuits with their miniature components soldered in place. The “Shortwave Daddy” is an excellent example of this latter architecture. It is available both as a kit of parts and as a fully factory-assembled model. A detailed, well-illustrated assembly/instruction manual is included. A case is not.

The receiver is intended to be used with a computer and is powered directly from that computer’s USB port and uses the computer’s sound system. No driver software is required, and the platforms of Windows 7, Vista, and XP as well as many legacy versions will work.

MAC (Apple) versions will work as well with the addition of the free LineIn program available from www.rogueamoeba.com/freebies.

Lacking driver software, there is no automatic recognition of the USB port into which the receiver is plugged. Step-by-step instructions lead the user through the process of choosing the port from the computer sound settings in its operating system.

A BNC connector and a 3.5 mm (1/8-inch) jack (this is not an audio connector) are provided for your choice of antenna plug.

The 1-inch x 3-inch, four line, 20 character LCD panel shows the receive frequency, relative signal strength, signal to noise ratio, FM call letters, and station type if transmitted (rock, classical, etc.).

The circuitry makes use of commonly-utilized chips found in automotive radios that cover the AM and FM bands. Since off-shore-manufactured radios are more likely to have shortwave coverage as well as extended AM and FM band limits, the chips enable this radio to cover 149 kHz – 30 MHz (AM) as well as 64-108 MHz (FM) in order to satisfy the requirements of the foreign automotive market.

In this receiver, AM/FM/shortwave reception is provided by a Silicon Labs SI4735 chip that is, in turn, controlled by a Microchip PIC18F2550 microprocessor. Audio decoding is done by a PCM2906C codec IC.

For readers with boundless technical curiosity, SL’s programming guide for the receiver chip may be downloaded at www.silabs.com/Support%20Documents/TechnicalDocs/AN332.pdf. AGC attack and release rates, front-end AGC control, and many other functions may be massaged by reprogramming. This aftermarket capability will be covered more below.

Receive frequencies may be directly keyboard entered, or auto searched at the touch of a single pushbutton. The scan rate varied from 30-70 steps per second depending on the frequency range. Steps are 1-kHz AM, but larger for the wider-spaced FM channels which are separated by 200 kHz in the U.S.

A row of four separate pushbuttons select AM, AM seek, FM, and FM seek. When the auto tuning seek function has been selected, the radio will rapidly step in search of active channels, stopping on an occupied frequency for listening.

All frequency entries are made in a five-digit format followed by a press of the # key. 15000 kHz (15 MHz) would be entered as 15000; 5000 kHz as 05000; 650 kHz as 00650; and 95.1 MHz as 09510 (no decimal is necessary).

AM selectivity is keypad selectable in seven steps from 1- 6 kHz. But it’s not a simple matter of pressing the corresponding numeric key; it’s encoded just like the frequency entry. For example, a selection 3-kHz bandwidth would be made by pressing 00002. A chart is provided. FM selectivity is not adjustable. Should a functional glitch occur, a convenient reset button is provided to give the circuitry a fresh restart.

❖ The Bottom Line

There is no pretense about this radio; it’s not intended to compete with full radio receivers or SDR black boxes. Its primary goal is to satisfy those who would like to build a receiver that can be custom programmed for various settings.



The Shortwave Daddy is built around a professionally-laid-out PC board utilizing high quality components. All factory pre-drilled holes are “through hole” making soldering a more reliable process. The few connections for surface-mount connections, and the surface-mount parts themselves, are solder-plated for more secure attachment.

The well-written assembly steps, tutorial techniques, and illustrations are reminiscent of the high-quality Heathkit instructions that accompanied that company’s legendary kits.

The compact 7-inch x 4-inch board outline invites housing in a case, although that certainly isn’t necessary for satisfactory operation. Rear-edge connectors for the antenna and USB cord are very sturdily mounted.

The selectivity options certainly do help reduce adjacent-frequency interference on the shortwave bands. Naturally, high frequencies of the audio become attenuated with the tighter bandwidths.

Sensitivity throughout its reception range is excellent. On shortwave the sensitivity was on par with a \$5000 communications receiver.

We noticed some pumping of the audio on strong AM signals, especially at narrow bandwidths. Widening the selectivity minimized this while also increasing the audio in the treble (high frequency) range. This effectively reduces sensitivity by increasing the signal-to-noise ratio (SNR).

As previously mentioned, this is an experimenter’s radio, not a competitive DX machine. The manufacturer is planning to open-source its operating software, enabling computer-savvy technical types to do their own coding. ICs are plug-in, allowing substitutions to preserve original programming in the factory chips.

The resident program on the PIC18LF2550 is written in C language. An on-board, six-pin header allows the user to experiment with his own program using a tool like the Pikit 2 programmer.

We would not recommend the kit as a first assembly project for budding electronic hobbyists, but for skilled enthusiasts with a delicate touch, it awaits your soldering irons. And, if you’re too anxious to build one yourself, the factory-assembled version awaits.

The Shortwave Daddy is available in kit for \$234.99 and the factory assembled and tested model sells for \$289.99. U.S. shipping is \$10.95 from Tablerock Electronics Company, 2520 La Cumbra Circle, Rancho Cordova, CA 95670. Visit their website at shortwavedaddy.com.

Uniden BC125AT Scanner

By Larry Van Horn N5FPW

When you pin down experienced scanner radio hobbyists and ask them to share some of their secrets of success, there are usually one or two items that will top their list. Depending on their listening interest, most will probably tell you that the more scanners you own programmed for specific listening targets, the better chances you will have of hearing what you want to hear.

Instead of cramming everything into one or two radios, spreading them around to several radios programmed with similar frequencies will produce better listening results.

This equipment technique also translates well when the hobbyist wants to scan major field monitoring opportunities such as air shows, automobile races, maritime monitoring near major ports and rivers, etc. These “events” lend themselves well to a more focused and concentrated load out of frequencies directly associated with that particular event.

And that brings me to the focus of this review – the Uniden BC125AT, a handheld, bargain-priced scanner. The BC125AT is Uniden’s latest scanner and is loaded with a lot of great features. It is touted as an “event scanner” with a focus on being used at air shows and racing events. However, this scanner is much more than that. This is a great analog, conventional scanner for VHF-High band, civil and military air bands.

The Bearcat BC125AT is an affordable 500 channel (ten banks of 50) analog scanner with great features. The unit’s frequency coverage is 25-54, 108-174, 225-380 and 400-512 MHz. This unit is intended for general purpose listening to non-trunked public safety, business, railroad, ham, CB, civilian and military aircraft, and other analog communications.

The BC-125AT comes with two NiMH AA batteries, a belt clip and hand strap, a flexible BNC antenna, USB cable and a printed owner’s manual.

❖ Loaded with Higher End Features

Many of the features that are included with this unit, you would only expect to see in a higher priced scanner which makes this unit a great bargain at just \$130 plus shipping.

The Priority Scan with Do Not Disturb function lets you program one channel in each bank (10 in all) and then have the scanner check each channel every two seconds while it scans the banks so you don’t miss transmissions on those channels. Each of these channels can be alpha-tagged.

Do Not Disturb keeps the scanner from interrupting transmissions during receiving. You can also lock out up to 200 search frequencies (100 temporary frequencies and 100 permanent frequencies) in custom search, service search, Close Call search, or quick search modes.

The BC125AT has Uniden’s Close Call® RF Capture Technology that instantly tunes to signals from nearby transmitters. The Priority Scan function scans the channels you have designated as priority channels. The Delay function helps prevent missed replies during 2-way conversations.

There are ten service banks with preset frequencies for police, fire/emergency, amateur radio, marine, railroad, civilian air, military air, CB radio, FRS/GMRS/MURS, and racing banks to make it easy to locate specific types of calls and search any or all of these banks.

You can program a CTCSS or DCS frequency into the BC125AT to monitor systems using a CTCSS or DCS tones. This radio does support NFM (narrow FM) for all the conventional channels that are heading toward federally mandated narrow banding by 2013.

The backlit full frequency LCD display makes for easy night time operation. Operation is from two AA cells providing flexibility in choice of batteries – alkaline for long life and rechargeable (supplied) for economy. The batteries charge while in the scanner. The included NiMH AA batteries may be charged from a USB power source (such as a PC) or the optional MCM-MW858 USB AC adapter via the included USB cable.

❖ Bottom Line

First, let me get the negatives and perceived negatives out of the way. I have heard a lot of complaints among some hobbyist on Internet newsgroups about the lack of coverage from 380-400 MHz (the new Department of Defense land mobile radio sub-band).

As the author of the yearly *MT Air Show Guide* I’m sensitive to issues like this. As I

pointed out in the September 2012 *MT Milcom* column, there are approximately 70 aeronautical frequencies left that we have identified in this frequency range. This includes 384.550 MHz which is used by several military flight demo groups. So does this diminish my enthusiasm of this unit as a possible air show scanner? Not one bit and it will be listed in the next *MT* air show equipment guide.

I really only have one chief complaint regarding this unit. I really would like to have seen some sort of attenuator function on this scanner. In high RF environments such as air shows or automobile races this can be an important feature to handle strong signal overload.

I like the large LCD. You can see your alpha tag, frequency/channel number, mode, tone, and signal strength on the screen at the same time. I do wish I could dim that display sometimes to save on batteries.

The scanner is very easy to program and operate. Audio is very good and the speaker has a clear tone and is loud enough in the car to be heard over road noise.

So the bottom line is this: If you need a great “event based” style scanner at a great price, I strongly recommend the BC125AT from Uniden. This scanner is available from Grove Enterprises (SCN58) for \$129.95 plus shipping.

BC125AT SCANNER SPECIFICATIONS

- 500 Alpha tagged channels in 10 banks
- VHF Low, VHF High, UHF, civilian and military air bands
- Narrowband steps
- Close Call® RF capture (instantly tunes to signals from nearby transmitters)
- Close Call® Do not disturb mode (prevents close call checks during a transmission)
- Service search banks
- Squelch: CTCSS and DCS
- Priority search with do not disturb
- Backlit LCD display
- Weather alert (no NOAA SAME alert)
- PC Programming port (charge batteries from PC via USB)
- Signal strength indicator: Bargraph

Detailed Frequency Coverage (MHz)	
25.000 - 30.000	Amateur band 10 meters
30.000 - 50.000	VHF Low band
50.000 - 54.000	Amateur band 6 meters
108.000 - 137.000	Civilian aircraft band
137.000 - 144.000	U.S. Military Air/LMR
144.000 - 148.000	Amateur band 2 meters
148.000 - 150.800	U.S. Military Air/LMR
150.800 - 174.000	VHF High band
225.000 - 380.000	Military aircraft band
400.000 - 420.000	Federal government
420.000 - 450.000	Amateur band 70 cm
450.000 - 470.000	UHF Band
470.000 - 512.000	UHF “T” band



What's NEW

Tell them you saw it in Monitoring Times

Larry Van Horn, New Products Editor

Domestic Broadcast Survey 2012

The 55 year old Danish Shortwave Club International (DSWCI), which has members in 33 countries, has issued the 14th edition of their annual *Domestic Broadcasting Survey* (DBS) which is divided into three parts:

- Part 1 – The Tropical Bands Survey covers all active shortwave broadcasting stations transmitting in the 2300 to 5700 kHz range including clandestines.
- Part 2 – Domestic stations on international shortwave bands above 5700 kHz broadcasting to a domestic audience.
- Part 3 – Deleted frequencies between 2 and 30 MHz which have not been reported heard during the past five years, but may reappear. While Part 3 is only published in the email version, buyers of the printed version can get a copy from the Editor upon request.

This new edition of the survey is based upon many official sources and club DX-bulletins. Shortwave broadcast A11 schedules are included in this publication when available. One of the useful features for easy station identification is the inclusion of parallel frequencies and reference to station identification slogans.



All buyers of DBS-14 will get a username and password to the monthly updates on the tropical bands published as "Tropical Bands Monitor" on the DSWCI website at www.dswci.org/tbm.

The 23 pages A-4 size DBS-14 is available by email as an Adobe Acrobat PDF format (about 505 kb in size). There is a limited number of the printed version of this publication which is 20 pages and does not include the aforementioned Part 3.

The DSWCI DBS-14 is sold by the club treasurer via the following address – DSWCI, c/o Bent Nielsen, Egekrogen 14, DK 3500 Vaerloese Denmark.

Prices for the email and print version are:

Email edition: DKK 35,00; US \$7.00; EUR 5,00; GBP 4,00; SEK 45,00 or three IRCs.
Print edition: DKK 70,00; US \$13.00; EUR 10,00; GBP 8,00; SEK 90,00 or five IRCs.

Payment by cash notes are accepted whereas checks and postal money orders are not. If you want to pay via PayPal, you may do so only in U.S. currency and this only for persons living outside the European Union (EU). You will have to contact Andreas Schmid below before you send payment.

If you have the Euro as your national currency, you should send payment to the club representative in Germany – Andreas Schmid, Lerchenweg 4, D-97717 Euerdorf, Germany. Email: schmidandy@aol.com

Icom Loan Program with Boy Scouts

Icom America has extended its recent Boy Scouts of America (BSA) partnership by providing up to ten complete amateur stations for use by local Scouts councils. The amateur radio loan program comprises two loans: a development loan station and an event loan station. Interested parties may download program information and a loan application on the BSA's Jamboree-on-the-Air (JOTA) webpage www.scouting.org/jota/station-loan.aspx. This program began in 2012 and extends through 2015.

Scout councils awarded a development loan station can develop long-term installation for their Radio Scouting programs. The development loan award is expected to last no longer than 12 months. Local councils applying for an event loan station may use their stations for special events including but not limited to: the American Radio Relay League (ARRL) Field Day and BSA workshops.

"These stations can be used to support Radio merit badges, JOTA, or other council events to introduce Scouts to the fun and technology of amateur radio while communicating across the country and around the world," says National Radio Scouting Committee Chairman Jim Wilson, K5ND.

Icom's amateur radio station kits consist of the manufacturer's IC-7200, an entry-level HF transceiver with advanced digital features. Other loan station components include Icom's AT-180 antenna tuner, PS-126 power supply, SM-30 desk microphone, SP-5 external speaker, AH-710 folded dipole antenna, and suitable connecting cables. According to Icom America's Amateur Division Manager Ray Novak N9JA, "Ten complete station kits have been assembled and are ready for delivery."

In May 2012, Icom America became the official amateur radio transceiver and repeater supplier for the 2013 National Scout Jamboree. The company has been a proud supporter of BSA since 1981. For information on Icom America's amateur radio product line, visit www.icomamerica.com/amateur.

DX Engineering's New Coax

DX Engineering has introduced a new premium coaxial cable for the radio hobby marketplace. Specially manufactured for



DX Engineering, the DXE-400MAX premium 50 ohm coaxial cable is protected with a rugged Type III-A UV-resistant polyethylene jacket. This makes it ideal for any indoor or outdoor application and particularly suited for direct burial.

With its AWG #10 stranded bare copper center conductor, DXE-400MAX cable is more flexible than standard LMR400. It is specially suited for high-power amateur stations, and provides a lower loss solution for long cable runs at any power level. The DXE-400MAX features a gas injected foam polyethylene dielectric covered with two layers of shielding: bonded foil and tinned copper braid.

An introductory price of \$0.82 per foot is currently available. Ready-made coaxial assemblies with Silver/Teflon PL-259s are priced from \$11.88 to \$195.88. For more information or to order, visit www.dxengineering.com.

Utility DXer's QSL Address Handbook

Whether collecting verification cards ("veries" or QSLs) from utility (communications) stations around the globe is a dying art is debatable, but many shortwave listeners (SWLs) still do it.

Ship-to-shore, international aeronautical, military, Coast Guard, government stations, emergency and law enforcement links, weather stations and more are common listening targets for devoted shortwave hobbyists.

But finding the mailing addresses for these elusive DX (distant "utes") can be frustrating, even online. To help, veteran SWL Steve Handler has just released his *Utility DXer's QSL Address Handbook*, a 56 page soft-cover book listing postal and email addresses of many utility stations around the globe.

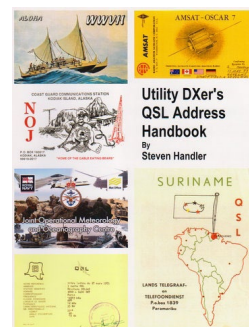

Where applicable, Handler also includes comments such as the type of QSL the station issues, the preferred method of contact, information on station officials, verification signers and more.

The 8-1/2 by 11-inch handbook also contains dozens of images of QSLs from the author's personal collection, many in full color.

Utility DXer's QSL Address Handbook sells for \$14.95 plus shipping from Steven Handler, PO Box 11, Lincolnshire, IL 60069-0011. For more information, email the author at shortwave-report@yahoo.com.

MFJ IntelliTuners Released

MFJ Enterprises Inc., in Starkville, Mississippi, has released two new remote IntelliTuners for use in the HF radio spectrum. These new remote 993BRT and 994BRT IntelliTuners are mounted in a durable hard plastic case that measure just 9.25 inches by 3 inches by 14.25 inches. Frequency coverage is 1.8 to 30 MHz. Both models have heavy duty 16 Amp / 1000 Volt relays and a highly efficient L-network. They also include the MFJ-4117 BiasTee Power Injector to send DC/RF down the coax to the shack.

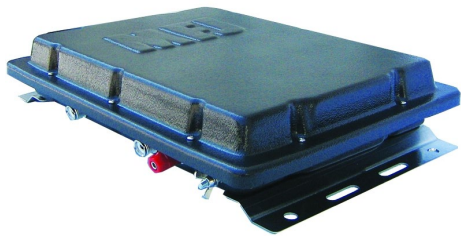

The MFJ-994BRT can handle up to 600 Watts SSB/CW and is a perfect match for Ameritron's solid state ALS-600/S solid state amplifier and the popular tube-type AL-811/H amplifier. The tuner can match 12- to 800-Ohm antennas.

A lower power version, the MFJ-993BRT handles up to 300 Watts SSB/CW power levels and matches 6- to 1600-Ohm antennas. The MFJ-993BRT lets you tune any antenna automatically balanced or unbalanced.

MFJ's exclusive Adaptive Search and InstantRecall algorithms provide the operator with an ultra-fast automatic tuning capability with over 10,000 Virtual Antenna memories available.

You can get more information on these two tuners or any item of MFJ's large catalog on their website www.mfjenterprises.com or from any of their over 250 dealers worldwide.

You can contact the company at 1-800-647-1800 / 662-323-5869 or via snail mail at MFJ Enterprises, Inc., P.O. Box 494, Mississippi State, MS 39762.

RigExpert AA-1000

RigExpert Ukraine has released a new antenna analysis tool, the AA-1000, a powerful antenna analyzer designed for testing, checking, tuning or repairing antennas and antenna feedlines. Easy to use measurement modes, as well as additional features, such as connection to a personal computer, make RigExpert AA-1000 an attractive tool for both the professional and the radio hobbyists.

The following tasks are easily accomplished by using this analyzer:



- Rapid check-out of an antenna
- Tuning an antenna to resonance
- Antenna SWR and impedance measurement and comparison before and after specific event (rain, hurricane, etc.)
- Making coaxial lines or measuring their parameters
- Cable testing and fault location
- Measuring capacitance or inductance of reactive loads

You can get more details about this new product and a list of dealers worldwide on the RigExpert Ukraine website at www.rigexpert.com. U.S. and Canadian readers can purchase this product from Yuri Onipko N2WCQ, P.O. Box 1403, Buffalo, NY 14225-8403, U.S.A. Telephone 716 240 4597, email: usa@rigexpert.net, and website: www.rigexpert.net.

70 cm ATV Transmitter from KH6HTV Video

Jim Andrews, the owner of KH6HTV Video, now offers a complete line of 70 cm digital and analog ham TV transmitters. The digital transmitters generate high-definition, 720p or 1080i, QAM-64 signals. The analog transmitters generate spectrally clean, standard definition, 480i, NTSC, Vestigial Upper Sideband (VUSB). Reception is very easy as these are exactly the modulation formats used on cable TV (CATV). A conventional, home, analog/digital, TV receiver will also tune these signals.

A complete line is offered with different models intended for portable pack-set, mobile, base and repeater applications. Available output powers range from 1 to 25 watts for analog TV and 1 to 5 watts for digital TV.

For more information, specifications, pricing and application notes, visit www.kh6htv.com.



New Array Solutions Coax Surge Arrestor

Array Solutions has a new series of coaxial lightning arrestors, the AS-303, designed to protect radio equipment attached to antennas. They will protect from sand, rain and snow static buildup on antennas and feed lines which can damage sensitive radio equipment. They also will protect against damage from nearby and overhead lightning strikes and can mitigate damage to radios or other equipment from occurring inside buildings, enclosures, and homes.

Based on the design by Industrial Communications Engineers' (ICE) 300 Series coaxial arrestors, these arrestors have improved performance, packaging, and mounting hardware. The



arrestors are DC blocked and include static and DC discharge capability just like the famous ICE arrestors.

They also include rated Gas Discharge Tubes (GDT) which can be replaced with simple tools. The static bleed inductor inside the arrestor not only helps to keep the tube from firing, extending the life of the GDT, it eliminates cable discharge noise from the sensitive receiver which can lower the noise level.

The enclosures are small machined aluminum blocks which have a convenient removable bracket to screw the device to a plate. They have also developed a mounting bracket system which can be purchased as an accessory to mount directly to ground rods, or plates inside enclosures, or a wall plate located at a coaxial cable entrance.

Power rating is 3 kW continuous with antenna systems having a 2:1 SWR and 5 kW with a 1:2:1 SWR. Frequency range is 1- to 70-MHz with rated insertion loss of 0.2 db and SWR less than 1:05:1.

Price for the AS-303U (UHF connectors) is \$58; AS-303N (N connectors) \$65; AS-300SB bracket \$22

For more information, or to order, visit www.arrayolutions.com.

You can also contact the company via mail at Array Solutions, 2611 North Beltline Road, Suite 109, Sunnyvale, Texas, USA 75182 or telephone 214-954-7140.

Books and equipment for announcement or review should be sent to What's New, c/o Monitoring Times, 7540 Highway 64 West, Brasstown, NC 28902. Press releases may be faxed to 828-837-2216 or emailed to Larry Van Horn, larryvanhorn@monitoringtimes.com.

When ordering or inquiring about the products mentioned in this column, be sure to tell them that you saw it in the pages of *Monitoring Times* magazine.

LF Engineering Co.

Manufacturers of Low Frequency Equipment for LF/VLF Communications, Natural Radio Research, AM Broadcast, Marine and Shortwave Radio.

Low Frequency design work since 1982

Active E-Field Antennas • Loop Antennas



860-526-4759 • www.lfengineering.com



to the editors

editor@monitoringtimes.com

This column is open to your considered comments. Opinions expressed here are not necessarily those of Monitoring Times. Your letters may be edited or shortened for clarity and length. Please mail to Letters to the Editor, 7540 Hwy 64 West, Brasstown, NC 28902 or email editor@monitoringtimes.com
Happy monitoring!
Ken Reitz, Editor

Note from the Publisher

As *Monitoring Times* continues to grow, staff changes are inevitable. For the last three decades the magazine has been carefully guided by our original managing editor, Rachel Baughn KE4OPD, who has decided to retire in order to spend more time with her family and travel. Over the last three years Rachel has been gradually transferring editorial management responsibilities to our new managing editor Ken Reitz KS4ZR. Rachel will continue to assist Ken in proofreading columns and articles.

As most *MT* readers know Ken has been a columnist and features writer with the magazine since 1988 and now moves up from his former position as features editor. Ken has also done extensive work as a freelance writer-editor for several nationally distributed magazines. He earlier spent five years in commercial and public radio and this year published three Kindle e-books based on his *MT* work. We welcome him to his new post and look forward to this enlargement of his well-proven skills in writing and editing for *MT*.

— Bob Grove, Publisher

Print Reader Switches to MTXpress

Thanks for the digital link to *Monitoring Times* for September 2012. You have really changed my mind about how I receive *Monitoring Times*. I download it to my iPad and I just love it. I can take it anywhere and open up right where I left off. I didn't even open my August paper issue. I never thought I'd say it, but this is just fantastic!! Please don't bother sending the printed version anymore. If there's a saving to you, please just keep it. When it's time to renew, I'll continue the digital version. Keep up the great work. — Gary Morgan

Thanks for the kind words, Gary! We pro-rated the remaining issues on his print subscription and added them to his MTXpress subscription. If you're a new iPad or other portable tablet computer user, you can find out what's got Gary so excited by downloading a free back issue of *MT*, purchase a single back issue for just \$1.99, or subscribe in any number of ways by going here: www.grove-ent.com/page81.html A one-year subscription to MTXpress is only \$19.95. MTXpress can also be read on any laptop or desktop computer where all the article-embedded links are active. — Editor

U.K. Analog-to-Digital Blues

I enjoy reading your magazine, but I feel frustrated that so much digital data is encrypted and there are no HF press services. Could *MT* address this point? Worse, all the police and other utilities have done the same. International broadcasters have been watered down compared to ten years ago, and thus I



don't listen to HF that much anymore. Could *MT* discuss these points? I can't even receive TV anymore in the U.K., the sound is sent digitally. I use a Bearcat XLT9000 but there isn't much to monitor here in London, even on two meters. How do others feel about this situation? — Ronald Edberg, London, England

Of course, veteran listeners to any part of the spectrum bemoan the lack of reception of many of the old targets. Some have faded away, but the spectrum is still a valuable asset and stalwart listeners are rewarded by many catches.

The economy, concerns about privacy as well as security, replacement of antiquated equipment with newer technologies, the availability of satellites and fiber optic cable, and better signal delivery techniques all play a role in the diminution of received signals by conventional means.

Some countries are way ahead of the U.S. in digital communications; others are far behind. In this country, the Federal Communications Commission (FCC) oversees an ever-growing population of licensees, requiring bandwidth-reduction techniques to accommodate the increasing numbers. Receiver and scanner manufacturers respond by bringing out new models for the listener.

*While some may decry the loss of some of our favorite listening targets of the past, others simply move their interest to different transmissions. At *MT* our mission is to keep up with the times by providing our readers with news of the latest developments in radio technology, what equipment they may need as well as when and where to listen. — Bob Grove, Publisher*

Still Listening after all these Years

Going through old issues, I realized I've been along for the ride for over 25 years now. The attached photo (above) shows my 1987 *MT*s to the left of the Grundig SAT800 and my current 2012 issues to the right of the radio. Above that my "big boy toys," as my wife calls them. God bless her tolerance with me and the hobby! Yep, I have all the copies since 1987 packed away in different closets around the house!

Retired in Florida for 10 years now; longwires and Florida lightning adds to the excitement of the hobby down here! No direct hits yet, but three have been real close and wiped out a couple of radios, phones, garage door control circuit, sprinkler system controls to name a few. I did have one crackling arc flash across my radio room while I was in there watching TV! More grounding rods were added outside! A big thanks to you and your staff and for all the great input you provide us on all facets of the hobby. — Ron Cesarek, Ocala, Florida

Wow, that's a nice monitoring post! And, I know what you mean about the lightning; Judy and I live on a mountain top! — Bob Grove, Publisher

Kent Britain's 4 Element 2 Meter Yagi Design (MT January 2012)

Just finished building your 4 element 2 meter Yagi and it works great; consistent 100+ miles simplex with 5-50 watts (though much of the path from San Diego to the Los Angeles basin is often over water). I built the antenna

pretty much according to your recipe except I scaled it from 144.2 to 146 MHz; used 3/32 copper coated steel brazing rod, and instead of hollow copper connectors, I wrapped some solid wire around the brazing rod and used this as both the connector and element extender. The whole thing went together quickly and cost way under five bucks. Thank you for designing and publishing your antenna designs.
 – Al N6ZI

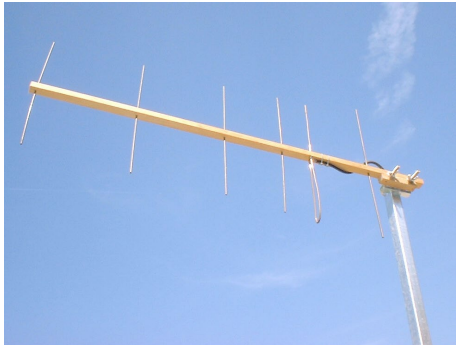

(Photo courtesy Ken Britain WA5VJB)

Hi Alan! Glad it worked out for you. 146 MHz versions have been published in CQ, but it has been a while. Perhaps it's time to revisit that band. At the Central States VHF Society conference we had a VHF101 course. I have made up a batch of kits for the students to build up. One boom and how you cut the elements also makes it a SSB, AMSAT, FM model for the 70 cm band. Good DXing – Kent Britain WA5VJB

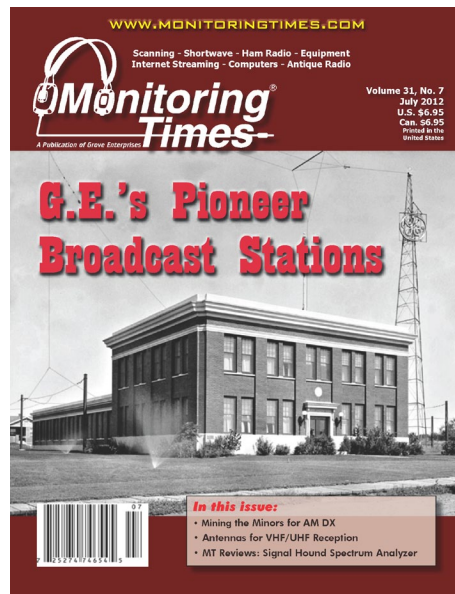

Pioneer Broadcast Building in Trouble

I am contacting you folks because of the cover on your July issue. I am for all intents and purposes a retired engineer, but for reasons of economics I work as a security guard full time. My post is the G.E. site in Oakland at 5441 International Blvd., where I work the midnight to 8 a.m. shift, Fridays through Tuesdays. From Monday, August 13 through August 31 is the beginning of an environmen-

tal review process for the property. G.E. wants to demolish everything on the site including building #1 [the same architecture as the building pictured on the July cover of MT] which is already classified as A1+ historic. G.E. has been pushing for the demolition for two years! Perhaps you could muster some support for this historic building and help turn it into a museum for radio of the bygone eras, and a boon for G.E. corporate itself.
 – Richard Neveln, Oakland, California

Thanks, Richard, for bringing this to the attention of our readers. The building in question is in Oakland, California and nearly identical to the one pictured on the July cover of MT, which is in Denver, Colorado. Unfortunately, the time line of the environmental hearings and our publication schedule makes this announcement mute. Still, I hope you will continue to update us on this issue and that others in the Oakland area will do what they can to help preserve this historic building. – Editor

Correction:

On page 8 of the August cover story, "WX4NHC Hurricane Watch," Hurricane Andrew hit the Miami area 20 years ago, not 30 as stated. On page 10, WX4NHC co-director John McHugh's current call sign is K4AG not K4HE as stated. We regret the errors.

AFFORDABLE POWER AND SPEED! Uniden BC-125AT



NEW! Uniden BC125AT hand-held, bargain-priced scanner! Intended for general purpose listening to public safety, business, railroad, ham, CB, civilian and military aircraft, and other analog communications. This new scanner is feature packed with the following -- and more!

- Frequency coverage: 25-54, 108-174, 225-380, and 400-512 MHz.
- Memory: 500 channels in 10 banks
- Close Call: RF capture and frequency readout of nearby signals
- Squelch: CTCSS and DCS
- Service banks: Factory-preloaded with 10 separate police, fire/ emergency, ham, marine, railroad, civilian air, military air, CB, RFS/GMRS/ MURS, and racing frequency for quick search.
- Signal strength indicator: Bargraph
- Antenna: BNC base rubber duckie

Supplied Accessories: 2 NiMH AA batteries, belt clip, flexible BNC antenna, USB cable and Owner's Manual.

Order SCN58
 Only \$129.95*

*plus \$19.95 UPS Ground shipping in the U.S.



800-438-8155

828-837-9200 fax: 828-837-2216

order@grove-ent.com

7540 Highway 64 West Brasstown, NC 28902

ORDER NOW!

WWW.GROVE-ENT.COM

INDEX OF ADVERTISERS

Antique Wireless 63
 AOR..... 3
 ARRL..... CVR3
 Kevin Carey (Longwave)..... 76
 C Crane..... 31
 Computer Aided Technology..... 15
 DZ Kit..... 76
 GroveCVR2, 18, 19, 21, 59, 69, 75
 LF Engineering 73
 M2..... 65
 MT Express9, CVR4
 NASB..... 7
 Profiles in Radio 76
 Stealth 76
 TEAK Publishing 61
 Universal Radio 55, 76
 W5YI 5
 WiNRADiO 1

Reach new customers with your advertising message in *Monitoring Times*! Contact Judy Grove at 1-800-438-8155 or email judy@grove-ent.com

Stock Exchange

For information on Stock Exchange or commercial advertising, contact Judy Grove at 1-800-438-8155 or judy@grove-ent.com

Line Ads \$1 per word

*Thank you for the latest copy of Monitoring Times August 2012. I continue to be very impressed with clarity of the electronic copy downloaded. The text size, the layout, colours etc are all outstanding – a first class job.
 To all those responsible, WELL DONE!*

Regards, Barry, UK

Subscribe to MT for as little as \$17.95 (U.S. Second Class Mail)

7540 Hwy. 64 W.; Brasstown, NC 28902
 1-800-438-8155 US and Can.; 828-837-9200; Fax 828- 837-2216
 e-mail order@grove-ent.com

	6 months	One Year	Two Years	Three Years
Electronic Subscription	<input type="checkbox"/> \$17.95	<input type="checkbox"/> \$19.95	<input type="checkbox"/> \$38.90	<input type="checkbox"/> \$57.85
US Second Class Mail	<input type="checkbox"/> \$17.95	<input type="checkbox"/> \$32.95	<input type="checkbox"/> \$59.95	<input type="checkbox"/> \$89.95
US 1st Class Mail	<input type="checkbox"/> \$32.95	<input type="checkbox"/> \$59.95	<input type="checkbox"/> \$119.00	<input type="checkbox"/> \$179.95
Canada Surface*	<input type="checkbox"/> \$22.95*	<input type="checkbox"/> \$42.95*	<input type="checkbox"/> \$79.95*	<input type="checkbox"/> \$119.95*
Canada Air*	<input type="checkbox"/> \$35.95*	<input type="checkbox"/> \$69.95*	<input type="checkbox"/> \$125.95*	<input type="checkbox"/> \$189.95*
Foreign International*	<input type="checkbox"/> \$30.95*	<input type="checkbox"/> \$58.95*	<input type="checkbox"/> \$119.95*	<input type="checkbox"/> \$179.95*
Foreign Air*	<input type="checkbox"/> \$62.95*	<input type="checkbox"/> \$119.95*	<input type="checkbox"/> \$229.95*	<input type="checkbox"/> \$349.95*

If you order MT Print Edition AND MTXpress Electronic together, MTXpress is only \$11 per year!

* All payments must be in US funds drawn on a US bank.

MasterCard, Visa, Discover Cards and Paypal accepted!



www.dxtreme.com -- Log DXtremely with DXtreme Software!

Columnist Blogs and Web Sites

These blogs and web pages were created by some of our columnists to better serve their readers. While we highly recommend these resources, they are not official instruments of *Monitoring Times*.

AMERICAN BANDSCAN
<http://americanbandscan.blogspot.com/> - by Doug Smith

ANTENNA TOPICS
www.wa5vjb.com - by Kent Britain

BELOW 500KHZ
<http://below500khz.blogspot.com/> - by Kevin Carey

FED FILES
<http://mt-fedfiles.blogspot.com/> - by Chris Parris

LARRY'S MONITORING POST
<http://monitor-post.blogspot.com/> - by Larry Van Horn

MILCOM
<http://mt-milcom.blogspot.com/> - by Larry Van Horn

SCANNING REPORT
<http://www.signalharbor.com/> - by Dan Veeneman

SHORTWAVE
<http://mt-shortwave.blogspot.com/> - by Gayle Van Horn

UTILITY WORLD
<http://mt-utility.blogspot.com/> - by Hugh Stegman
www.ominous-valve.com/uteworld.html

Your ad could be HERE for ONLY \$50!

No unintended exhilaration here!

Build the Sienna HF Transceiver Kit
 True Kit – Soldering Required

www.DZKit.com
 4321 W. Eisenhower Blvd. • Loveland, CO 80537
 1-877-HAM-SHACK

Profiles in Amateur Radio by Ken Reitz, KS4ZR

PROFILES IN AMATEUR RADIO
 By Ken Reitz KS4ZR

A Kindle e-Book, only \$2.99 on Amazon.com.
 Search for book number: B0071OT8CO

Discover Longwave! BeaconFinder II Directory

- 100's of beacons
- 75+ pages, 3-hole punched
- Covers 0-530 kHz spectrum
- \$13.95 postpaid

Sounds of Longwave

- Hear Natural Radio, Milcom, WWVB, beacons, Euro-BC, Lowfers, more!
- \$13.95 postpaid (specify CD or cassette)

Kevin Carey
 Box 56, W. Bloomfield, NY 14585

STEALTH Amateur Radio Complete Guide ANYWHERE!

Complete Guide

- Apartments
- Condos
- CC&R Neighborhoods
- Operate from...

stealthamateur.com

HUGE 100 PAGE CATALOG

- Shortwave & Ham Gear
- Scanners & RTTY/FAX
- Antennas & Accessories
- Radio Books & CDs.

Send \$1 to

Universal Radio
 6830 Americana Pkwy.
 Reynoldsburg, OH 43068
 Tel. 800 431-3939
www.universal-radio.com

Don't Just Listen...Talk Too!

Communicate with People Around the World or Around the Corner

Join ARRL and Discover the Excitement of Ham Radio

The Amateur Radio Service offers a unique mix of public service, technology and experimenting with electronics – all with an emphasis on fun. Some hams use their skills to provide communications during emergencies and disasters when all else fails. Others enjoy talking to people across the country and around the globe, participating in local contests and building experiments. Whatever YOUR interest, ARRL – the national association for Amateur Radio – has all the resources you need to **get started, get involved and get on the air.**

ARRL members have direct access to all the top experts in the Amateur Radio Service. Members enjoy *QST* magazine – ARRL's official journal and the most widely read ham radio publication in the country, free e-newsletters, problem-solving technical advice, access to online product reviews, and much more!

Special Offer! Free Book for Readers of *Monitoring Times*

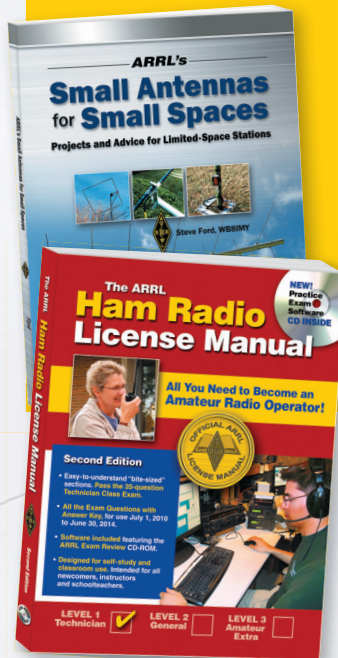

Join ARRL today and get **ARRL's Small Antennas for Small Spaces** book FREE. You'll find ideas and projects that will get you on the air regardless of where you live!

Don't have your Amateur Radio license yet?

ARRL can help you with that, too! Join ARRL and get a FREE copy of **The ARRL Ham Radio License Manual** (book with practice exam software). Pass the 35-question license test.

Go to www.arrl.org/join/MT or call 1-888-277-5289 to take advantage of these special offers.



Learn more about Amateur Radio

Talk, don't just listen. Learn how YOU can become a licensed Amateur Radio operator and get on the air! Discover the benefits of ARRL membership and more by visiting www.arrl.org/MT.

**Join Today! Online www.arrl.org/join/MT
or Call Toll-Free 1-888-277-5289**



ARRL The national association for
AMATEUR RADIO®
www.arrl.org

